

havit

Hochdruckflansche

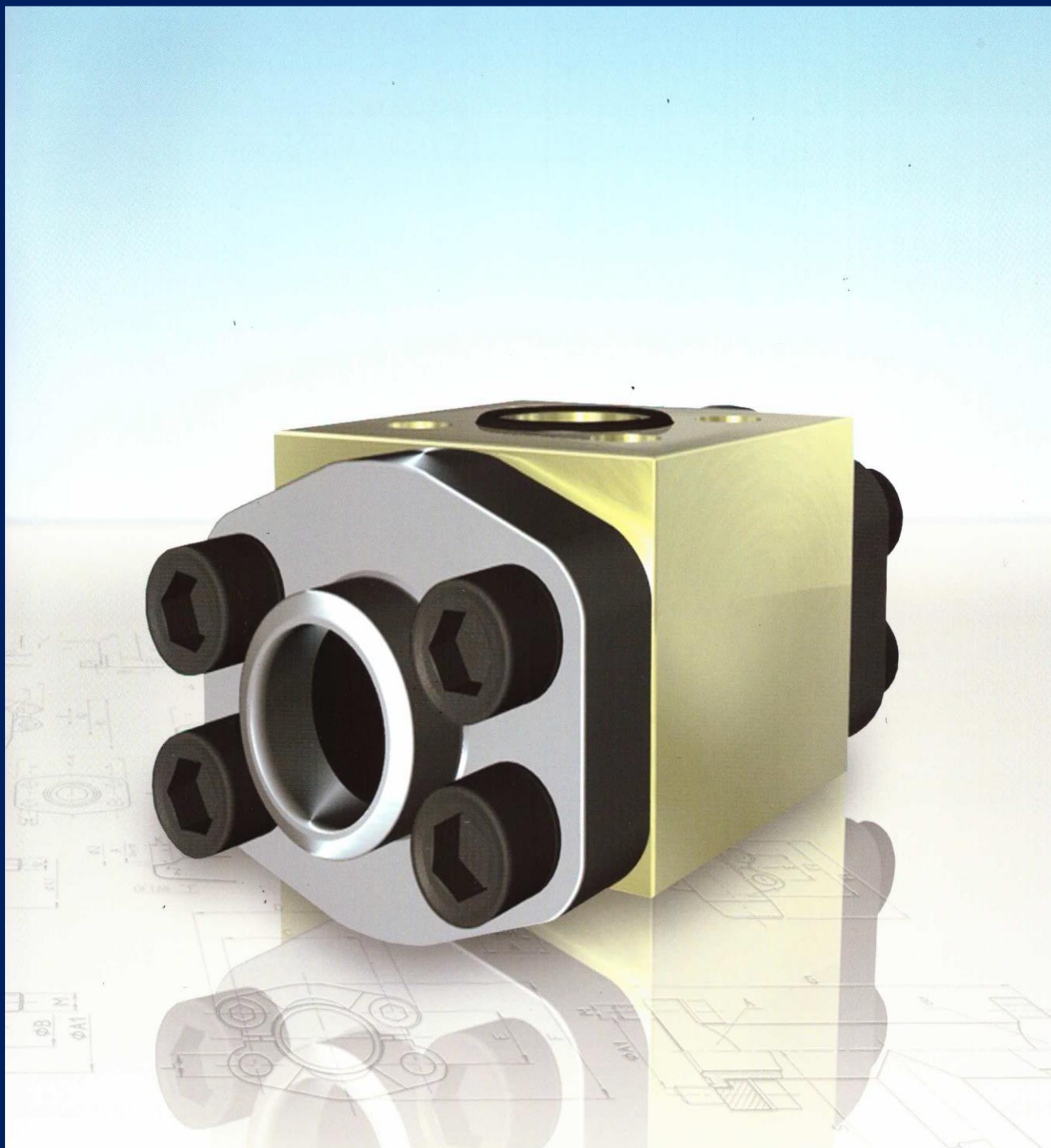

Busse
Hydraulik GmbH

Ausgabe/Edition: 05/2019





Flanschverbindungen ISO 6162 / SAE J518
Flange connections ISO 6162 / SAE J518

Seite
Page

SAE-Flanschhälften / Vollflansche













SAE-split flange halves / SAE-flange clamp











Seite
Page

	SAE-Flanschhälften FH-... SAE-split flange halves	1
	SAE-Vollflansch VF-... SAE-flange clamp	2
	SAE-Flanschhälfte – flach HF-... SAE-split flange – flat	3
	SAE-Vollflansch – flach VFH-... SAE-flange clamp – flat	4
	SAE-Vollflansch mit metrischen Gewinden VFG-... SAE-flange clamp metric tapped	5

SAE-Anschweißflansche







SAE-butt weld flange



































	SAE-Anschweißbund SFS-... SAE-flange head	6/7
	SAE-Anschweißdoppelflansch DSFS-... SAE-welding head-coupling	8/9
	SAE-Flanschbund FT-... SAE-flange head	10
	SAE-Anschweißflansch – zöllig AFS-...ST SAE-butt weld flange – inches	11
	SAE-Anschweiß-Gegenflansch – zöllig GFS-...ST SAE-butt weld flange companion – inches	12
	SAE-Anschweißflansch – Schedule 10 AFS-...ST10 SAE-butt weld flange – schedule 10	13
	SAE-Anschweiß-Gegenflansch – Schedule 10 GFS-...ST10 SAE-butt weld flange companion – schedule 10	14
	SAE-Anschweißflansch – Schedule 40 AFS-...ST40 SAE-butt weld flange – schedule 40	15
	SAE-Anschweiß-Gegenflansch – Schedule 40 GFS-...ST40 SAE-butt weld flange companion – schedule 40	16
	SAE-Anschweißflansch – Schedule 80 AFS-...ST80 SAE-butt weld flange – schedule 80	17
	SAE-Anschweiß-Gegenflansch – Schedule 80 GFS-...ST80 SAE-butt weld flange companion – schedule 80	18
	SAE-Anschweißflansch – Schedule 160 AFS-...ST160 SAE-butt weld flange – schedule 160	19
	SAE-Anschweiß-Gegenflansch – Schedule 160 GFS-...ST160 SAE-butt weld flange companion – schedule 160	20

	SAE-Anschweißflansch – Schedule XX ... AFS-...ST-XX SAE-butt weld flange – schedule XX	21
	SAE-Anschweiß-Gegenflansch – Schedule XX GFS-...ST-XX SAE-butt weld flange companion – schedule XX	22
	SAE-Anschweißflansch – metrisch ND 40 AFS-...STRE SAE-butt weld flange – metric ND 40	23
	SAE-Anschweiß-Gegenflansch – metrisch ND 40 GFS-...STRE SAE-butt weld flange companion – metric ND 40	24/ 25
	SAE-Anschweißflansch – metrisch AFS-...SRE SAE-butt weld flange – metric pipes	26/ 27
	SAE-Anschweiß-Gegenflansch – metrisch GFS-...SRE SAE-butt weld flange – metric pipes – companion	28
	SAE-Anschweiß-Flanschverbinder DFS-...ST SAE-butt weld flange-coupling	29
	SAE-90° Anschweißflansch – zöllig AFS-.../90ST SAE-90° butt weld flange – inches	30/ 31
	SAE-90° Anschweißflansch für metrische Rohre AFS-.../90SRE SAE-90° butt weld flange for metric pipes	32/ 33
	SAE-90° Anschweißflansch-Adapter für metrische Rohre WFS-... SAE-90° butt weld flange-adaptor for metric pipes	34
	SAE-45° Anschweißflansch-Adapter für metrische Rohre WFS-... SAE-45° butt weld flange-adaptor for metric pipes	35



SAE-Einschweißflansche

SAE-socket weld flange



	SAE-Einschweißflansch AFS-...S SAE-socket weld flange	36/ 37
	SAE-Einschweiß-Gegenflansch GFS-...S SAE-socket weld flange companion	38/ 39
	SAE-Einschweißflanschverbinder DFS-...S SAE-socket weld flange-coupling	40/ 41
	SAE-Einschweißflansch ND 40 AFC-...S SAE-socket weld flange 500 PSI	42
	SAE-Einschweiß-Gegenflansch ND 40 GFC-...S SAE-socket weld flange companion 500 PSI	43
	SAE-Einschweißflanschverbinder ND 40 DFC-...S SAE-socket weld flange-coupling 500 PSI	44

		Seite Page			Seite Page
	SAE-Einschweiß-Adapter SAE-socket weld adapter	SWA -.... 45		SAE-45° Flansch-Adapter 24° DIN 3901 SAE-45° flange-adapter DIN 3901	WFG -...-45- L/S 70
	SAE-90° Einschweißflansch SAE- 90° socket weld flange	AFS-.../90S 46		SAE-Außengewinde Adapter JIC 37° SAE-adapter JIC 37°	SFCE-... JIC 71
	SAE-90° Einschweiß-Gegenflansch SAE- 90° socket weld flange companion	GFS-.../90S 47		SAE-Außengewindeflansch JIC 37° SAE- threaded flange JIC 37°	AFG-... JIC 72/ 73
SAE-Einschraubflansche SAE-pipe threaded flange				SAE-90° Flansch Adapter JIC 37° – geschmiedet SAE-90° flange adapter JIC 37° – forged	WFG -... JIC 74/ 75
	SAE-Einschraubflansch BSPP-Gewinde SAE-pipe threaded flange BSPP	AFS-...G 48/ 49		SAE-45° Flansch Adapter JIC 37° – geschmiedet SAE-45° flange adapter JIC 37° – forged	WFG -...-45-J 76
	SAE-Einschraub-Gegenflansch BSPP-Gewinde SAE-pipe threaded flange BSPP-companion	GFS-...G 50/ 51		SAE-Außengewinde Adapter BSPP Gewinde SAE-flange adapter BSPP thread	SFCE-...- G 77
	SAE-90° Einschraubflansch BSPP-Gewinde SAE-90° threaded flange BSPP	AFS-.../90G 52/ 53		SAE-90° Flansch Adapter Gewinde BSPP 60° – geschmiedet SAE-90° flange adapter BSPP-60° – forged	WFG -...G 78
	SAE-Einschraubflansch NPT-Gewinde..... SAE-threaded flange NPT	AFS-...N 54/ 55		SAE-45° Flansch Adapter BSPP 60° – geschmiedet SAE-45° flange adapter BSPP-60° – forged	WFG -...-45-G 79
	SAE-Einschraub-Gegenflansch NPT-Gewinde SAE-threaded flange NPT-companion	GFS-...N 56		SAE-Außengewinde Adapter UN-ORS SAE-adapter UN-ORS threaded	SORS-... 80
	SAE-90° Einschraubflansch NPT-Gewinde SAE-90° threaded flange NPT	AFS-.../90N 57		SAE-90° Außengewinde Adapter UN-ORS SAE-90° adapter UN ORS threaded	WORS-... 81
	SAE-Einschraubflansch UN/UNF Gewinde SAE-threaded flange UN/UNF	AFS-...T 58/ 59		SAE-45° Außengewinde Adapter UN-ORS SAE-45° adapter UN ORS threaded	WORS-...- 45-... 82
SAE-Außengewindeflansche SAE-threaded flange			SAE-Verschlussflansche SAE-closed flange		
	SAE-Außengewinde Adapter-24° DIN 3901 SAE-flange adapter metric 24° DIN 3901	SFCE-...L/S 60/ 61		SAE-Blindstopfen SAE-plugs	BL/BLO-... 83
	SAE-Außengewindeflansch 24° DIN 3901 SAE-flange metric tapped 24° DIN 3901	AFG-...L/S 62/ 63		SAE-Blindstopfen SAE-plugs	BS/BSO-... 84
	SAE-Außengewinde-Gegenflansch 24° DIN 3901..... SAE-flange metric tapped 24° companion DIN 3901	GFG-...L/S... 64/ 65		SAE-Verschlussflansch SAE-closed flange	AFC-... 85
	SAE-90° Flansch-Adapter – 24° DIN 3901 – geschmiedet SAE-90° flange adapter – 24° DIN 3901 – forged	WFG-.../L/S 66/ 67		SAE-Verschluss-Gegenflansch SAE-closed flange companion	GFC-... 86
	SAE-90° Flansch-Adapter 24° – DIN 3901 – gelötet SAE-90° flange adapter – 24° DIN 3901 – brazed	SFCE-.../90- L/S 68		SAE-Abschlussplatte SAE-locking sheet	AP-... 87
	SAE-90° Außengewindeflansch 24° DIN 3901 SAE-90° threaded flange 24° DIN 3901	AFG-.../90M- L/S 69		SAE-Abschlussplatte mit O-Ringnut SAE-locking sheet with o-ringgroove	APO-... 88
				SAE-Flansch mit Messanschluss – gerader Abgang SAE-flange with test-point – straight	AFC-...G 89





SAE-Zwischenflansche
SAE-adapter flange

	SAE-Zwischenplatte ZP-...	90
	<i>SAE-adapter sheet</i>	
	SAE-Zwischenflanschplatte ZFG-...	91
	<i>SAE-connector flange</i>	
	SAE-Zwischenflansch mit Messanschluss AGL-...	92
	<i>SAE-adapter flange with test-point</i>	





SAE-Reduzierflansche
SAE-adapter flange

	SAE-Reduzierflansch – gerade G-AF-...	93
	<i>SAE-adapter flange – straight</i>	
	SAE-Aufweitungsflansch – geschweißt E-AF-...	94
	<i>SAE-Extension flange – welded</i>	







SAE-Blöcke
SAE-block

	SAE-90° L-Block L-GD-...	95
	<i>SAE-90° L-block</i>	
	SAE-90° L-Block – Gegenflansch L-BL-...	96
	<i>SAE-90° L-block – companion</i>	
	SAE-90° L-Reduzierblock RED-GD-...	97
	<i>SAE-90° L-reduction</i>	
	SAE-T-Block T-GD-...	98
	<i>SAE-T-block</i>	
	SAE-T-Block – Gegenflanschausführung T-BL-...	99
	<i>SAE-T-Block – companion</i>	









SAE-Adapter-geschweißt
SAE adapter – welded

	SAE-90° Adapter – geschweißt AG-...	100
	<i>SAE-90° adapter – welded</i>	
	SAE-45° Adapter – geschweißt AG-...	101
	<i>SAE-45° adapter – welded</i>	
	SAE-90° Adapter – geschweißt AG-...	102
	<i>SAE-90° adapter – welded</i>	
	SAE-45° Adapter – geschweißt AG-...	103
	<i>SAE-45° adapter – welded</i>	
	SAE-T-Verbinder – geschweißt T-...	104
	<i>SAE-T-connection – welded</i>	





Sonstige SAE-Flansche
Other SAE flanges

	SAE-Bördelflansch BFM-...	105
	<i>SAE-flare flange</i>	
	SAE-Bördelflanschkupplung BFK-...	106
	<i>SAE-flare flange-coupling</i>	
	SAE-Tank-/Saugleitungsflansch SHFL-...	107
	<i>SAE-suction hose flange</i>	
	SAE Einschraubflansch BSPP-Gewinde mit Messanschluss G1/8" (kurze Seite) AFS-...G-A1K	108
	<i>SAE Threaded flange with BSPP thread and measuring connection G1/8" (shortest side)</i>	
	SAE-Einschweißflansch mit Messanschluss G1/8" (kurze Seite) AFS-...S-A1K	109
	<i>SAE Socket weld flange with measuring connection G1/8" (shortest side)</i>	
	SAE Anschweißflansch – zöllig mit Messanschluss G1/8" (kurze Seite) AFS-...ST-A1K	110
	<i>SAE Butt weld imperial flange with measuring connection G1/8" (shortest side)</i>	

Flanschverbindungen ISO 6164
Flange connections ISO 6164



	Anschweißflansch – zentriert – ND 160 – ISO 6164 VKA/VKK-160	111
	<i>Butt weld centering flange – ND 160 – ISO 6164</i>	
	Anschweißflansch – zentriert – ND 250 – ISO 6164 VKA/VKK-250	112
	<i>Butt weld centering flange – ND 250 – ISO 6164</i>	
	Anschweißflansch – zentriert – ND 315 – ISO 6164 VKA/VKK-315	113
	<i>Butt weld centering flange – ND 315 – ISO 6164</i>	
	Anschweißflansch – zentriert – ND 400 – ISO 6164 VKA/VKK-400	114
	<i>Butt weld centering flange – ND 400 – ISO 6164</i>	
	Blindstopfen – zentriert – ND 160 – ISO 6164 VKB-...160	115
	<i>Centering flange plug – ND 160 – ISO 6164</i>	
	Blindstopfen – zentriert – ND 250 ND 315 – ISO 6164 VKB-...	116
	<i>Centering flange plug – ND 250 ND 315 – ISO 6164</i>	
	Blindstopfen – zentriert – ND 400 – ISO 6164 VKB-...400	117
	<i>Centering flange plug – ND 400 – ISO 6164</i>	
	90°-Anschweißflansch – zentriert – ISO 6164 VKW	118
	<i>90°-Butt weld centering flange – ISO 6164</i>	
	Flanschverbinder VKV	119
	<i>T-flange connector</i>	

Flanschverbindungen CETOP
Flange connections CETOP

	Seite Page
 Cetop-Anschweißflansch CET 120 <i>Cetop-butt weld flange</i>	120
 Cetop-Anschweißflanschkupplung DCET... 121 <i>Cetop-butt weld flange-coupling</i>	121
 Cetop-Blindflansch BS- 122 <i>Cetop-flange plug</i>	122
 Cetop 90° Anschweißflansch CET-.../90 123 <i>Cetop 90° butt weld flange</i>	123

Havit Haltering-System
Havit retainer ring system





Haltering-Vollflansche
Retainer ring full flange

 SAE-Haltering Vollflansche 3000/6000 PSI RRF-... 124 <i>SAE-retaining flange</i>	124
 ISO 6164 - Vierkant-Halteringflansch VKR-... 125 <i>retain ring flange</i>	125

ISO 6162 - 3000 PSI

 SAE-Haltering Anschweißflansch - 3000 PSI RRF-3... 126/ <i>SAE-retain ring welding system</i> 127	126/ 127
 SAE-Haltering Anschweißkupplung - 3000 PSI RRK-3... 128/ <i>SAE-retain ring welding system</i> 129	128/ 129
 SAE-Haltering Reduzierflansch - 3000 PSI RRF-RED-3... 130 <i>SAE-retain ring reduction system</i>	130
 SAE-Haltering Schottflanschkupplung - 3000 PSI RRF-B-3... 131 <i>SAE-retain bulkhead system</i>	131

ISO 6162-6000 PSI

 SAE-Haltering Anschweißflansch - 6000 PSI RRF-6... 132/ <i>SAE-retain ring welding system</i> 133	132/ 133
 SAE-Haltering Anschweißkupplung - 6000 PSI RRK-6... 134/ <i>SAE-retain ring welding system</i> 135	134/ 135
 SAE-Haltering Reduzierflansch - 6000 PSI RRF-RED-6... 136 <i>SAE-retain ring reduction system</i>	136
 SAE-Haltering Schottflanschkupplung - 6000 PSI RRF-B-6... 137 <i>SAE-retain bulkhead system</i>	137

ISO 6164 - 350-400 Bar





 ISO 6164 - Haltering Anschweißflansch - 350-400 Bar VKR-... 138/ <i>retain welding flange</i> 139	138/ 139
 ISO 6164 - Haltering Anschweißkupplung - 350-400 Bar VKRK-... 140/ <i>SAE-retain ring welding system</i> 141	140/ 141
 ISO 6164 - Haltering Reduzierflansch - 350-400 Bar VKR-RED-... 142 <i>retain ring reduction system</i>	142
 ISO 6164 - Haltering Schottflanschkupplung - 350-400 Bar VKR-B-... 143 <i>retain bulkhead system</i>	143
 Haltering RETAIN-RING-... 144 <i>Retain Ring</i>	144
 Verbunddichtung BOND-... 145 <i>Bonded Seal</i>	145

Havit SAE Bördelflansche System mit Dichtring
Havit SAE flare flange with seal



Bördelvollflansche
SAE-flare flange



 SAE-Bördelvollflansche 3000/6000 PSI ... FF- 146/ <i>SAE-flare flange</i> 147	146/ 147
---	-------------

ISO 6162 - 3000 PSI











 SAE-Bördelflansch mit Dichtring FFA-3... 148/ <i>SAE-flare flange typ A with seal</i> 149	148/ 149
 SAE-Bördelgegenflansch FFB-3... 150/ <i>SAE-flare flange with seal typ B</i> 151	150/ 151
 SAE-Bördelflansch mit Verbunddichtung FFC-3... 152/ <i>SAE-flare flange typ C with seal</i> 153	152/ 153
 SAE-Bördelflanschkupplung Typ D - 3000 PSI FFD-3... 154/ <i>SAE-flare flange typ D</i> 155	154/ 155

ISO 6162 - 6000 PSI



 SAE-Bördelflansch mit Dichtring FFA-6... 156/ <i>SAE-flare flange typ A with seal</i> 157	156/ 157
 SAE-Bördelgegenflansch FFB-6... 158/ <i>SAE-flare flange with seal typ B</i> 159	158/ 159

		Seite Page
	SAE-Bördelflansch mit Verbunddichtung FFC-6... SAE-flare flange with seal typ C	160/ 161
	SAE-Bördelflanschkupplung Typ D - 6000 PSI FFD-6... SAE-flare flange typ D with seal	162/ 163

Anschlüsse für Zahnradpumpenflansche Connections for gear pump-flanges

	Flanschverschraubung – gerade 24° DIN 3901 GF-...L/S Flange connection – straight 24° DIN 3901	164
	Flanschverschraubung 90° – 24° DIN 3901 WF-...L/S Flange connection 90° – 24° DIN 3901	165
	Flanschverschraubung 90° – 24° DIN 3901 3-Loch WF-...L/S-3 Flange connection 90° – 24° DIN 3901 3-hole	166
	Flanschverbindung gerade Gewinde UN-ORS GF - ... UN Straigh flange connection UN-ORS	167
	Flanschverbindung 90° Gewinde UN/ORS WF - ... UN Flange connection 90° UN-ORS	168
	3-Loch Flansch 90° BSPP-Gewinde Stahl WDS-... 3-hole flange 90° BSPP-threaded steel	169
	4-Loch Flansch 90° BSPP-Gewinde Stahl WF - G 4-hole flange 90° BSPP-threaded steel	170
	3-Loch Flansch 90° BSPP-Gewinde Aluminium WDA-... 3-hole flange 90° BSPP-threaded aluminium	171
	4-Loch Flansch 90° BSPP-Gewinde Aluminium WVA-... 4-hole flange 90° BSPP-threaded aluminium	172
	4-Loch Einschweißflansch 90° WF-...E 4-hole socket weld flange 90°	173
	4-Loch Flanschanschluss – gerade F,Fi,FE,FB-... 4-hole flange connection straight	174

Rohrbögen, T-Stücke, Reduzierstücke elbow, tee's and reducers

	Rohrbögen 90° DIN EN 10253-2 RB90-... elbow 90°	175
	T-Stücke DIN EN 10253-2 T-... tee's	176
	Reduzierstücke DIN EN 10253-2 REK-... reducers	177

Angewandte Normen

Für unsere Flansche werden folgende Normen berücksichtigt:

- SAE-Flansche SAE-flanges	Norm: standard:	SAE J 518 C, ISO 6162
- CETOP-Flansche Cetop-flanges	Norm: standard:	CETOP RP 63H, ISO 6164
- Vierkantflansche 4-bolt square flanges	Norm: standard:	ISO/DIS 6164

Used standards

Havit flanges are based on the following standards:

Druckangaben

Der zugehörige maximale Betriebsdruck ist bei jeder Einzelposition aufgeführt.

Bitte beachten Sie daher die Druckangabe vor dem Einsatz.

Alle Druckangaben gehen von einer Einsatztemperatur zwischen -40° Celsius und +90° Celsius aus. Außerhalb dieses Temperaturbereiches werden die physikalischen Eigenschaften des verwendeten Materials beeinflusst, was den Betriebsdruck reduziert.

Die angegebenen Maximalbetriebsdrücke beziehen sich ausschließlich auf die Flanschverbindung. Für die eingesetzten Rohre, Verschraubungen und Armaturen sind die jeweiligen Druckangaben der Hersteller zu berücksichtigen.

Pressure rates

The maximum recommended working pressure is indicated in each article.

Please note the appropriate pressure directives before using a part.

All pressure directives are based on a working temperature from -40° celsius up to +90° celsius. Beyond this temperature range, the physical properties of the used material are effected and the maximum recommended working pressure is reduced accordingly.

The indicated working pressure refers only to the flange itself.

For used tubes, fittings and connections, the pressure directives of the respective manufacturer are the determining factor.

Werkstoffe

Die verwendeten Einsatzmaterialien für die unterschiedlichen Flanschverbindungen sind für jede Produktgruppe angeführt.

Wahlweise können nach Ermessen des Herstellers teilweise verschiedene Werkstoffe verwendet werden.

Used materials

Materials used for each product group are given.

The manufacturer can within reason determine freely whether varying materials are to be implemented.

Einbausätze

Wahlweise werden die Flanschverbindungen mit Zubehör (Schraubensatz und Dichtring) geliefert.

Die Bestellbezeichnung hierfür ist dem Beispiel im Anhang an die Typenbezeichnung zu entnehmen.

Flange kits

If required, all flange connections can be supplied with accessories (bolt set and o-ring).

The respective order code is then to be given as shown in the attached example.

Verwendete Schrauben Used bolts		
SAE-Flansche Die ISO 6162 gibt den maximalen Betriebsdruck für Schrauben mit Festigkeitsklasse 10.9 an. Entsprechende Werte befinden sich bei den jeweiligen Einzelartikeln.		SAE-Flanges The ISO 6162 indicates the maximum operating pressure for bolts with a strength class of 10.9. The working pressures are given in the respective articles.
Havit verwendet grundsätzlich: 1. bei blanken Schrauben - 10,9 2. bei beschichteten Schrauben - Schrauben 10.9: FIZn 480h L beschichtet 3. bei Edelstahl - A4-80		Havit supplies: 1. blank bolts - 10.9 2. bolts with surface - bolts grade 10.9: FIZn 480h L 3. stainless steel - A4-80
Metrische Schrauben: metric bolts:		DIN 912-10.9 (ISO 4762-10.9) -FIZn 480h L
Zöllige Schrauben: UNC bolts:		ASA B 18.3 - grade 10
Zahnradpumpenflansche gear pump flanges	Metrische Schrauben: metric bolts	DIN 912-8.8 (ISO 4762-8.8) ZnNi
Vierkantflanschverbindungen 4-Bolt square flanges	Metrische Schrauben: metric bolts	DIN 912 / 931/933-8.8 (ISO 4762 / 4014 / 4017-8.8) oder/or DIN 912 / 931/933-10.9 (ISO 4762 / 4014 / 4017-10.9)
Cetop-Flansche Cetop flanges	Metrische Schrauben: metric bolts	DIN 912 / 931/933-8.8 (ISO 4762 / 4014 / 4017-8.8) oder/or DIN 912 / 931/933-10.9 (ISO 4762 / 4014 / 4017-10.9)

Dichtungen

Alle Flanschverbindungen dieses Kataloges dichten mit einer Rundringdichtung. Unsere Dichtungen sind lieferbar in folgenden Materialien:

- Perbunan Härte 90 Shore (Standard)
- Viton Härte 85-90 Shore (auf Wunsch)

Bei SAE Flanschen und CETOP Flanschen werden grundsätzlich die O-Ringabmessungen gemäß nachstehender Tabelle berücksichtigt. Sind andere als diese standardisierten O-Ringe vorgesehen so sind diese bei den Einzelartikeln angeführt.

Größe size	A	B
3/8"	17,12	2,62
1/2"	18,66	3,53
3/4"	25,00	3,53
1"	32,92	3,53
1 1/4"	37,70	3,53
1 1/2"	47,22	3,53
2"	56,75	3,53
2 1/2"	69,45	3,53
3"	85,32	3,53
3 1/2"	98,02	3,53
4"	110,72	3,53
5"	136,12	3,53

Seals

All flange connections shown in this catalogue are sealed using o-rings. The o-rings supplied by Havit are made from the following materials:

- buna 90 shore (standard)
- viton 85-90 shore (option)

For all SAE flanges and Cetop flanges, the o-ring dimensions are to be read as according to the following table.

O-rings differing from these dimensions are listed in the respective articleshowing their exact dimensions accordingly.

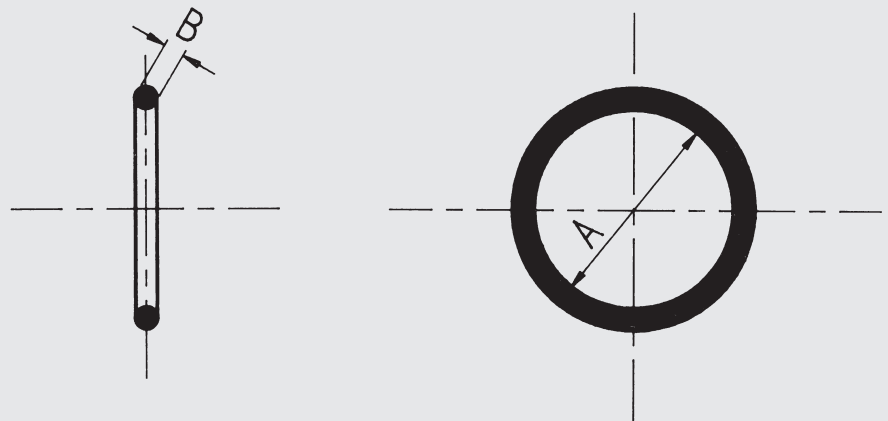

Oberflächenschutz

Soweit bei den einzelnen Artikelgruppen keine Angaben gemacht sind, werden die Flanschverbindungen als Blankstahl – mit Korrosionsschutz versehen – geliefert.

Surface protection

As far as no special directives exist on a product range, all flanges are delivered in blank steel and coated to protect against corrosion.

Verrohrung von Flanschverbindungen

Wir empfehlen für die Verrohrung unserer Flansche die Verwendung der folgenden Rohre:

- Präzisionsrohre nach DIN EN 10305-1, Güteklasse C normalisierend blankgeglüht (NBK) und nahtlos blankgezogen
Material: ST 37-4 oder ST 52-4
- nahtlose Siederohre nach DIN EN 10220, Reihe 1 und 2 aus St 37-4 und ST 52-4
- Rohre nach ASME B36.10M

Für die einzelnen Flanschgrößen und Druckstufen empfehlen wir folgende Rohrabmessungen:

Flange tube connections

For tube connections with our flanges we recommend tubes which meet with the following standards:

- seamless precision steel pipes to DIN EN 10305-1, grade C materials ST 37-4 or ST 52-4
- seamless boiler tubes to DIN EN 10220, group 1 and 2 from materials ST 37-4 and ST 52-4
- tubes according to ASME B36.10M

For the flange sizes and pressure rates we recommend the following tube dimensions:

Flanschgröße flange size	Rohre nach DIN EN 10305-1 tubes to DIN EN 10305-1					Rohre nach DIN EN 10220 tubes to DIN EN 10220		Rohre nach ASME B36.10M tubes to ASME B36.10M			
	Reihe / series					Reihe / series		Reihe / series			
inch	100 bar	160 bar	250 bar	315 bar	400 bar	250 bar	400 bar	schedule	250 bar	schedule	400 bar
1/2"	15 x 1	18 x 1,5	16 x 2	16 x 2,5	16 x 3	21,3 x 2,6	21,3 x 3,2	40	21,3 x 2,8	80	21,3 x 3,7
	18 x 1		20 x 2,5	20 x 3	20 x 3,5						
3/4"	-	-	25 x 3	25 x 3,5	25 x 4	26,9 x 2,6	26,9 x 4	40	26,7 x 2,9	80	26,7 x 3,9
1"	28 x 2	-	28 x 3	30 x 5	30 x 6	33,7 x 4	33,7 x 6,3	40	33,7 x 4,8	160	33,7 x 6,4
			30 x 4								
1 1/4"	35 x 2	-	35 x 4	38 x 6	38 x 7	42,4 x 5	42,4 x 6,3	80	42,4 x 4,8	160	42,4 x 6,4
			38 x 5								
1 1/2"	42 x 3	-	42 x 5	50 x 8	50 x 9	48,3 x 5	48,3 x 8	80	48,3 x 5,1	160	48,3 x 7,1
			50 x 6								
2"	-	-	-	65 x 8	65 x 10	60,3 x 6,3	60,3 x 10	160	60,3 x 8,7	200	60,3 x 11,1
2 1/2"	-	-	-	80 x 10	80 x 12	76,1 x 8	76,1 x 12,5	160	73 x 9,5	200	73 x 14
3"	-	-	-	-	-	88,9 x 10	88,9 x 16	160	88,9 x 11,1	200	88,9 x 15,2
3 1/2"	-	-	-	-	-	101,6 x 10	101,6 x 16	-	-	-	-
4"	-	-	-	-	-	114,3 x 12,5	114,3 x 20	160	114,3 x 13,5	200	114,3 x 17,1

Verwendete Schrauben: Schraubenanzugsmomente und Drücke für Flanschverbindungen
Used Bolts: Screw torques and pressures of flanged port assemblies

Schrauben 10.9 Bolts 10.9				
Nenngröße nominal size		Durchmesser diameter	Anzugsmomente tightening torques	maximaler Betriebsdruck maximum recommended working pressure
ISO [DN]	SAE [inch]		$^{+10\%}_0$ [NM]	[bar]
Standarddruckreihe (nach ISO 6162-1) <i>Standard pressure series (according to ISO 6162-1)</i>				3.000 PSI <i>3.000 PSI</i>
13	1/2"	M8	32	350
19	3/4"	M 10	70	350
25	1"	M 10	70	320
32	1 1/4"	M 10	70	280
38	1 1/2"	M 12	130	210
51	2"	M 12	130	210
64	2 1/2"	M 12	130	175
76	3"	M 16	295	160
89	3 1/2"	M 16	295	35
102	4"	M 16	295	35
127	5"	M 16	295	35
Hochdruckreihe (nach ISO 6162-2) <i>High pressure series (according to ISO 6162-2)</i>				6.000 PSI <i>6.000 PSI</i>
13	1/2"	M8	32	420
19	3/4"	M 10	70	420
25	1"	M 12	130	420
32	1 1/4"	M 12	130	420
32	1 1/4"	M 14 ^{*1}	180	420
38	1 1/2"	M 16	295	420
51	2"	M 20	550	420

Schrauben UNC Grade 8 Bolts UNC grade 8				
Nenngröße nominal size		Durchmesser diameter	Anzugsmomente tightening torques	maximaler Betriebsdruck maximum recommended working pressure
ISO [DN]	SAE [inch]		$^{+10\%}_0$ [NM]	[bar]
Standarddruckreihe (nach ISO 6162-1) <i>Standard pressure series (according to ISO 6162-1)</i>				3.000 PSI <i>3.000 PSI</i>
13	1/2"	5/16-18	32	350
19	3/4"	3/8-16	60	350
25	1"	3/8-16	60	315
32	1 1/4"	7/16-14	92	250
38	1 1/2"	1/2-13	150	200
51	2"	1/2-13	150	200
64	2 1/2"	1/2-13	150	160
76	3"	5/8-11	295	160
89	3 1/2"	5/8-11	295	35
102	4"	5/8-11	295	35
127	5"	5/8-11	295	35
Hochdruckreihe (nach ISO 6162-2) <i>High pressure series (according to ISO 6162-2)</i>				6.000 PSI <i>6.000 PSI</i>
13	1/2"	5/16-18	32	400
19	3/4"	3/8-16	60	400
25	1"	7/16-14	92	400
32	1 1/4"	1/2-13	150	400
38	1 1/2"	5/8-11	295	400
51	2"	3/4-10	450	400

Hinweise/Notes

*1 Nicht für Neukonstruktionen zu verwenden.
Not to be used for new constructions.

*2 Die angegebenen Anzugsmomente für UNC-Schrauben sind der Norm ISO 6162-1/2 entnommen und beziehen sich auf die Festigkeitsklasse "Grade 8". Verfügbar sind jedoch nur Schrauben der höheren Festigkeitsklasse "Grade 10".
The tightening torques for UNC bolts as stated on the left apply to "grade 8" UNC bolts according to ISO 6162-1/2. Please note that we only have UNC bolts of the higher "grade 10" available.

Achtung: Alle Schrauben sind leicht anzuziehen, bevor das erforderliche Anzugsdrehmoment aufgebracht wird. Andernfalls kann es zum Bruch des Flansches kommen.

Attention: All bolts have to be pre-tightened before applying the full tightening torque to the bolts. Otherwise, the flange may break.

Die angegebenen Drehmomente sind Empfehlungswerte. Sie beziehen sich auf geölte Schrauben, berechnet mit einem Reibbeiwert von 0,17 und der Materialpaarung Stahl/Stahl. Der zugelassene Wert hängt von vielen Faktoren (insbesondere Werkstoffe, Oberfläche, Beschichtung und Schmierung der zu verschraubenden Teile) ab und ist vom Anwender zu ermitteln.

Please note that the tightening torques as stated above are only recommendations. These values correspond to oiled bolts with a friction coefficient of 0,17 and the material combination steel/steel. The exact tightening torques depend on factors like material, finishing, coating and lubrication of the components used, and have to be determined by the user himself.

Montageanleitung - Flansche
Mounting instructions - flange

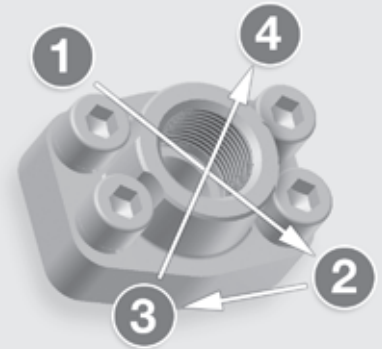
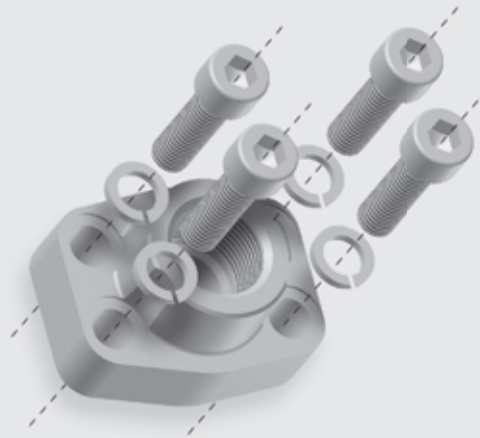
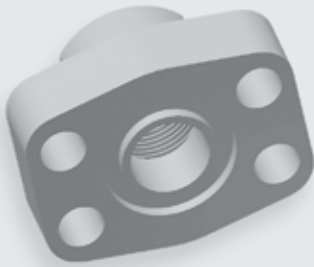

Schritt 1

- Prüfen Sie die Dichtfläche und O-Ringnut. Diese müssen von Graden, fremden Partikeln und sonstigen Beschädigungen frei sein
- O-Ring mit Systemflüssigkeit schmieren und in die O-Ringnut einlegen

Step 1

- Check the connecting surface and the O-ring groove. Both must be free of all scratches, particles and any damage
- Smear the O-ring with system fluid and place it in the O-ring groove

Schritt 2

- Positionierung des Flansches zum Gegenstück
- Handfeste Vormontage der Schrauben (mit Federring optional)

Step 2

- Position the flange against the matching component
- Mount the bolts and initially tighten per hand (spring washer is optional)

Schritt 3

- Festdrehen der Schrauben, in der Reihenfolge 1-4, auf das empfohlene Anzugsmoment
- **WICHTIG:** Alle Schrauben müssen vor dem Aufbringen des empfohlenen Anzugsmomentes leicht angezogen werden, damit ein Bruch vermieden wird

Step 3

- Tighten the bolts in the displayed sequence according to the recommended torque
- **IMPORTANT:** To avoid damage, tighten each bolt lightly in sequence before administering the recommended torque

		Schrauben 10.9 Bolts 10.9			Schrauben UNC Grade 8 ^{*2} Bolts UNC grade 8 ^{*2}		
Nenngröße nominal size		Durchmesser diameter	Anzugsmomente tightening torques	maximaler Betriebsdruck max. recomm. working pressure	Durchmesser diameter	Anzugsmomente tightening torques	maximaler Betriebsdruck max. recomm. working pressure
ISO [DN]	SAE [inch]		^{+10%} ₀ [NM]	[bar]		^{+10%} ₀ [NM]	[bar]
Standarddruckreihe (nach ISO 6162-1)							3.000 PSI
Standard pressure series (according to ISO 6162-1)							3.000 PSI
13	1/2"	M 8	32	350	5/16-18	32	350
19	3/4"	M 10	70	350	3/8-16	60	350
25	1"	M 10	70	320	3/8-16	60	320
32	1 1/4"	M 10	70	280	7/16-14	92	280
38	1 1/2"	M 12	130	210	1/2-13	150	210
51	2"	M 12	130	210	1/2-13	150	210
64	2 1/2"	M 12	130	175	1/2-13	150	175
76	3"	M 16	295	160	5/8-11	295	160
89	3 1/2"	M 16	295	35	5/8-11	295	35
102	4"	M 16	295	35	5/8-11	295	35
127	5"	M 16	295	35	5/8-11	295	35
Hochdruckreihe (nach ISO 6162-2)							6.000 PSI
High pressure series (according to ISO 6162-2)							6.000 PSI
13	1/2"	M 8	32	420	5/16-18	32	420
19	3/4"	M 10	70	420	3/8-16	60	420
25	1"	M 12	130	420	7/16-14	92	420
32	1 1/4"	M 12	130	420	1/2-13	150	420
32	1 1/4"	M 14 ^{*1}	180	420	-	-	-
38	1 1/2"	M 16	295	420	5/8-11	295	420
51	2"	M 20	550	420	3/4-10	450	420
64	2 1/2"	M 24	550	420			
76	3"	M 30	650	420			

*1 Nicht für Neukonstruktionen zu verwenden.
Not to be used for new constructions.

*2 Die angegebenen Anzugsmomente für UNC-Schrauben sind der Norm ISO 6162-1/2 entnommen und beziehen sich auf die Festigkeitsklasse "Grade 8". Verfügbar sind jedoch nur Schrauben der höheren Festigkeitsklasse "Grade 10".
The tightening torques for UNC bolts as stated on the left apply to "grade 8" UNC bolts according to ISO 6162-1/2. Please note that we only have UNC bolts of the higher "grade 10" available.

Anzugsmoment und max. Arbeitsdruck nach ISO 6162
Torque and max. working pressure according to ISO 6162

Stahl								
		Schrauben 10.9 Bolts 10.9			UNC-Schraube Grade 8 ** Bolts UNC grade 8 **			
Nenngröße nominal size		Durchmesser diameter	Anzugsmomente* tightening torques*	maximaler Betriebsdruck max. recomm. working pressure	Durchmesser diameter	Anzugsmomente* tightening torques*	maximaler Betriebsdruck max. recomm. working pressure	
ISO [DN]	SAE [inch]		^{+10%} ₀ [NM]	[bar]		^{+10%} ₀ [NM]	[bar]	
Standarddruckreihe (ISO 6162-1) standard pressure series								
13	1/2"	M 8	32	350	5/16-18	32	350	
19	3/4"	M 10	70	350	3/8-16	60	350	
25	1"	M 10	70	320	3/8-16	60	320	
32	1 1/4"	M 10	70	280	7/16-14	92	280	
38	1 1/2"	M 12	130	210	1/2-13	150	210	
51	2"	M 12	130	210	1/2-13	150	210	
64	2 1/2"	M 12	130	175	1/2-13	150	175	
76	3"	M 16	295	160	5/8-11	295	160	
89	3 1/2"	M 16	295	35	5/8-11	295	35	
102	4"	M 16	295	35	5/8-11	295	35	
127	5"	M 16	295	35	5/8-11	295	35	
Hochdruckreihe (ISO 6162-2) high pressure series								
13	1/2"	M 8	32	420	5/16-18	32	420	
19	3/4"	M 10	70	420	3/8-16	60	420	
25	1"	M 12	130	420	7/16-14	92	420	
32	1 1/4"	M 12	130	420	1/2-13	150	420	
38	1 1/2"	M 16	295	420	5/8-11	295	420	
51	2"	M 20	550	420	3/4-10	450	420	
64	2 1/2"	M 24	550	420	-	-	-	
76	3"	M 30	650	420	-	-	-	

Hinweise/Notes

Warnung: Alle Schrauben müssen vor dem Aufbringen des empfohlenen Anzugsmoments leicht angezogen werden, damit ein Bruch vermieden wird.
Important: To avoid damage, tighten each bolt lightly in before administrating the recommended torque.

* Diese Anzugsmomente sind als Anleitung zu sehen, wenn geschmierte Schrauben mit einem Reibungskoeffizienten von 0,17 verwendet werden. Das tatsächliche Anzugsmoment hängt von vielen Faktoren ab. Wie z.B. Schmierung, Oberflächenbehandlung und -zustand.

These torque values are only a guide when using lubricated screws, calculated with a coefficient of friction 0,17. Net tightening torque depends on many factors, including lubrication, coating and surface finish.

** Die angegebenen Anzugsmomente für UNC Schrauben sind der Norm ISO 6162-1/2 entnommen und beziehen sich auf die Festigkeitsklasse "Grade 8". Verfügbar sind jedoch nur Schrauben der höheren Festigkeitsklasse "Grade 10".

The tightening torques for UNC bolts as stated on the left apply to "grade 8" UNC bolts according to ISO 6162-1/2. Please note that we only have UNC bolts of the higher "grade 10" available.

Anzugsmoment und max. Arbeitsdruck nach ISO 6164
 Torque and max. working pressure according to ISO 6164

Stahl								
		Schraube 8.8 Bolts 8.8			Schraube 10.9 ** Bolts 10.9 **			
Nenngröße nominal size	Durchmesser diameter	Anzugsmomente* tightening torques*	maximaler Betriebsdruck max. recomm. working pressure	Durchmesser diameter	Anzugsmomente* tightening torques*	maximaler Betriebsdruck max. recomm. working pressure		
ISO [DN]	ISO 6164							Schrauben- hersteller µges.=0,14
10	4x	M6	10	250	M6	13	400	17
13	4x	M8	25	250	M8	31	400	40
19	4x	M8	25	250	M8	31	400	40
25	4x	M10	53	250	M10	66	400	79
32	4x	M12	95	250	M12	119	400	137
38	4x	M16	220	250	M16	275	400	338
51	4x	M16	220	250	M16	275	400	338
56	4x	M20	390	250	M20	488	400	661
63	4x	M20	390	250	M24	1.000	400	1.136
70	4x	–	–	–	M24	1.000	400	1.136
80	4x	–	–	–	M30	2.000	400	2.274
100	8x		–	–	M24	1.136	–	
125	8x		–	–	M30	2.274	–	
150	8x		–	–	M36	3.957	–	

Hinweise/Notes

* Diese Anzugsmomente sind als Anleitung zu sehen, wenn geschmierte Schrauben mit einem Reibungskoeffizienten von 0,2 verwendet werden. Das tatsächliche Anzugsmoment hängt von vielen Faktoren ab.

These torque values are only a guide when using lubricated screws, calculated with a coefficient of friction 0,2. Net tightening torque depends on many factors, including lubrication, coating and surface finish.

** Bei Verwendung der Festigkeitsklasse 10.9 errechnet sich das Anzugsmoment aus der Festigkeitsklasse 8.8 +25%.

When the strength class 10.9 is used, the tightening torque is calculated from the strength class 8.8 + 25%..

Zahnradpumpen (8.8 - ZN)				
WDS,WF-	LK-30-ORS	M5	4,82	
	LK-30/35/40	M6	8,37	
	LK-40	M8	20,17	
	LK-55	M8	20,17	
WDS	LK-51/56	M10	39,7	
WDA, F	LK-62/72,5	M12	68,3	

Anzugsmoment und max. Arbeitsdruck nach CETOP (RP 63 H)
 Torque and max. working pressure according to CETOP (RP 63 H)

Stahl							
		Schraube 8.8 Bolts 8.8			Schraube 10.9 Bolts 10.9		
Nenngröße nominal size		Durchmesser diameter	Anzugsmomente* tightening torques*	maximaler Betriebsdruck max. recomm. working pressure	Durchmesser diameter	Anzugsmomente* tightening torques*	maximaler Betriebsdruck max. recomm. working pressure
			$\begin{matrix} +10\% \\ 0 \end{matrix} [NM]$	[bar]		$\begin{matrix} +10\% \\ 0 \end{matrix} [NM]$	[bar]
Rohr tube	inch	CETOP (RP 63 H)					
16		M6	10	100 / 250 / 400	M6	13	400
20		M8	25	100 / 250 / 400	M8	31	400
25		M8	25	100 / 250 / 400	M8	31	400
30		M10	49	100 / 250 / 400	M10	66	400
32	400						
38		M12	86	100 / 250 / 400	M12	119	400
40	400						
48,3		M14	135	100 / 250 / 400	M14	218	400
50	400						
60,3		M16	210	100 / 250 / 400	M16	275	400
76,1		M20	410	100 / 250 / 400	M20	488	400
88,9		M20	410	100 / 250 / 400	M20	488	400
101,6		M24	710	100 / 250 / 400	M24	1.000	400
114,3		M24	710	100 / 250 / 400	M24	1.000	400

Hinweise/Notes

* Diese Anzugsmomente sind als Anleitung zu sehen, wenn geschmierte Schrauben mit einem Reibungskoeffizienten von 0,14 verwendet werden. Das tatsächliche Anzugsmoment hängt von vielen Faktoren ab. Wie z.B. Schmierung, Oberflächenbehandlung und -zustand.

These torque values are only a guide when using lubricated screws, calculated with a coefficient of friction 0,14. Net tightening torque depends on many factors, including lubrication, coating and surface finish.

Anzugsmoment gemäß Schraubenhersteller
Torque according to bolt manufacturer

Ø	Anziehungsmoment in Nm (metrische Schrauben)					
	Stahl			Edelstahl		
	8.8 ZN	10.9 FLZN	10.9 blank	A4-80		
Reibungszahl	µges.=0,09	µges.=0,09	µges.=0,14	µges.=0,2	µges.=0,3	µges.=0,4
M5	4,82	7,08	9,5	7,4	9,1	10,2
M6	8,37	12,3	16,5	12,9	15,8	17,7
M8	20,17	29,63	40,1	31,5	38,8	43,4
M10	39,7	58,3	79	62,4	77,1	86,2
M12	68,3	100	137	108	133,6	149,5
M14	–	160	218	172	212	238,5
M16	–	245	338	269	334	375
M20	–	480	661	527	656	736
M24	–	825	1136	680*	848*	–
M30	–	1644	2274	1373*	1715*	–
M36	–	2850	3957	1117*	1398*	–

Hinweise/Notes

- * M24, M30 Anzugsmoment für Festigkeit 70
- * M36 Anzugsmoment für Festigkeit 50.

Zusätzliche Schmierung der Gewinde verändert die Reibungszahl erheblich und führt zu unbestimmten Anziehverhältnissen.
 Alle Angaben sind unverbindliche Richtwerte.
 Die genannten Anziehungsmomente können nur als sehr grobe und unverbindliche Richtwerte verstanden werden.

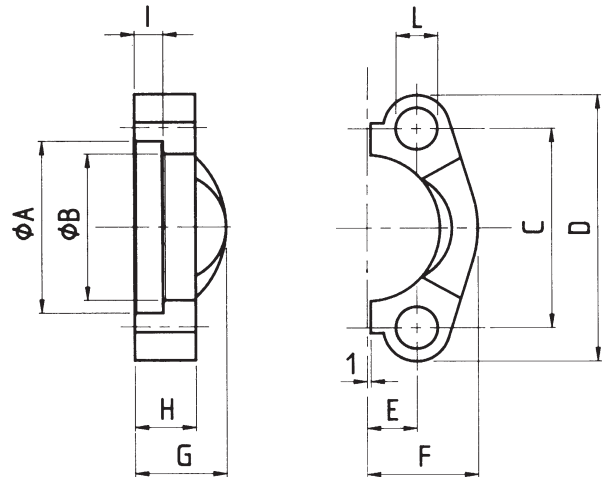

Bestellbezeichnung: ordering code:	S355J2^{*1} C45	1.4404^{*1} 316L
• nur Flansch flange only	FH-...	FH-X-...

maximaler Betriebsdruck maximum recommended working pressure	S.A.E. Baugröße nominal flange size	Typ type	Abmessungen dimensions										Schrauben bolts		Gewicht weight
			A	B	C	D	E	F	G	H	I	L	M	kg	
kg/cm ²	inch												metr.	unc.	
Schraube Festigkeitskl. 10.9			Standarddruckreihe / Standard pressure												
350	1/2"	FH 3001	31,0	24,3	38,1	54	8,75	23	19	13	6,2	8,50	M 8x25	5/16 x 1 1/4	0,07
350	3/4"	FH 3002	38,9	32,2	47,6	65	11,15	26	22	14	6,2	10,50	M 10x30	3/8 x 1 1/4	0,09
320	1"	FH 3003	45,3	38,5	52,4	70	13,10	29	24	16	7,5	10,50	M 10x30	3/8 x 1 1/4	0,11
280	1 1/4"	FH 3004	51,6	43,7	58,7	79	15,10	37	22	14	7,5	12,00	M 10x30	7/16 x 1 1/2	0,15
280	1 1/4"	FH 3014	51,6	43,7	58,7	79	15,10	37	22	14	7,5	10,50	M 10x30	–	0,15
280	1 1/4"	FH 3044	51,6	43,7	58,7	79	15,10	37	22	14	7,5	12,75	M 12x35	–	0,15
210	1 1/2"	FH 3005	61,1	50,8	69,9	94	17,85	41	25	16	7,5	13,30	M 12x35	1/2 x 1 1/2	0,23
210	2"	FH 3006	72,3	62,8	77,8	102	21,45	49	26	16	9,0	13,30	M 12x35	1/2 x 1 1/2	0,25
175	2 1/2"	FH 3007	84,9	74,9	88,9	114	25,40	54	38	19	9,0	13,30	M 12x40	1/2 x 1 1/2	0,37
175	2 1/2"	FH 3007-B 76,6	84,9	76,6	88,9	114	25,40	54	38	19	9,0	13,30	M 12x40	1/2 x 1 1/2	0,37
160	3"	FH 3008	102,4	90,9	106,4	135	30,95	66	41	22	9,0	17,00	M 16x50	5/8 x 2	0,65
35	3 1/2"	FH 3009	115,1	102,4	120,7	152	34,95	70	28	22	10,7	17,00	M 16x50	5/8 x 2	0,75
35	4"	FH 3010	127,8	115,0	130,2	162	38,90	76	35	25	10,7	17,00	M 16x50	5/8 x 2	0,84
35	5"	FH 3011	153,2	140,5	152,4	184	46,05	90	41	28	10,7	17,00	M 16x55	5/8 x 2	1,25
Schraube Festigkeitskl. 10.9			Hochdruckreihe / High pressure												
420	1/2"	FH 6001	32,5	24,6	40,5	56	9,10	24	22	16	7,2	8,50	M 8x30	5/16 x 1 1/4	0,08
420	3/4"	FH 6002	42,0	32,5	50,8	71	11,90	30	28	19	8,2	10,50	M 10x35	3/8 x 1 1/2	0,18
420	1"	FH 6003	48,4	38,8	57,2	81	13,90	35	33	24	9,0	13,30	M 12x45	–	0,27
420	1"	FH 6013	48,4	38,8	57,2	81	13,90	35	33	24	9,0	12,00	–	7/16 x 1 3/4	0,27
420	1 1/4"	FH 6004	54,8	44,5	66,6	95	15,90	39	38	27	9,8	14,60	M 14x50	–	0,40
420	1 1/4"	FH 6044	54,8	44,5	66,6	95	15,90	39	38	27	9,8	13,30	M 12x45	1/2 x 1 3/4	0,40
420	1 1/2"	FH 6005	64,3	51,6	79,3	113	18,25	48	43	30	12,0	16,80	M 16x55	5/8 x 2	0,68
420	2"	FH 6006	80,2	67,6	96,8	133	22,25	57	52	37	12,0	21,00	M 20x70	3/4 x 2 1/2	1,05

Oberfläche: CR-6: auslaufend/Neu: CR-6 frei / surface: CR-6: phase-out/New: CR-6 free
 *1 oder vergleichbare Güte / or comparable material

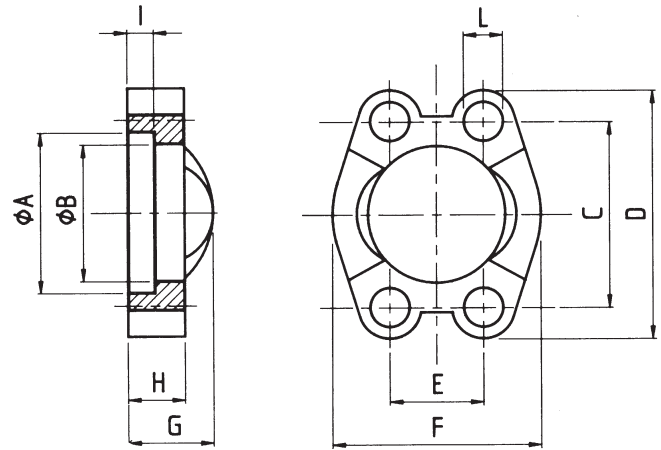

Bestellbezeichnung: ordering code:	S355J2^{*1} C45	1.4404^{*1} 316L
• nur Flansch flange only	VF-...	VF-X-...

maximaler Betriebsdruck maximum recommended working pressure	S.A.E. Baugröße nominal flange size	Typ type	Abmessungen dimensions										Schrauben bolts		Gewicht weight		
			A	B	C	D	E	F	G	H	I	L	metr.	unc.		kg	
kg/cm ²	inch																
Schraube Festigkeitskl.			Standarddruckreihe / Standard pressure														
10.9																	
350	1/2"	VF 3001	31,0	24,3	38,1	54	17,5	46	19	13	6,2	8,50	M 8x25	5/16 x 1 1/4	0,14		
350	3/4"	VF 3002	38,9	32,2	47,6	65	22,3	52	22	14	6,2	10,50	M 10x30	3/8 x 1 1/4	0,17		
320	1"	VF 3003	45,3	38,5	52,4	70	26,2	59	24	16	7,5	10,50	M 10x30	3/8 x 1 1/4	0,22		
280	1 1/4"	VF 3004	51,6	43,7	58,7	79	30,2	73	22	14	7,5	12,00	M 10x30	7/16 x 1 1/2	0,30		
400	1 1/4"	VF 3004-6000 psi	51,6	43,7	58,7	79	30,2	73	33	24	7,5	12,50	M 12x45	–	0,50		
210	1 1/2"	VF 3005	61,1	50,8	69,9	94	35,7	83	25	16	7,5	13,30	M 12x35	1/2 x 1 1/2	0,45		
210	2"	VF 3006	72,3	62,8	77,8	102	42,9	97	26	16	9,0	13,30	M 12x35	1/2 x 1 1/2	0,50		
400	2"	VF 3006-6000 psi	72,3	62,8	77,8	102	42,9	97	43	30	9,0	13,50	M 12x50	–	1,38		
175	2 1/2"	VF 3007	84,9	74,9	88,9	114	50,8	109	38	19	9,0	13,30	M 12x40	1/2 x 1 1/2	0,74		
175	2 1/2"	VF 3007 B-76,6	84,9	76,6	88,9	114	50,8	109	38	19	9,0	13,30	M 12x40	1/2 x 1 1/2	0,8		
160	3"	VF 3008	102,4	90,9	106,4	135	61,9	131	41	22	9,0	17,00	M 16x50	5/8 x 2	1,30		
35	3 1/2"	VF 3009	115,1	102,4	120,7	152	69,9	140	28	22	10,7	17,00	M 16x50	5/8 x 2	1,50		
35	4"	VF 3010	127,8	115,0	130,2	162	77,8	152	35	25	10,7	17,00	M 16x50	5/8 x 2	1,65		
35	5"	VF 3011	153,2	140,5	152,4	184	92,1	181	41	28	10,7	17,00	M 16x55	5/8 x 2	2,50		
Schraube Festigkeitskl.			Hochdruckreihe / High pressure														
10.9																	
420	1/2"	VF 6001	32,5	24,6	40,5	56	18,2	48	22	16	7,2	8,50	M 8x30	5/16 x 1 1/4	0,16		
420	3/4"	VF 6002	42,0	32,5	50,8	71	23,8	60	28	19	8,2	10,50	M 10x35	3/8 x 1 1/2	0,35		
420	1"	VF 6003	48,4	38,8	57,2	81	27,8	70	33	24	9,0	13,30	M 12x45	–	0,53		
420	1"	VF 6013	48,4	38,8	57,2	81	27,8	70	33	24	9,0	12,00	–	7/16 x 1 3/4	0,53		
420	1 1/4"	VF 6004	54,8	44,5	66,6	95	31,8	78	38	27	9,8	14,60	M 14x50	–	0,80		
420	1 1/4"	VF 6044	54,8	44,5	66,6	95	31,8	78	38	27	9,8	13,30	M 12x45	1/2 x 1 3/4	0,80		
420	1 1/2"	VF 6005	64,3	51,6	79,3	113	36,5	95	43	30	12,0	16,80	M 16x55	5/8 x 2	1,35		
420	2"	VF 6006	80,2	67,6	96,8	133	44,5	114	52	37	12,0	21,00	M 20x70	3/4 x 2 1/2	2,10		
420	2 1/2"	VF 6007	108,9	90,5	123,8	180	58,8	152	45	45	20,5	26,00	M 24x80	–	4,10		
420	3"	VF 6008	132,5	115,5	152,4	215	71,6	198	55	55	25,5	32,00	M 30x90	–	8,60		

Oberfläche: CR-6: auslaufend/Neu: CR-6 frei / surface: CR-6: phase-out/New: CR-6 free
*1 oder vergleichbare Güte / or comparable material

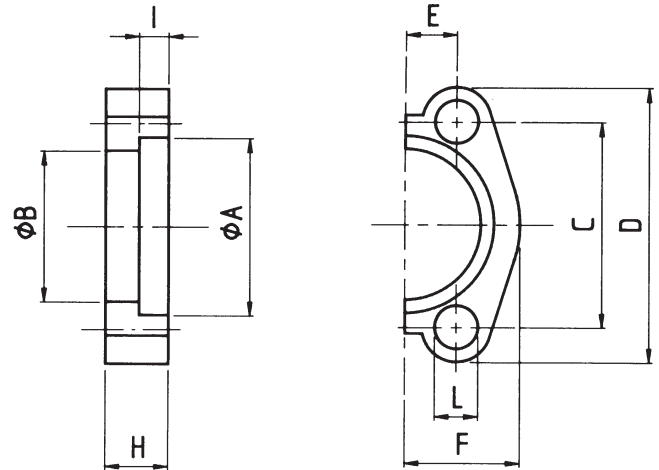

Bestellbezeichnung: ordering code:	C60
• nur Flansch flange only	HF-...

maximaler Betriebsdruck maximum recommended working pressure	S.A.E. Baugröße nominal flange size	Typ type	Abmessungen dimensions									Schrauben bolts		Gewicht weight		
			A	B	C	D	E	F	H	I	L	metr.	unc.		kg	
kg/cm ²	inch															
Schraube Festigkeitskl. 10.9	Standarddruckreihe / Standard pressure											metr.	unc.			
350	1/2"	HF 3001	31,0	24,4	38,1	54	8,75	23,0	13	6,2	9	M 8x25	5/16 x 1 1/4	0,06		
350	3/4"	HF 3002	38,9	32,4	47,6	65	11,15	26,0	14	6,2	11	M 10x30	3/8 x 1 1/4	0,07		
320	1"	HF 3003	45,3	38,5	52,4	70	13,10	29,0	16	7,5	11	M 10x30	3/8 x 1 1/4	0,10		
280	1 1/4"	HF 3004	51,6	43,7	58,7	79	15,10	35,5	16	7,5	11	M 10x30	–	0,15		
210	1 1/2"	HF 3005	61,1	50,8	69,9	94	17,85	38,7	16	7,5	13	M 12x35	1/2 x 1 1/2	0,18		
210	2"	HF 3006	72,3	62,8	77,8	107	21,45	47,7	16	9,0	13	M 12x35	1/2 x 1 1/2	0,22		
Schraube Festigkeitskl. 10.9	Hochdruckreihe / High pressure											metr.	unc.			
420	1/2"	HF 6001	32,5	24,4	40,5	56	9,10	23,5	16	7,2	9	M 8x30	5/16 x 1 1/4	0,08		
420	3/4"	HF 6002	42,0	32,5	50,8	69	11,90	29,0	20	8,2	11	M 10x35	3/8 x 1 1/2	0,16		
420	1"	HF 6003	48,4	38,9	57,2	78	13,90	35,5	25	9,0	13	M 12x45	7/16 x 1 3/4	0,25		
420	1 1/4"	HF 6004	54,8	44,5	66,6	92	15,90	38,7	27	9,8	15	M 14x50	1/2 x 1 3/4	0,34		
420	1 1/2"	HF 6005	64,3	51,5	79,3	107	18,25	47,7	30	12,0	17	M 16x55	5/8 x 2	0,55		
420	2"	HF 6006	80,2	67,6	96,8	133	22,25	57,0	37	12,0	21	M 20x70	3/4 x 2 1/2	1,02		
420	2 1/2"	HF 6007	108,9	90,5	123,8	180	29,40	75,0	45	20,5	26	M 24x80	–	2,05		
420	3"	HF 6008	132,5	115,5	152,4	215	35,80	99,0	55	25,5	32	M 30x90	–	4,30		

Oberfläche: CR-6: auslaufend/Neu: CR-6 frei / surface: CR-6: phase-out/New: CR-6 free

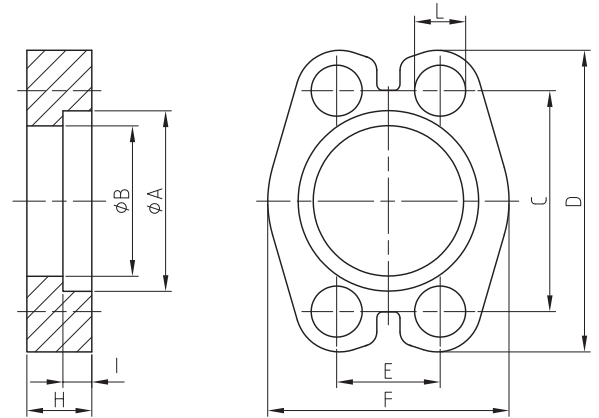

Bestellbezeichnung: ordering code:	C60
• nur Flansch flange only	VFH-...

maximaler Betriebsdruck maximum recommended working pressure	S.A.E. Baugröße nominal flange size	Typ type	Abmessungen dimensions										Schrauben bolts		Gewicht weight	
			A	B	C	D	E	F	H	I	L	M	kg			
kg/cm ²	inch															
Schraube Festigkeitskl.		Standarddruckreihe / Standard pressure										<i>metr.</i>	<i>unc.</i>			
10.9																
350	1/2"	VFH 3001	31,0	24,3	38,1	54	17,5	46	13	6,2	8,75	M 8x25	5/16 x 1 1/4	0,15		
350	3/4"	VFH 3002	38,9	32,2	47,6	65	22,3	52	14	6,2	10,75	M 10x30	3/8 x 1 1/4	0,17		
320	1"	VFH 3003	45,3	38,5	52,4	70	26,2	59	16	7,5	10,75	M 10x30	3/8 x 1 1/4	0,22		
280	1 1/4"	VFH 3004	51,6	43,7	58,7	79	30,2	73	16	7,5	12,00	M 10x30	7/16 x 1 1/2	0,30		
210	1 1/2"	VFH 3005	61,1	50,8	69,9	94	35,7	83	16	7,5	13,50	M 12x35	1/2 x 1 1/2	0,45		
210	2"	VFH 3006	72,3	62,8	77,8	102	42,9	97	16	9,0	13,50	M 12x35	1/2 x 1 1/2	0,50		
Schraube Festigkeitskl.		Hochdruckreihe / High pressure										<i>metr.</i>	<i>unc.</i>			
10.9																
420	1/2"	VFH 6001	32,5	24,6	40,5	56	18,2	48	16	7,2	8,75	M 8x30	5/16 x 1 1/4	0,16		
420	3/4"	VFH 6002	42,0	32,5	50,8	71	23,8	60	20	8,2	10,75	M 10x35	3/8 x 1 1/2	0,35		
420	1"	VFH 6003	48,4	38,8	57,2	81	27,8	70	25	9,0	13,00	M 12x45	–	0,53		
420	1 1/4"	VFH 6004	54,8	44,5	66,6	95	31,8	78	27	9,8	14,75	M 14x50	1/2 x 1 3/4	0,80		
420	1 1/2"	VFH 6005	64,3	51,6	79,3	113	36,5	95	30	12,0	17,00	M 16x55	5/8 x 2	1,35		
420	2"	VFH 6006	80,2	67,6	96,8	133	44,5	114	37	12,0	21,00	M 20x70	3/4 x 2 1/2	2,10		

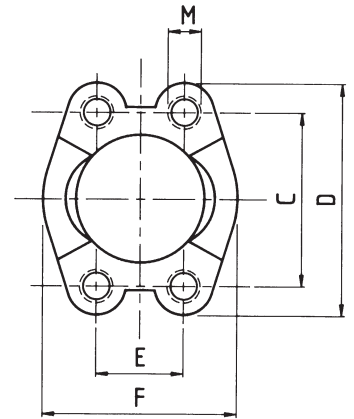
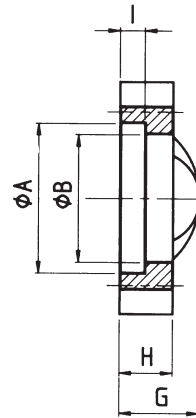

Bestellbezeichnung: ordering code:	S355J2^{*1} C45	1.4404^{*1} 316L
• nur Flansch flange only	VFG-...	VFG-X-...

maximaler Betriebsdruck maximum recommended working pressure	S.A.E. Baugröße nominal flange size	Typ type	Abmessungen dimensions										Gewicht weight
			A	B	C	D	E	F	G	H	I	M	
kg/cm ²	inch												
Schraube Festigkeitskl.			Standarddruckreihe / Standard pressure										
10.9													
350	1/2"	VFG 3001	31,0	24,3	38,1	54	17,5	46	19	13	6,2	M 8	0,15
350	3/4"	VFG 3002	38,9	32,2	47,6	65	22,3	52	22	14	6,2	M 10	0,17
320	1"	VFG 3003	45,3	38,5	52,4	70	26,2	59	24	16	7,5	M 10	0,22
280	1 1/4"	VFG 3004	51,6	43,7	58,7	79	30,2	73	22	14	7,5	M 10	0,30
210	1 1/2"	VFG 3005	61,1	50,8	69,9	94	35,7	83	25	16	7,5	M 12	0,45
210	2"	VFG 3006	72,3	62,8	77,8	102	42,9	97	26	16	9,0	M 12	0,50
175	2 1/2"	VFG 3007	84,9	74,9	88,9	114	50,8	109	38	19	9,0	M 12	0,88
175	2 1/2"	VFG 3007-B 76,6	84,9	76,6	88,9	114	50,8	109	38	19	9,0	M 12	0,88
160	3"	VFG 3008	102,4	90,9	106,4	135	61,9	131	41	22	9,0	M 16	1,30
35	3 1/2"	VFG 3009	115,1	102,4	120,7	152	69,9	140	28	22	10,7	M 16	1,29
35	4"	VFG 3010	127,8	115,0	130,2	162	77,8	152	35	25	10,7	M 16	1,65
35	5"	VFG 3011	153,2	140,5	152,4	184	92,1	181	41	28	10,7	M 16	2,50
Schraube Festigkeitskl.			Hochdruckreihe / High pressure										
10.9													
420	1/2"	VFG 6001	32,5	24,6	40,5	56	18,2	48	22	16	7,2	M 8	0,16
420	3/4"	VFG 6002	42,0	32,5	50,8	71	23,8	60	28	19	8,2	M 10	0,35
420	1"	VFG 6003	48,4	38,8	57,2	81	27,8	70	33	24	9,0	M 12	0,53
420	1 1/4"	VFG 6004	54,8	44,5	66,6	95	31,8	78	38	27	9,8	M 14	0,80
420	1 1/4"	VFG 6004-M12	54,8	44,5	66,6	95	31,8	78	38	27	9,8	M 12	0,80
420	1 1/2"	VFG 6005	64,3	51,6	79,3	113	36,5	95	43	30	12,0	M 16	1,35
420	2"	VFG 6006	80,2	67,6	96,8	133	44,5	114	52	37	12,0	M 20	2,10
420	2 1/2"	VFG 6007	108,9	90,5	123,8	180	58,8	152	45	45	20,5	M 24	4,10
420	3"	VFG 6008	132,5	115,5	152,4	215	71,6	198	55	55	25,5	M 30	8,60

Oberfläche: CR-6: auslaufend/Neu: CR-6 frei / surface: CR-6: phase-out/New: CR-6 free

*1 oder vergleichbare Güte / or comparable material

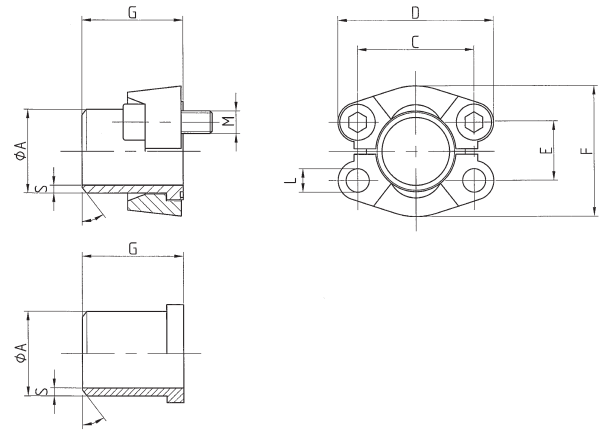

Bestellbezeichnung: ordering code:	S355J2^{*1}	1.4404^{*1} 316L
• nur Anschweißbund flange head only	SFS-...	SFX-...
• Anschweißflansch mit Zubehör incl. Flanschhälften (oder Vollflansch), metrischem Schraubensatz und O-Ring butt weld flange with accessories including split flanges (or complete flange), metric bolts and o-ring	SFS-...M	SFX-...MX
• Anschweißflansch mit Zubehör incl. Flanschhälften (oder Vollflansch), UNC-Schraubensatz und O-Ring including split flanges (or complete flange), UNC-bolts and o-ring	SFS-...U	SFX-...UX
Bestellbezeichnung für Anschweißbund in Gegenflanschausführung (ohne O-Ringnut): Ordering code flange head as counterflange (without o-ring groove).		
• nur Anschweißbund ohne Nut flange head without o-ring groove	GSFS-...	GSFX-...

* Der angeführte maximale Betriebsdruck ist bezogen auf den Flansch! Der tatsächliche Betriebsdruck wird bestimmt durch das Rohr (Wandstärke) sowie die Güte des Rohres!
The maximum recommended working pressure is based on the flange. The working pressure of the system is determined by the tube (thickness) and by the steel quality of the tube!

** bitte angeben:
M10 oder M12 Schrauben
please state:
bolts M10 or M12

maximaler Betriebsdruck* maximum recommended working pressure	S.A.E. Baugröße nominal flange size	Typ type	Abmessungen dimensions							Schrauben bolts		Gewicht weight
			C	D	E	F	G	L	M	kg		
kg/cm ²	inch											
Schraube Festigkeitskl. 10.9	Standarddruckreihe / Standard pressure										metr.	unc.
350	1/2"	SFS 3001	38,1	54	17,5	45,6	41	8,50	M 8x25	5/16 x 1 1/4	0,08	
			A x S = 16 x 2 – 20 x 2,5 – 21,3 x 2,9 – 21,3 x 3,8 – 21,3 x 4,7									
350	3/4"	SFS 3002	47,6	65	22,3	51,8	50	10,50	M 10x30	3/8 x 1 1/4	0,16	
			A x S = 25 x 3 – 26,9 x 3,6 – 26,9 x 3,9									
320	1"	SFS 3003	52,4	70	26,2	58,4	50	10,50	M 10x30	3/8 x 1 1/4	0,23	
			A x S = 25 x 3 – 28 x 3 – 30 x 3 – 30 x 4 – 33,7 x 4,5 – 38 x 4 – 38 x 5									
280	1 1/4"	SFS 3004	58,7	79	30,2	72,6	55	10,50 12,75	M 10x30** M 12x35	7/16 x 1 1/2	0,30	
			A x S = 25 x 3 – 30 x 3 – 38 x 3 – 38 x 4 – 38 x 5 – 42,4 x 3,6 – 42,4 x 4,5 – 42,4 x 6,3									
210	1 1/2"	SFS 3005	69,9	94	35,7	82,2	57	13,30	M 12x35	1/2 x 1 1/2	0,40	
			A x S = 38 x 4 – 42 x 3 – 42 x 5 – 45 x 5 – 48,3 x 2,6 – 48,3 x 3,6 – 48,3 x 5 – 48,3 x 6,3 – 48,3 x 7,1 – 50 x 6									
210	2"	SFS 3006	77,8	102	42,9	96,4	57	13,30	M 12x35	1/2 x 1 1/2	0,50	
			A x S = 48,3 x 5 – 55 x 5 – 60,3 x 2,9 – 60,3 x 3,9 – 60,3 x 5 – 60,3 x 6,3 – 60,3 x 8									
175	2 1/2"	SFS 3007	88,9	114	50,8	108,2	58	13,30	M 12x40	1/2 x 1 3/4	0,80	
			A=74: A x S = 65 x 6 – 70 x 7,5 – 76,1 x 5,5 (74 x 4,5) ^{*2} – 76,1 x 7,1 (74 x 6,1) ^{*2}									
			A=76,1: A x S = 76,1 x 5,5 ^{*2} – 76,1 x 7,1 ^{*2}									
160	3"	SFS 3008	106,4	135	61,9	130,6	58	17,00	M 16x50	5/8 x 2	1,10	
			A x S = 80 x 6 – 88,9 x 3,2 – 88,9 x 3,9 – 88,9 x 7 – 88,9 x 8									
35	3 1/2"	SFS 3009	120,7	152	69,9	139,0	60	17,00	M 16x50	5/8 x 2	1,40	
			A x S = 100 x 6 – 88,9 x 3,6 – 88,9 x 8									
35	4"	SFS 3010	130,2	162	77,8	152,0	60	17,00	M 16x50	5/8 x 2	1,75	
			A x S = 110 x 6 – 114,3 x 3,6 – 114,3 x 6,02 – 114,3 x 8,8									
35	5"	SFS 3011	152,4	184	92,1	180,0	60	17,00	M 16x55	5/8 x 2	2,62	
			A x S = 133 x 6,5 – 139,7 x 4 – 139,7 x 10									

*1 oder vergleichbare Güte / or comparable material

*2 Rohrdurchmesser 76,1 gemäß ISO 6162 max. 74 mm / Pipe diameter 76.1 according to ISO 6162 max. 74 mm

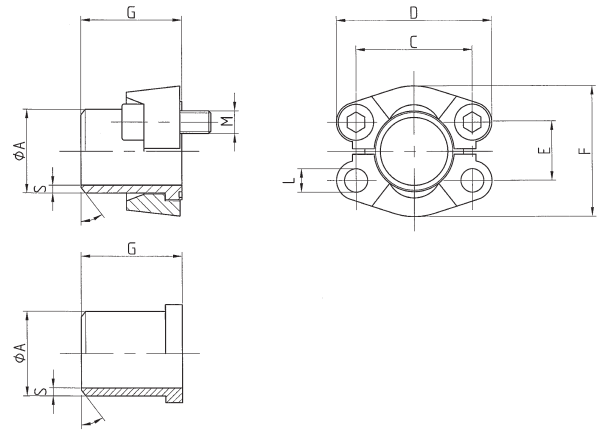

Bestellbezeichnung: ordering code:	S355J2 *1	1.4404 *1
		316L
• nur Anschweißbund flange head only	SFS-...	SFX-...
• Anschweißflansch mit Zubehör incl. Flanschkhälften (oder Vollflansch), metrischem Schraubensatz und O-Ring butt weld flange with accessories including split flanges (or complete flange), metric bolts and o-ring	SFS-...M	SFX-...MX
• Anschweißflansch mit Zubehör incl. Flanschkhälften (oder Vollflansch), UNC-Schraubensatz und O-Ring including split flanges (or complete flange), UNC-bolts and o-ring	SFS-...U	SFX-...UX
Bestellbezeichnung für Anschweißbund in Gegenlanschausführung (ohne O-Ringnut): Ordering code flange head as counterflange (without o-ring groove).		
• nur Anschweißbund ohne Nut flange head without o-ring groove	GSFS-...	GSFX-...

* Der angeführte maximale Betriebsdruck ist bezogen auf den Flansch! Der tatsächliche Betriebsdruck wird bestimmt durch das Rohr (Wandstärke) sowie die Güte des Rohres!
The maximum recommended working pressure is based on the flange. The working pressure of the system is determined by the tube (thickness) and by the steel quality of the tube!

maximaler Betriebsdruck* maximum recommended working pressure	S.A.E. Baugröße nominal flange size	Typ type	Abmessungen dimensions						Schrauben bolts		Gewicht weight	
			C	D	E	F	G	L	M	kg		
kg/cm ²	inch											
Schraube Festigkeitskl. 10.9	Hochdruckreihe / High pressure									metr.	unc.	
420	1/2"	SFS 6001	40,5	56	18,2	47,2	34	8,50	M 8x30	5/16 x 1 1/4	0,08	
			A x S = 16 x 2 – 20 x 2,5 – 21,3 x 3,8 – 21,3 x 4,5									
420	3/4"	SFS 6002	50,8	71	23,8	60,0	38	10,50	M 10x35	3/8 x 1 1/2	0,17	
			A x S = 16 x 2 – 20 x 2,5 – 25 x 3 – 25 x 3,5 – 25 x 4 – 26,9 x 5,6									
420	1"	SFS 6003	57,2	81	27,8	69,6	40	13,30/12	M 12x45	7/16 x 1 3/4	0,25	
			A x S = 25 x 3 – 30 x 3 – 30 x 4 – 33,7 x 6,3 – 33,7 x 7,1 – 38 x 4 – 38 x 5									
420	1 1/4"	SFS 6004	66,6	95	31,8	77,2	45	13,30/14,60	M 12x45 M 14x50	1/2 x 1 3/4	0,30	
			A x S = 25 x 3 – 30 x 4 – 38 x 4 – 38 x 5 – 38 x 5,5 – 38 x 6 – 42,4 x 6,3									
420	1 1/2"	SFS 6005	79,3	113	36,5	95,0	50	16,80	M 16x55	5/8 x 2	0,53	
			A x S = 38 x 5 – 45 x 6,5 – 48,3 x 5 – 48,3 x 6,3 – 48,3 x 7,1 – 48,3 x 8 – 48,3 x 8,8 – 50 x 6									
420	2"	SFS 6006	96,8	133	44,5	113,8	58	21/20	M 20x70	3/4 x 2 1/2	0,90	
			A x S = 48,3 x 6,3 – 60,3 x 6,3 – 60,3 x 7,5 – 60,3 x 8 – 60,3 x 8,75 – 60,3 x 10 – 60,3 x 13,4 – 65x8									
420	2 1/2"	SFS 6007	123,8	180	58,8	150,2	75	26,00	M 24x80	–	2,40	
			A x S = 76,1 x 8 – 76,1 x 10 – 76,1 x 12,5 – 88,9 x 10 – 88,9 x 11,1 – 88,9 x 14,2 – 88,9 x 17									
420	3"	SFS 6008	152,4	215	71,6	198,2	80	32,00	M 30x90	–	3,60	
			A x S = 88,9 x 10 – 88,9 x 11,1 – 88,9 x 14,2 – 114,3 x 11 – 114,3 x 17,5									

*1 oder vergleichbare Güte / or comparable material

*2 Rohrdurchmesser 76,1 gemäß ISO 6162 max. 74 mm / Pipe diameter 76.1 according to ISO 6162 max. 74 mm

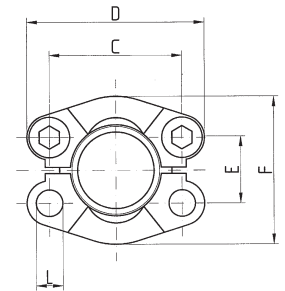
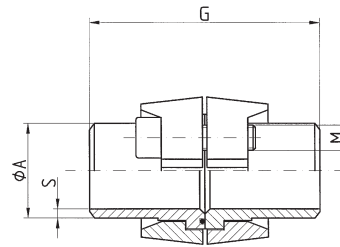

Bestellbezeichnung: ordering code:	S355J2^{*1}	1.4404^{*1} 316L
• Anschweißdoppelflansch welding head-coupling	DSFS	DSFX

* Der angeführte maximale Betriebsdruck ist bezogen auf den Flansch! Der tatsächliche Betriebsdruck wird bestimmt durch das Rohr (Wandstärke) sowie die Güte des Rohres!
The maximum recommended working pressure is based on the flange. The working pressure of the system is determined by the tube (thickness) and by the steel quality of the tube!

** bitte angeben:
M10 oder M12 Schrauben
please state:
bolts M10 or M12

maximaler Betriebsdruck* maximum recommended working pressure	S.A.E. Baugröße nominal flange size	Typ type	Abmessungen dimensions						Schrauben bolts		Gewicht weight	
			C	D	E	F	G	L	M	kg		
kg/cm ²	inch											
Schraube Festigkeitskl.			Standarddruckreihe / Standard pressure							<i>metr.</i>	<i>unc.</i>	
10,9												
350	1/2"	DSFS 3001	38,1	54	17,5	45,6	82	8,50	M 8x30	5/16 x 1 1/4	0,50	
			A x S = 16 x 2 – 20 x 2,5 – 21,3 x 2,9 – 21,3 x 3,8 – 21,3 x 4,7									
350	3/4"	DSFS 3002	47,6	65	22,3	51,8	100	10,50	M 10x30	3/8 x 1 1/4	0,80	
			A x S = 25 x 3 – 26,9 x 3,6 – 26,9 x 3,9									
320	1"	DSFS 3003	52,4	70	26,2	58,4	100	10,50	M 10x35	3/8 x 1 1/4	1,10	
			A x S = 25 x 3 – 30 x 3 – 30 x 4 – 33,7 x 4,5 – 38 x 4 – 38 x 5									
280	1 1/4"	DSFS 3004	58,7	79	30,2	72,6	110	10,50 12,75/12,00	M 10x35** M 12x40	7/16 x 1 1/2	1,50	
			A x S = 25 x 3 – 30 x 3 – 38 x 3 – 38 x 4 – 38 x 5 – 42,4 x 3,6 – 42,4 x 4,5 – 42,4 x 6,3									
210	1 1/2"	DSFS 3005	69,9	94	35,7	82,2	114	13,30	M 12x35	1/2 x 1 1/2	2,20	
			A x S = 38 x 4 – 42 x 3 – 42 x 5 – 45 x 5 – 48,3 x 2,6 – 48,3 x 3,6 – 48,3 x 5 – 48,3 x 6,3 – 48,3 x 7,1 – 50 x 6									
210	2"	DSFS 3006	77,8	102	42,9	96,4	114	13,30	M 12x35	1/2 x 1 1/2	2,40	
			A x S = 48,3 x 5 – 55 x 5 – 60,3 x 2,9 – 60,3 x 3,9 – 60,3 x 5 – 60,3 x 6,3 – 60,3 x 8									
175	2 1/2"	DSFS 3007	88,9	114	50,8	108,2	116	13,30	M 12x45	1/2 x 1 3/4	3,50	
			A=74: A x S = 65 x 6 – 70 x 7,5 – 76,1 x 5,5 (74 x 4,5) ^{*2} – 76,1 x 7,1 (74 x 6,1) ^{*2}									
			A=76,1: A x S = 76,1 x 5,5 ^{*2} – 76,1 x 7,1 ^{*2}									
160	3"	DSFS 3008	106,4	135	61,9	130,6	116	17,00	M 16x50	5/8 x 2	5,30	
			A x S = 80 x 6 – 88,9 x 3,2 – 88,9 x 3,6 – 88,9 x 7 – 88,9 x 8									
35	3 1/2"	DSFS 3009	120,7	152	69,9	139,0	120	17,00	M 16x50	5/8 x 2	5,30	
			A x S = 100 x 6 – 88,9 x 3,6 – 88,9 x 8									
35	4"	DSFS 3010	130,2	162	77,8	152,0	120	17,00	M 16x55	5/8 x 2	7,50	
			A x S = 110 x 6 – 114,3 x 3,6 – 114,3 x 6,02 – 114,3 x 8,8									
35	5"	DSFS 3011	152,4	184	92,1	180,0	120	17,00	M 16x60	5/8 x 2	11,0	
			A x S = 133 x 6,5 – 139,7 x 4 – 139,7 x 10									

*1 oder vergleichbare Güte / or comparable material

*2 Rohrdurchmesser 76,1 gemäß ISO 6162 max. 74 mm / Pipe diameter 76.1 according to ISO 6162 max. 74 mm

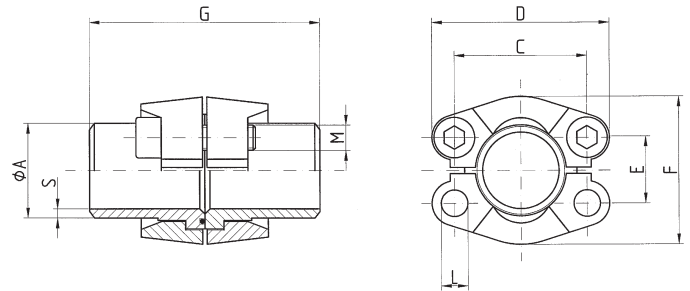

Bestellbezeichnung: ordering code:	S355J2^{*1}	1.4404^{*1} 316L
• Anschweißdoppelflansch welding head-coupling	DSFS	DSFX

* Der angeführte maximale Betriebsdruck ist bezogen auf den Flansch! Der tatsächliche Betriebsdruck wird bestimmt durch das Rohr (Wandstärke) sowie die Güte des Rohres!
The maximum recommended working pressure is based on the flange. The working pressure of the system is determined by the tube (thickness) and by the steel quality of the tube!

maximaler Betriebsdruck* maximum recommended working pressure	S.A.E. Baugröße nominal flange size	Typ type	Abmessungen dimensions						Schrauben bolts		Gewicht weight
			C	D	E	F	G	L	M	kg	
kg/cm ²	inch										
Schraube Festigkeitskl. 10.9	Hochdruckreihe / High pressure								metr.	unc.	
420	1/2"	DSFS 6001	40,5	56	18,2	47,2	68	8,50	M 8x35	5/16 x 1 1/4	0,60
			A x S = 16 x 2 – 20 x 2,5 – 21,3 x 3,8 – 21,3 x 4,5								
420	3/4"	DSFS 6002	50,8	71	23,8	60,0	76	10,50	M 10x40	3/8 x 1 1/2	1,10
			A x S = 16 x 2 – 20 x 2,5 – 25 x 3 – 25 x 3,5 – 25 x 4 – 26,9 x 5,6								
420	1"	DSFS 6003	57,2	81	27,8	69,6	80	13,30/12,00	M 12x50	7/16 x 1 3/4	1,70
			A x S = 25 x 3 – 30 x 3 – 30 x 4 – 33,7 x 6,3 – 33,7 x 7,1 – 38 x 4 – 38 x 5								
420	1 1/4"	DSFS 6004	66,6	95	31,8	77,2	90	13,30/14,60	M 12x50 M 14x55	1/2 x 1 3/4	2,50
			A x S = 25 x 3 – 30 x 4 – 38 x 4 – 38 x 5 – 38 x 5,5 – 38 x 6 – 42,4 x 6,3								
420	1 1/2"	DSFS 6005	79,3	113	36,5	95,0	100	16,80	M 16x60	5/8 x 2	4,10
			A x S = 38 x 5 – 45 x 6,5 – 48,3 x 5 – 48,3 x 6,3 – 48,3 x 7,1 – 48,3 x 8 – 48,3 x 8,8 – 50 x 6								
420	2"	DSFS 6006	96,8	133	44,5	113,8	116	21/20	M 20x75	3/4 x 2 1/2	6,70
			A x S = 48,3 x 6,3 – 60,3 x 6,3 – 60,3 x 7,5 – 60,3 x 8 – 60,3 x 8,75 – 60,3 x 10 – 60,3 x 13,4 – 65 x 8								
420	2 1/2"	DSFS 6007	123,8	180	58,8	150,2	150	26,00	M 24x90	–	15,0
			A x S = 76,1 x 8 – 76,1 x 10 – 76,1 x 12,5 – 88,9 x 10 – 88,9 x 11 – 88,9 x 14,2 – 88,9 x 17								
420	3"	DSFS 6008	152,4	215	71,6	198,2	160	32,00	M 30x110	–	27,0
			A x S = 88,9 x 10 – 88,9 x 11 – 88,9 x 14,2 – 114,3 x 11 – 114,3 x 17,5								

*1 oder vergleichbare Güte / or comparable material

*2 Rohrdurchmesser 76,1 gemäß ISO 6162 max. 74 mm / Pipe diameter 76.1 according to ISO 6162 max. 74 mm

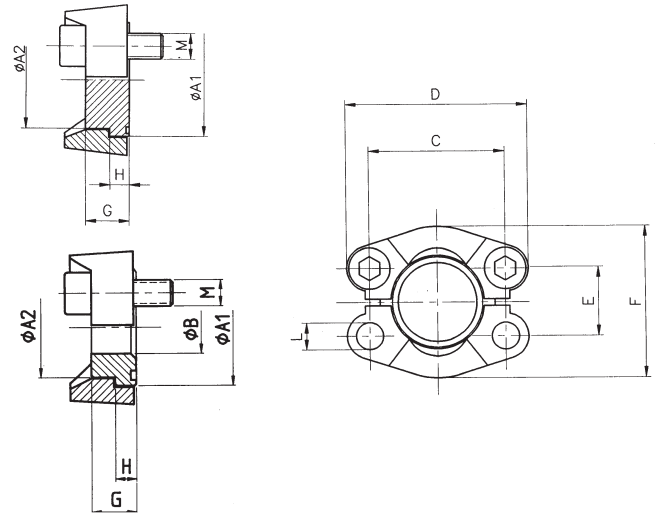

Bestellbezeichnung: ordering code:	S355J2^{*1}	1.4404^{*1} 316L
• nur Flanschbund flange head only	FT-...	FT-X-...
• incl. Flanschhälften (oder Vollflansch), metrischem Schraubensatz und O-Ring including split flanges (or complete flange), metric bolts and o-ring	FT-...M	FT-X-...MX
• incl. Flanschhälften (oder Vollflansch), UNC-Schraubensatz und O-Ring including split flanges (or complete flange), UNC bolts and o-ring	FT-...U	FT-X-...UX

maximaler Betriebsdruck maximum recommended working pressure	S.A.E. Baugröße nominal flange size	Typ type	Abmessungen dimensions											Schrauben bolts		Gewicht (nur Bund) weight (plug only)	
			A1	A2	B	C	D	E	F	G	H	L	M	kg			
kg/cm ²	inch																
Schraube Festigkeitskl. 10.9	Standarddruckreihe / Standard pressure														metr.	unc.	
350	1/2"	FT 3001 (BO)	30,2	24,0	0/10	38,1	54	17,5	46	16	6,8	8,5	M 8x25	5/8 x 1 1/4	0,05		
350	3/4"	FT 3002 (BO)	38,1	31,8	0/15	47,6	65	22,3	52	17	6,8	10,5	M 10x30	3/8 x 1 1/4	0,08		
320	1"	FT 3003 (BO)	44,5	38,0	0/20	52,4	70	26,2	59	17	8,0	10,5	M 10x30	3/8 x 1 1/2	0,12		
280	1 1/4"	FT 3004 (BO)	50,8	43,0	0/27	58,7	79	30,2	73	17	8,0	*2	*3	7/16 x 1 1/2	0,13		
210	1 1/2"	FT 3005 (BO)	60,3	50,0	0/32	69,9	94	35,7	83	19	8,0	13,3	M 12x35	1/2 x 1 1/2	0,20		
210	2"	FT 3006 (BO)	71,4	62,0	0/40	77,8	102	42,9	97	19	9,6	13,3	M 12x35	1/2 x 1 1/2	0,31		
175	2 1/2"	FT 3007 (BO)	84,1	74,0	0/50	88,9	114	50,8	109	30	9,6	13,3	M 12x40	1/2 x 1 3/4	0,47		
Schraube Festigkeitskl. 10.9	Hochdruckreihe / High pressure														metr.	unc.	
420	1/2"	FT 6001 (BO)	31,8	24,0	0/10	40,5	56	18,2	48	16	7,8	8,5	M 8x30	5/8 x 1 1/4	0,06		
420	3/4"	FT 6002 (BO)	41,3	31,8	0/15	50,8	71	23,8	60	20	8,8	10,5	M 10x35	3/8 x 1 1/4	0,12		
420	1"	FT 6003 (BO)	47,6	38,0	0/20	57,2	81	27,8	70	22	9,5	*4	M 12x45	7/16 x 1 3/4	0,17		
420	1 1/4"	FT 6004 (BO)	54,0	44,0	0/27	66,6	95	31,8	78	27	10,3	*5	M 14x50	1/2 x 1 3/4	0,22		
420	1 1/2"	FT 6005 (BO)	63,5	50,8	0/32	79,3	113	36,5	95	32	12,6	16,8	M 16x55	5/8 x 2	0,39		
420	2"	FT 6006 (BO)	79,4	67,0	0/40	96,8	133	44,5	114	40	12,6	21,00	M 20x70	3/4 x 2 1/2	0,79		

*1 oder vergleichbare Güte / or comparable material

*2 wahlweise 10,5, 12,00 oder 12,75 / choice of 10.5, 12.00 or 12.75

*3 wahlweise M 10x30 oder M 12x35 / choice of M 10x30 or M 12x35

*4 wahlweise 12,0 oder 13,3 / choice of 12.0 or 13.3

*5 wahlweise 13,3 oder 14,6 / choice of 13.3 or 14.6

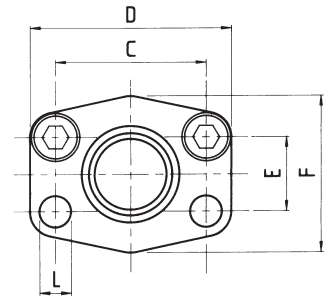
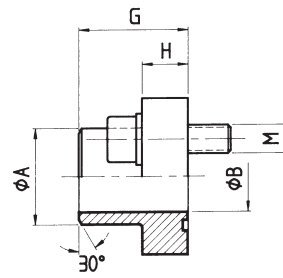

Bestellbezeichnung: ordering code:	S355J2^{*1}	1.4404^{*1} 316L
• nur Flansch flange only	AFS-...ST	AFX-...ST
• incl. metrischem Schraubensatz und O-Ring including metric bolts and o-ring	AFS-...STM	AFX-...STMX
• incl. UNC-Schraubensatz und O-Ring including UNC bolts and o-ring	AFS-...STU	AFX-...STUX

* Der angeführte maximale Betriebsdruck ist bezogen auf den Flansch! Der tatsächliche Betriebsdruck wird bestimmt durch das Rohr (Wandstärke) sowie die Güte des Rohres!
The maximum recommended working pressure is based on the flange. The working pressure of the system is determined by the tube (thickness) and by the steel quality of the tube!

maximaler Betriebsdruck * maximum recommended working pressure	S.A.E. Baugröße nominal flange size	Typ type	Abmessungen dimensions									Schrauben bolts		Gewicht weight	
			A	B	C	D	E	F	G	H	L	M	kg		
kg/cm ²	inch														
Schraube Festigkeitskl. 10.9		Standarddruckreihe / Standard pressure											metr.	unc.	
350	1/2"	AFS 080 ST	21,5	13,0	38,1	54	17,5	46	36	16	9,0	M 8x30	5/16 x 1 1/4	0,28	
350	1/2"	AFS 080 ST-038	17,5	10,0	38,1	54	17,5	46	36	16	9,0	M 8x30	5/16 x 1 1/4	0,25	
350	3/4"	AFS 100 ST	28,0	19,0	47,6	65	22,3	50	36	18	11,0	M 10x35	3/8 x 1 1/2	0,39	
320	1"	AFS 102 ST	34,0	25,0	52,4	70	26,2	55	38	18	11,0	M 10x35	3/8 x 1 1/2	0,46	
280	1 1/4"	AFS 104 ST	42,8	32,0	58,7	79	30,2	68	41	21	11,5	M 10x40	7/16 x 1 1/2	0,66	
210	1 1/2"	AFS 106 ST	48,6	38,0	69,9	93	35,7	78	44	25	13,5	M 12x45	1/2 x 1 3/4	1,05	
210	2"	AFS 108 ST	61,0	51,0	77,8	102	42,9	90	45	25	13,5	M 12x45	1/2 x 1 3/4	1,19	
175	2 1/2"	AFS 110 ST	77,0	63,0	88,9	114	50,8	105	50	25	13,5	M 12x45	1/2 x 1 3/4	1,40	
160	3"	AFS 112 ST	92,0	73,0	106,4	134	61,9	124	50	27	17,5	M 16x50	5/8 x 2	2,15	
35	3 1/2"	AFS 114 ST	103,0	89,0	120,7	152	69,9	136	48	27	17,5	M 16x50	5/8 x 2	2,40	
35	4"	AFS 116 ST	115,5	99,0	130,2	162	77,8	146	48	27	17,5	M 16x50	5/8 x 2	2,85	
35	5"	AFS 118 ST	142,0	120,0	152,4	184	92,1	180	50	28	17,5	M 16x55	5/8 x 2	5,20	
Schraube Festigkeitskl. 10.9		Hochdruckreihe / High pressure											metr.	unc.	
420	1/2"	AFS 401 ST-012	21,5	13,0	40,5	54	18,2	46	36	16	9,0	M 8x30	5/16 x 1 1/4	0,29	
420	1/2"	AFS 401 ST-038	17,5	10,0	40,5	54	18,2	46	36	16	9,0	M 8x30	5/16 x 1 1/4	0,26	
420	3/4"	AFS 402 ST	28,0	19,0	50,8	71	23,8	55	35	21	11,0	M 10x35	3/8 x 1 1/2	0,50	
420	1"	AFS 403 ST	34,0	25,0	57,2	79	27,8	68	41	21	13,0	M 12x45	7/16 x 1 3/4	0,76	
375	1 1/4"	AFS 404 ST	42,8	32,0	66,6	93	31,8	78	44	25	15,0	M 14x50	–	1,20	
375	1 1/4"	AFS 404 STL=13,5	42,8	32,0	66,6	93	31,8	78	44	25	13,5	M 12x45	1/2 x 1 3/4	1,20	
250	1 1/2"	AFS 405 ST	48,6	38,0	79,3	112	36,5	94	55	30	17,0	M 16x50	5/8 x 2	1,65	
250	2"	AFS 406 ST	61,0	51,0	96,8	134	44,5	114	65	37	21,0	M 20x70	3/4 x 2 1/2	2,45	
420	2 1/2"	AFS 407 ST 76	76,1	51,0	123,8	180	58,8	152	80	45	26,0	M 24x80	–	6,40	
420	2 1/2"	AFS 407 ST 88	90,0	60,5	123,8	180	58,8	152	80	45	26,0	M 24x80	–	8,30	

*1 oder vergleichbare Güte / or comparable material

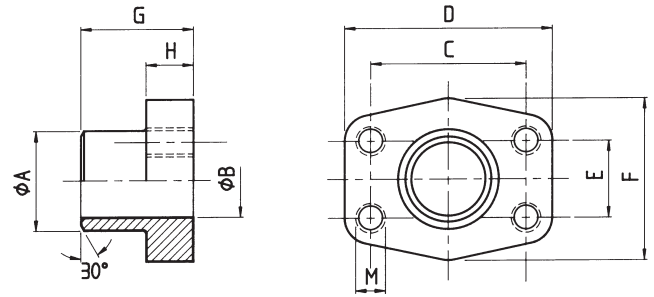

Bestellbezeichnung: ordering code:	S355J2^{*1}	1.4404^{*1} 316L
• Flansch mit metrischen Gewinden flange with metric threads	GFS-...ST	GFX-...ST
• Flansch mit UNC-Gewinden flange with UNC threads	GFS-...STU	GFX-...STU

* Der angeführte maximale Betriebsdruck ist bezogen auf den Flansch! Der tatsächliche Betriebsdruck wird bestimmt durch das Rohr (Wandstärke) sowie die Güte des Rohres!
The maximum recommended working pressure is based on the flange. The working pressure of the system is determined by the tube (thickness) and by the steel quality of the tube!

maximaler Betriebsdruck * maximum recommended working pressure	S.A.E. Baugröße nominal flange size	Typ type	Abmessungen dimensions								Gewinde thread		Gewicht weight	
			A	B	C	D	E	F	G	H	M			kg
kg/cm ²	inch													
Schraube Festigkeitskl.		Standarddruckreihe / Standard pressure										<i>metr.</i>	<i>unc.</i>	
10.9														
350	1/2"	GFS 080 ST	21,5	13,0	38,1	54	17,5	46	36	16	M 8	5/16	0,25	
350	1/2"	GFS 080 ST-038	17,5	10,0	38,1	54	17,5	46	36	16	M 8	5/16	0,28	
350	3/4"	GFS 100 ST	28,0	19,0	47,6	65	22,3	50	36	18	M 10	3/8	0,39	
320	1"	GFS 102 ST	34,0	25,0	52,4	70	26,2	55	38	18	M 10	3/8	0,46	
280	1 1/4"	GFS 104 ST	42,8	32,0	58,7	79	30,2	68	41	21	M 10	7/16	0,66	
210	1 1/2"	GFS 106 ST	48,6	38,0	69,9	93	35,7	78	44	25	M 12	1/2	1,05	
210	2"	GFS 108 ST	61,0	51,0	77,8	102	42,9	90	45	25	M 12	1/2	1,19	
175	2 1/2"	GFS 110 ST	77,0	63,0	88,9	114	50,8	105	50	25	M 12	1/2	1,40	
160	3"	GFS 112 ST	92,0	73,0	106,4	134	61,9	124	50	27	M 16	5/8	2,15	
35	3 1/2"	GFS 114 ST	103,0	89,0	120,7	152	69,9	136	48	27	M 16	5/8	2,40	
35	4"	GFS 116 ST	115,5	99,0	130,2	162	77,8	146	48	27	M 16	5/8	2,85	
35	5"	GFS 118 ST	142,0	120,0	152,4	184	92,1	180	50	28	M 16	5/8	5,20	
Schraube Festigkeitskl.		Hochdruckreihe / High pressure										<i>metr.</i>	<i>unc.</i>	
10.9														
420	1/2"	GFS 401 ST-012	21,5	13,0	40,5	54	18,2	46	36	16	M 8	5/16	0,26	
420	1/2"	GFS 401 ST-038	17,5	10,0	40,5	54	18,2	46	36	16	M 8	5/16	0,29	
420	3/4"	GFS 402 ST	28,0	19,0	50,8	71	23,8	55	35	21	M 10	3/8	0,50	
420	1"	GFS 403 ST	34,0	25,0	57,2	79	27,8	68	41	21	M 12	7/16	0,76	
375	1 1/4"	GFS 404 ST	42,8	32,0	66,6	93	31,8	78	44	25	M 14	–	1,20	
375	1 1/4"	GFS 404 ST-M12	42,8	32,0	66,6	93	31,8	78	44	25	M 12	1/2	1,05	
250	1 1/2"	GFS 405 ST	48,6	38,0	79,3	112	36,5	94	55	30	M 16	5/8	1,65	
250	2"	GFS 406 ST	61,0	51,0	96,8	134	44,5	114	65	37	M 20	3/4	2,45	
420	2 1/2"	GFS 407 ST 76	76,1	51,0	123,8	180	58,8	152	80	45	M 24	–	6,40	
420	2 1/2"	GFS 407 ST 88	90,0	60,5	123,8	180	58,8	152	80	45	M 24	–	8,30	

*1 oder vergleichbare Güte / or comparable material

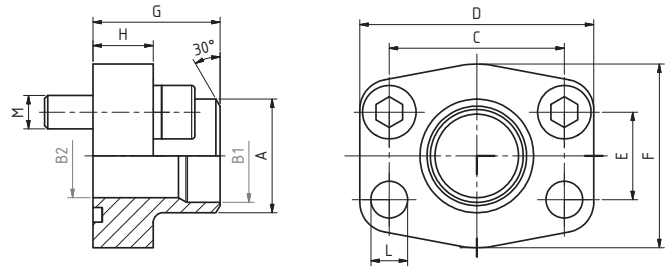

Bestellbezeichnung: ordering code:	S355J2^{*1}	1.4404^{*1} 316L
• nur Flansch flange only	AFS-...ST10	AFX-...ST10
• incl. metrischem Schraubensatz und O-Ring including metric bolts and o-ring	AFS-...ST10M	AFX-...ST10MX
• incl. UNC-Schraubensatz und O-Ring including unc bolts and o-ring	AFS-...ST10U	AFX-...ST10UX

* Der angeführte maximale Betriebsdruck ist bezogen auf den Flansch! Der tatsächliche Betriebsdruck wird bestimmt durch das Rohr (Wandstärke) sowie die Güte des Rohres!
The maximum recommended working pressure is based on the flange. The working pressure of the system is determined by the tube (thickness) and by the steel quality of the tube!

maximaler Betriebsdruck * maximum recommended working pressure	S.A.E. Baugröße nominal flange size	Typ type	Abmessungen dimensions											Schrauben bolts		Gewicht weight		
			Rohr/tube	A	B1	B2	C	D	E	F	G	H	L	M	kg			
kg/cm ²	inch																	
Schraube Festigkeitskl. 10.9	Standarddruckreihe / Standard pressure														metr.	unc.		
320	1"	AFS-102ST10	33,4x2,8	34,0	27,8	25,0	52,4	70	26,2	55	38	18	11,0	M10x35	3/8 x 1 1/2	0,40		
280	1 1/4"	AFS-104ST10	42,2x2,8	42,8	36,6	32,0	58,7	79	30,2	68	41	21	11,5	M10x40	7/16 x 1 1/2	0,61		
210	1 1/2"	AFS-106ST10	48,3x2,8	48,6	42,7	38,0	69,9	93	35,7	78	44	25	13,5	M12x45	1/2 x 1 3/4	0,96		
210	2"	AFS-108ST10	60,3x2,9	61,0	54,5	51,0	77,8	102	42,9	90	45	25	13,5	M12x45	1/2 x 1 3/4	1,11		
175	2 1/2"	AFS-110ST10	73x3	73,0	67,0	63,0	88,9	114	50,8	105	50	25	13,5	M12x45	1/2 x 1 3/4	1,51		
160	3"	AFS-112ST10	88,9x3	92,0	82,9	73,0	106,4	134	61,9	124	50	27	17,5	M16x50	5/8 x 2	2,19		
35	4"	AFS-116ST10	114,3x3	115,5	108,3	99,0	130,2	162	77,8	146	48	27	17,5	M16x50	5/8 x 2	2,77		
35	5"	AFS-118ST10	141,3x3,4	142,0	134,5	120,0	152,4	184	92,1	180	50	28	17,5	M16x55	5/8 x 2	3,85		

*1 oder vergleichbare Güte / or comparable material

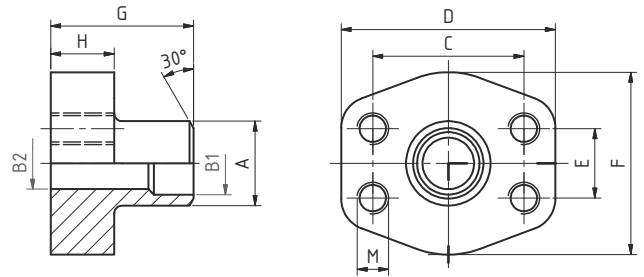

Bestellbezeichnung: ordering code:	S355J2^{*1}	1.4404^{*1} 316L
• Flansch mit metrischen Gewinden flange with metric threads	GFS-...ST10	GFX-...ST10
• Flansch mit UNC-Gewinden flange with unc threads	GFS-...ST10U	GFX-...ST10U

* Der angeführte maximale Betriebsdruck ist bezogen auf den Flansch! Der tatsächliche Betriebsdruck wird bestimmt durch das Rohr (Wandstärke) sowie die Güte des Rohres!
The maximum recommended working pressure is based on the flange. The working pressure of the system is determined by the tube (thickness) and by the steel quality of the tube!

maximaler Betriebsdruck * maximum recommended working pressure	S.A.E. Baugröße nominal flange size	Typ type	Abmessungen dimensions										Gewinde thread		Gewicht weight		
			Rohr/tube	A	B1	B2	C	D	E	F	G	H	M	kg			
kg/cm ²	inch																
Schraube Festigkeitskl. 10.9	Standarddruckreihe / Standard pressure													metr.	unc.		
320	1"	GFS-102ST10	33,4x2,8	34,0	27,8	25,0	52,4	70	26,2	55	38	18	M10	3/8-16	-		
280	1 1/4"	GFS-104ST10	42,2x2,8	42,8	36,6	32,0	58,7	79	30,2	68	41	21	M10	7/16-14	-		
210	1 1/2"	GFS-106ST10	48,3x2,8	48,6	42,7	38,0	69,9	93	35,7	78	44	25	M12	1/2-13	-		
210	2"	GFS-108ST10	60,3x2,9	61,0	54,5	51,0	77,8	102	42,9	90	45	25	M12	1/2-13	-		
175	2 1/2"	GFS-110ST10	73x3	73,0	67,0	63,0	88,9	114	50,8	105	50	25	M12	1/2-13	-		
160	3"	GFS-112ST10	88,9x3	92,0	82,9	73,0	106,4	134	61,9	124	50	27	M16	5/8-11	-		
35	4"	GFS-116ST10	114,3x3	115,5	108,3	99,0	130,2	162	77,8	146	48	27	M16	5/8-11	-		
35	5"	GFS-118ST10	141,3x3,4	142,0	134,5	120,0	152,4	184	92,1	180	50	28	M16	5/8-11	-		

*1 oder vergleichbare Güte / or comparable material

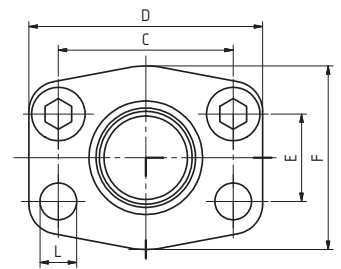
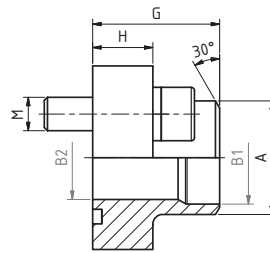

Bestellbezeichnung: ordering code:	S355J2^{*1}	1.4404^{*1} 316L
• nur Flansch flange only	AFS-...ST40	AFX-...ST40
• incl. metrischem Schraubensatz und O-Ring including metric bolts and o-ring	AFS-...ST40M	AFX-...ST40MX
• incl. UNC-Schraubensatz und O-Ring including unc bolts and o-ring	AFS-...ST40U	AFX-...ST40UX

* Der angeführte maximale Betriebsdruck ist bezogen auf den Flansch! Der tatsächliche Betriebsdruck wird bestimmt durch das Rohr (Wandstärke) sowie die Güte des Rohres!
The maximum recommended working pressure is based on the flange. The working pressure of the system is determined by the tube (thickness) and by the steel quality of the tube!

maximaler Betriebsdruck * maximum recommended working pressure	S.A.E. Baugröße nominal flange size	Typ type	Abmessungen dimensions											Schrauben bolts		Gewicht weight		
			Rohr/tube	A	B1	B2	C	D	E	F	G	H	L	M	kg			
kg/cm ²	inch																	
Schraube Festigkeitskl.		Standarddruckreihe / Standard pressure													metr.	unc.		
10.9																		
350	1/2"	AFS-080ST40	21,3x2,8	21,5	15,7	13,0	38,1	54	17,5	46	36	16	9,0	M8x30	5/16 x 1 1/4	0,24		
350	3/4"	AFS-100ST40	26,7x2,9	28,0	20,9	19,0	47,6	65	22,3	50	36	18	11,0	M10x35	3/8 x 1 1/2	0,35		
320	1"	AFS-102ST40	33,4x3,4	34,0	26,6	25,0	52,4	70	26,2	55	38	18	11,0	M10x35	3/8 x 1 1/2	0,41		
280	1 1/4"	AFS-104ST40	42,4x3,6	42,8	35,0	32,0	58,7	79	30,2	68	41	21	11,5	M10x40	7/16 x 1 1/2	0,62		
210	1 1/2"	AFS-106ST40	48,3x3,7	48,6	40,9	38,0	69,9	93	35,7	78	44	25	13,5	M12x45	1/2 x 1 3/4	0,97		
210	2"	AFS-108ST40	60,3x3,9	61,0	52,5	51,0	77,8	102	42,9	90	45	25	13,5	M12x45	1/2 x 1 3/4	1,13		
175	2 1/2"	AFS-110ST40	73x5,1	73,0	62,8	–	88,9	114	50,8	105	50	25	13,5	M12x45	1/2 x 1 3/4	1,54		
160	3"	AFS-112ST40	88,9x5,5	92,0	77,9	73,0	106,4	134	61,9	124	50	27	17,5	M16x50	5/8 x 2	2,25		
35	3 1/2"	AFS-114ST40	101,6x5,7	103,0	90,1	89	120,7	152	69,9	136	48	27	17,5	M16x50	5/8 x 2	2,57		
35	4"	AFS-116ST40	114,3x6	115,5	102,3	99,0	130,2	162	77,8	146	48	27	17,5	M16x50	5/8 x 2	2,87		
35	5"	AFS-118ST40	141,3x6,6	142,0	128,1	120,0	152,4	184	92,1	180	50	28	17,5	M16x55	5/8 x 2	4,03		

*1 oder vergleichbare Güte / or comparable material

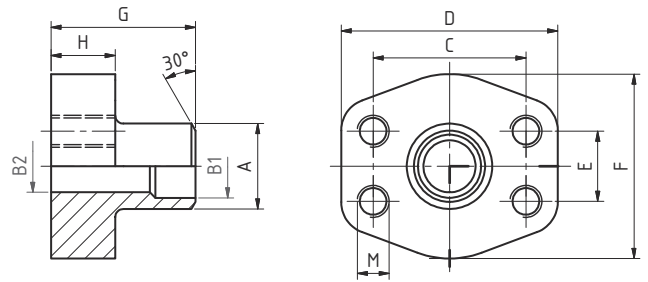

Bestellbezeichnung: ordering code:	S355J2^{*1}	1.4404^{*1} 316L
• Flansch mit metrischen Gewinden flange with metric threads	GFS-...ST40	GFX-...ST40
• Flansch mit UNC-Gewinden flange with unc threads	GFS-...ST40U	GFX-...ST40U

* Der angeführte maximale Betriebsdruck ist bezogen auf den Flansch! Der tatsächliche Betriebsdruck wird bestimmt durch das Rohr (Wandstärke) sowie die Güte des Rohres!
 The maximum recommended working pressure is based on the flange. The working pressure of the system is determined by the tube (thickness) and by the steel quality of the tube!

maximaler Betriebsdruck * maximum recommended working pressure	S.A.E. Baugröße nominal flange size	Typ type	Abmessungen dimensions											Gewinde thread		Gewicht weight	
			Rohr/tube	A	B1	B2	C	D	E	F	G	H	M	kg			
kg/cm ²	inch																
Schraube Festigkeitskl.													metr.	unc.			
10.9	Standarddruckreihe / Standard pressure																
350	1/2"	GFS-080ST40	21,3x2,8	21,5	15,7	13,0	38,1	54	17,5	46	36	16	M8	5/16-18	–		
350	3/4"	GFS-100ST40	26,7x2,9	28,0	20,9	19,0	47,6	65	22,3	50	36	18	M10	3/8-16	–		
320	1"	GFS-102ST40	33,4x3,4	34,0	26,6	25,0	52,4	70	26,2	55	38	18	M10	3/8-16	–		
280	1 1/4"	GFS-104ST40	42,4x3,6	42,8	35,0	32,0	58,7	79	30,2	68	41	21	M10	7/16-14	–		
210	1 1/2"	GFS-106ST40	48,3x3,7	48,6	40,9	38,0	69,9	93	35,7	78	44	25	M12	1/2-13	–		
210	2"	GFS-108ST40	60,3x3,9	61,0	52,5	51,0	77,8	102	42,9	90	45	25	M12	1/2-13	–		
175	2 1/2"	GFS-110ST40	73x5,1	73,0	62,8	–	88,9	114	50,8	105	50	25	M12	1/2-13	–		
160	3"	GFS-112ST40	88,9x5,5	92,0	77,9	73,0	106,4	134	61,9	124	50	27	M16	5/8-11	–		
35	3 1/2"	GFS-114ST40	101,6x5,7	103,0	90,1	89	120,7	152	69,9	136	48	27	M16	5/8-11	–		
35	4"	GFS-116ST40	114,3x6	115,5	102,3	99,0	130,2	162	77,8	146	48	27	M16	5/8-11	–		
35	5"	GFS-118ST40	141,3x6,6	142,0	128,1	120,0	152,4	184	92,1	180	50	28	M16	5/8-11	–		

*1 oder vergleichbare Güte / or comparable material

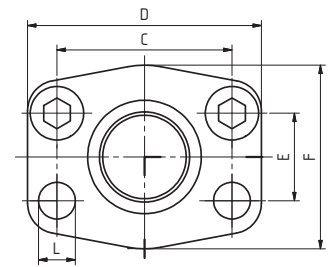
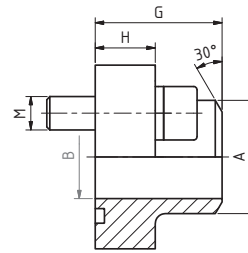

Bestellbezeichnung: ordering code:	S355J2^{*1}	1.4404^{*1} 316L
• nur Flansch flange only	AFS-...ST80	AFX-...ST80
• incl. metrischem Schraubensatz und O-Ring including metric bolts and o-ring	AFS-...ST80M	AFX-...ST80MX
• incl. UNC-Schraubensatz und O-Ring including unc bolts and o-ring	AFS-...ST80U	AFX-...ST80UX

* Der angeführte maximale Betriebsdruck ist bezogen auf den Flansch! Der tatsächliche Betriebsdruck wird bestimmt durch das Rohr (Wandstärke) sowie die Güte des Rohres!
The maximum recommended working pressure is based on the flange. The working pressure of the system is determined by the tube (thickness) and by the steel quality of the tube!

maximaler Betriebsdruck * maximum recommended working pressure	S.A.E. Baugröße nominal flange size	Typ type	Abmessungen dimensions											Schrauben bolts		Gewicht weight	
			Rohr/tube	A	B	C	D	E	F	G	H	L	M	kg			
kg/cm ²	inch																
Schraube Festigkeitskl. 10.9			Standarddruckreihe / Standard pressure											metr.	unc.		
350	1/2"	AFS-080ST80	21,3x3,8	21,5	13,8	38,1	54	17,5	46	36	16	9,0	M8x30	5/16 x 1 1/4	0,24		
350	3/4"	AFS-100ST80	26,7x3,9	28,0	19,0	47,6	65	22,3	50	36	18	11,0	M10x35	3/8 x 1 1/2	0,35		
320	1"	AFS-102ST80	33,4x4,6	34,0	25,0	52,4	70	26,2	55	38	18	11,0	M10x35	3/8 x 1 1/2	0,41		
280	1 1/4"	AFS-104ST80	42,2x4,9	42,8	32,0	58,7	79	30,2	68	41	21	11,5	M10x40	7/16 x 1 1/2	0,63		
210	1 1/2"	AFS-106ST80	48,3x5	48,6	38,0	69,9	93	35,7	78	44	25	13,5	M12x45	1/2 x 1 3/4	1,00		
210	2"	AFS-108ST80	60,3x5,6	61,0	49,1	77,8	102	42,9	90	45	25	13,5	M12x45	1/2 x 1 3/4	1,19		
175	2 1/2"	AFS-110ST80	73,0x7	73,2	59,0	88,9	114	50,8	105	50	25	13,5	M12x45	1/2 x 1 3/4	1,60		
160	3"	AFS-112ST80	88,9x7,6	92,0	73,0	106,4	134	61,9	124	50	27	17,5	M16x50	5/8 x 2	2,29		
35	3 1/2"	AFS-114ST80	101,6x8	103,0	85,6	120,7	152	69,9	136	48	27	17,5	M16x50	5/8 x 2	2,74		
35	4"	AFS-116ST80	114,3x8,56	115,5	97,2	130,2	162	77,8	146	48	27	17,5	M16x50	5/8 x 2	2,99		
35	5"	AFS-118ST80	141,3x9,52	142,0	122,3	152,4	184	92,1	180	50	28	17,5	M16x55	5/8 x 2	3,98		
Schraube Festigkeitskl. 10.9			Hochdruckreihe / High pressure											metr.	unc.		
420	1/2"	AFS-401ST80	21,3x3,7	21,5	13,9	40,5	54	18,2	46	36	16	9,0	M8x30	5/16 x 1 1/4	0,24		
420	3/4"	AFS-402ST80	26,7x3,9	28,0	19,0	50,8	71	23,8	55	35	21	11,0	M10x35	3/8 x 1 1/2	0,47		
420	1"	AFS-403ST80	33,4x4,5	34,0	25,0	57,2	79	27,8	68	41	21	13,0	M12x45	7/16 x 1 3/4	0,63		
420	1 1/4"	AFS-404ST80	42,2x4,8	42,8	32,0	66,6	93	31,8	78	44	25	15,0	M14x50	-	1,01		
420	1 1/4"	AFS-404ST80L=13,5	42,2x4,8	42,8	32,0	66,6	93	31,8	78	44	25	13,5	M12x45	1/2 x 1 3/4	1,00		
420	1 1/2"	AFS-405ST80	48,3x5	48,6	38,0	79,3	112	36,5	94	55	30	17,0	M16x50	5/8 x 2	1,74		
420	2"	AFS-406ST80	60,3x5,5	61,0	49,0	96,8	134	44,5	114	65	37	21,0	M20x70	3/4 x 2 1/2	2,87		
420	2 1/2"	AFS-407ST80	73x7,01	74,0	58,8	123,8	180	58,8	152	80	45	26,0	M24x80	-	6,73		

*1 oder vergleichbare Güte / or comparable material

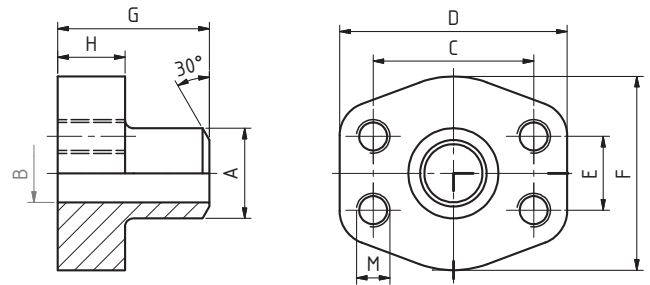

Bestellbezeichnung: ordering code:	S355J2^{*1}	1.4404^{*1} 316L
• Flansch mit metrischen Gewinden flange with metric threads	GFS-...ST80	GFX-...ST80
• Flansch mit UNC Gewinden flange with unc threads	GFS-...ST80U	GFX-...ST80U

* Der angeführte maximale Betriebsdruck ist bezogen auf den Flansch! Der tatsächliche Betriebsdruck wird bestimmt durch das Rohr (Wandstärke) sowie die Güte des Rohres!
 The maximum recommended working pressure is based on the flange. The working pressure of the system is determined by the tube (thickness) and by the steel quality of the tube!

maximaler Betriebsdruck * maximum recommended working pressure	S.A.E. Baugröße nominal flange size	Typ type	Abmessungen dimensions										Gewinde thread		Gewicht weight	
			Rohr/tube	A	B	C	D	E	F	G	H	M	kg			
kg/cm ²	inch															
Schraube Festigkeitskl. 10.9	Standarddruckreihe / Standard pressure												metr.	unc.		
350	1/2"	GFS-080ST80	21,3x3,8	21,5	13,8	38,1	54	17,5	46	36	16	M8	5/16-18	-		
350	3/4"	GFS-100ST80	26,7x3,9	28,0	19,0	47,6	65	22,3	50	36	18	M10	3/8-16	-		
320	1"	GFS-102ST80	33,4x4,6	34,0	25,0	52,4	70	26,2	55	38	18	M10	3/8-16	-		
280	1 1/4"	GFS-104ST80	42,2x4,9	42,8	32,0	58,7	79	30,2	68	41	21	M10	7/16-14	-		
210	1 1/2"	GFS-106ST80	48,3x5	48,6	38,0	69,9	93	35,7	78	44	25	M12	1/2-13	-		
210	2"	GFS-108ST80	60,3x5,6	61,0	49,1	77,8	102	42,9	90	45	25	M12	1/2-13	-		
175	2 1/2"	GFS-110ST80	73,0x7	73,2	59,0	88,9	114	50,8	105	50	25	M12	1/2-13	-		
160	3"	GFS-112ST80	88,9x7,6	92,0	73,0	106,4	134	61,9	124	50	27	M16	5/8-11	-		
35	3 1/2"	GFS-114ST80	101,6x8	103,0	85,6	120,7	152	69,9	136	48	27	M16	5/8-11	-		
35	4"	GFS-116ST80	114,3x8,56	115,5	97,2	130,2	162	77,8	146	48	27	M16	5/8-11	-		
35	5"	GFS-118ST80	141,3x9,52	142,0	122,3	152,4	184	92,1	180	50	28	M16	5/8-11	-		
Schraube Festigkeitskl. 10.9	Hochdruckreihe / High pressure												metr.	unc.		
420	1/2"	GFS-401ST80	21,3x3,7	21,5	13,9	40,5	54	18,2	46	36	16	M8	5/16-18	-		
420	3/4"	GFS-402ST80	26,7x3,9	28,0	19,0	50,8	71	23,8	55	35	21	M10	3/8-16	-		
420	1"	GFS-403ST80	33,4x4,5	34,0	25,0	57,2	79	27,8	68	41	21	M12	7/16-14	-		
420	1 1/4"	GFS-404ST80	42,2x4,8	42,8	32,0	66,6	93	31,8	78	44	25	M14	-	-		
420	1 1/4"	GFS-404ST80-M12	42,2x4,8	42,8	32,0	66,6	93	31,8	78	44	25	M12	1/2-13	1,05		
420	1 1/2"	GFS-405ST80	48,3x5	48,6	38,0	79,3	112	36,5	94	55	30	M16	5/8-11	-		
420	2"	GFS-406ST80	60,3x5,5	61,0	49,2	96,8	134	44,5	114	65	37	M20	3/4-10	-		
420	2 1/2"	GFS-407ST80	73x7,01	74,0	58,8	123,8	180	58,8	152	80	45	M24	-	-		

*1 oder vergleichbare Güte / or comparable material

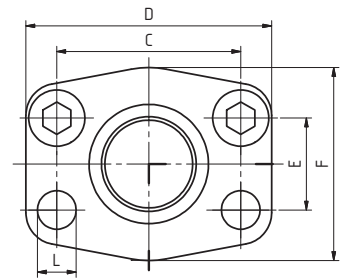
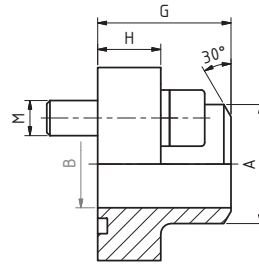

Bestellbezeichnung: ordering code:	S355J2^{*1}	1.4404^{*1} 316L
• nur Flansch flange only	AFS-...ST160	AFX-...ST160
• incl. metrischem Schraubensatz und O-Ring including metric bolts and o-ring	AFS-...ST160M	AFX-...ST160MX
• incl. UNC-Schraubensatz und O-Ring including unc bolts and o-ring	AFS-...ST160U	AFX-...ST160UX

* Der angeführte maximale Betriebsdruck ist bezogen auf den Flansch! Der tatsächliche Betriebsdruck wird bestimmt durch das Rohr (Wandstärke) sowie die Güte des Rohres!
The maximum recommended working pressure is based on the flange. The working pressure of the system is determined by the tube (thickness) and by the steel quality of the tube!

maximaler Betriebsdruck * maximum recommended working pressure	S.A.E. Baugröße nominal flange size	Typ type	Abmessungen dimensions											Schrauben bolts		Gewicht weight	
			Rohr/tube	A	B	C	D	E	F	G	H	L	M		kg		
kg/cm ²	inch																
Schraube Festigkeitskl. 10.9	Hochdruckreihe / High pressure													metr.	unc.		
420	1/2"	AFS-401ST160	21,3x4,8	21,5	11,7	40,5	54	18,2	46	36	16	9,0	M8x30	5/16 x 1 1/4	0,25		
420	3/4"	AFS-402ST160	26,7x5,6	26,9	15,7	50,8	71	23,8	55	35	21	11,0	M10x35	3/8 x 1 1/2	0,48		
420	1"	AFS-403ST160	33,4x6,35	34,0	20,7	57,2	79	27,8	68	41	21	13,0	M12x45	7/16 x 1 3/4	0,67		
420	1 1/4"	AFS-404ST160	42,2x6,35	42,8	29,5	66,6	93	31,8	78	44	25	15,0	M14x50	–	1,05		
420	1 1/4"	AFS-404ST160L13,5	42,2x6,35	42,8	29,5	66,6	93	31,8	78	44	25	13,5	M12x45	1/2 x 1 3/4	1,07		
420	1 1/2"	AFS-405ST160	48,3x7,14	48,6	34,0	79,3	112	36,5	94	55	30	17,0	M16x50	5/8 x 2	1,83		
420	2"	AFS-406ST160	60,3x8,7	61,0	43,0	96,8	134	44,5	114	65	37	21,0	M20x70	3/4 x 2 1/2	3,15		
420	2 1/2"	AFS-407ST160	73x9,5	74,0	54,0	123,8	180	58,8	152	80	45	26,0	M24x80	–	6,97		
420	3"	AFS-408ST160	88,9x11,13	90,0	66,6	152,4	208	71,6	178	90	55	33,0	M30x90	–	11,05		

*1 oder vergleichbare Güte / or comparable material

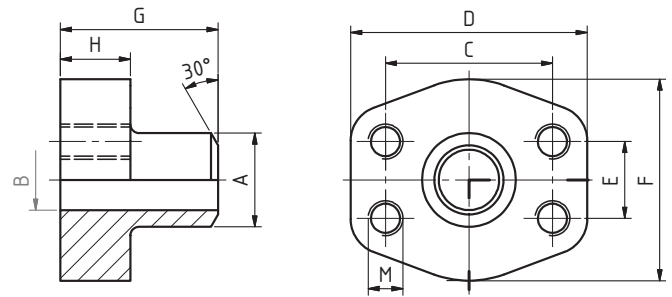

Bestellbezeichnung: ordering code:	S355J2^{*1}	1.4404^{*1} 316L
• Flansch mit metrischen Gewinden flange with metric threads	GFS-...ST160	GFX-...ST160
• Flansch mit UNC Gewinden flange with unc threads	GFS-...ST160U	GFX-...ST160U

* Der angeführte maximale Betriebsdruck ist bezogen auf den Flansch! Der tatsächliche Betriebsdruck wird bestimmt durch das Rohr (Wandstärke) sowie die Güte des Rohres!
 The maximum recommended working pressure is based on the flange. The working pressure of the system is determined by the tube (thickness) and by the steel quality of the tube!

maximaler Betriebsdruck * maximum recommended working pressure	S.A.E. Baugröße nominal flange size	Typ type	Abmessungen dimensions										Schrauben bolts		Gewicht weight	
			Rohr/tube	A	B	C	D	E	F	G	H	M	kg			
kg/cm ²	inch															
Schraube Festigkeitskl. 10.9	Hochdruckreihe / High pressure											metr.	unc.			
420	1/2"	GFS-401ST160	21,3x4,8	21,5	11,7	40,5	54	18,2	46	36	16	M8	5/16-18	–		
420	3/4"	GFS-402ST160	26,7x5,6	26,9	15,7	50,8	71	23,8	55	35	21	M10	3/8-16	–		
420	1"	GFS-403ST160	33,4x6,35	34,0	20,7	57,2	79	27,8	68	41	21	M12	7/16-14	–		
420	1 1/4"	GFS-404ST160	42,2x6,35	42,8	29,5	66,6	93	31,8	78	44	25	M14	–	–		
420	1 1/4"	GFS-404ST160-M12	42,2x6,35	42,8	29,5	66,6	93	31,8	78	44	25	M12	1/2-13	1,12		
420	1 1/2"	GFS-405ST160	48,3x7,14	48,6	34,0	79,3	112	36,5	94	55	30	M16	5/8-11	–		
420	2"	GFS-406ST160	60,3x8,7	61,0	43,0	96,8	134	44,5	114	65	37	M20	3/4-10	–		
420	2 1/2"	GFS-407ST160	73x9,5	74,0	54,0	123,8	180	58,8	152	80	45	M24	–	–		
420	3"	GFS-408ST160	88,9x11,13	90,0	66,6	152,4	208	71,6	178	90	55	M30	–	–		

*1 oder vergleichbare Güte / or comparable material

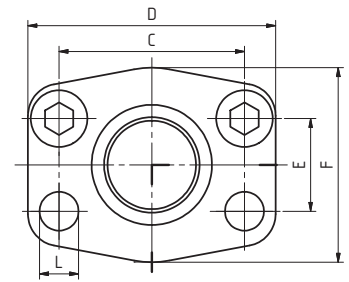
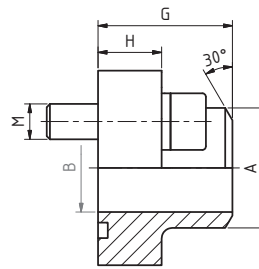

Bestellbezeichnung: ordering code:	S355J2^{*1}	1.4404^{*1} 316L
• nur Flansch flange only	AFS-...ST-XX	AFX-...ST-XX
• incl. metrischem Schraubensatz und O-Ring including metric bolts and o-ring	AFS-...ST-XXM	AFX-...ST-XXMX
• incl. UNC-Schraubensatz und O-Ring including unc bolts and o-ring	AFS-...ST-XXU	AFX-...ST-XXUX

* Der angeführte maximale Betriebsdruck ist bezogen auf den Flansch! Der tatsächliche Betriebsdruck wird bestimmt durch das Rohr (Wandstärke) sowie die Güte des Rohres!
The maximum recommended working pressure is based on the flange. The working pressure of the system is determined by the tube (thickness) and by the steel quality of the tube!

maximaler Betriebsdruck * maximum recommended working pressure	S.A.E. Baugröße nominal flange size	Typ type	Abmessungen dimensions											Schrauben bolts		Gewicht weight	
			Rohr/tube	A	B	C	D	E	F	G	H	L	M		kg		
kg/cm ²	inch																
Schraube Festigkeitskl. 10.9	Hochdruckreihe / High pressure														metr.	unc.	
420	1/2"	AFS-401ST-XX	21,3x7,47	21,5	6,4	40,5	54	18,2	46	36	16	9,0	M8x30	5/16 x 1 1/4	0,26		
420	3/4"	AFS-402ST-XX	26,7x7,82	26,9	11,0	50,8	71	23,8	55	35	21	11,0	M10x35	3/8 x 1 1/2	0,51		
420	1"	AFS-403ST-XX	33,4x9,09	34,0	15,2	57,2	79	27,8	68	41	21	13,0	M12x45	7/16 x 1 3/4	0,72		
420	1 1/4"	AFS-404ST-XX	42,2x9,7	42,8	22,8	66,6	93	31,8	78	44	25	13,5	M14x50	–	1,16		
420	1 1/4"	AFS-404ST-XXL=13,5	42,2x9,7	42,8	22,8	66,6	93	31,8	78	44	25	13,5	M12x45	1/2 x 1 3/4	1,16		
420	1 1/2"	AFS-405ST-XX	48,3x10,16	48,6	28,0	79,3	112	36,5	94	55	30	17,0	M16x50	5/8 x 2	1,95		
420	2"	AFS-406ST-XX	60,3x11,07	61,0	38,2	96,8	134	44,5	114	65	37	21,0	M20x70	3/4 x 2 1/2	3,29		
420	2 1/2"	AFS-407ST-XX	73x14,02	74,0	44,9	123,8	180	58,8	152	80	45	26,0	M24x80	–	7,37		
420	3"	AFS-408ST-XX	88,9x15,24	90,0	58,4	152,4	208	71,6	178	90	55	33,0	M30x90	–	11,56		

*1 oder vergleichbare Güte / or comparable material

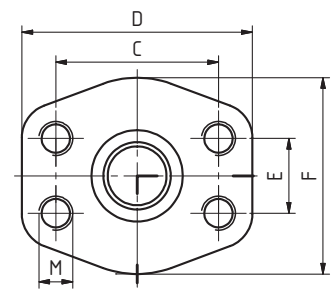
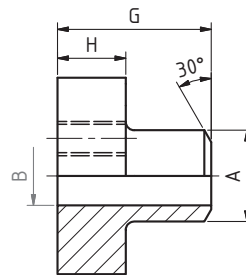

Bestellbezeichnung: ordering code:	S355J2^{*1}	1.4404^{*1} 316L
• Flansch mit metrischen Gewinden flange with metric threads	GFS-...ST-XX	GFX-...ST-XX
• Flansch mit UNC Gewinden flange with unc threads	GFS-...ST-XXU	GFX-...ST-XXU

* Der angeführte maximale Betriebsdruck ist bezogen auf den Flansch! Der tatsächliche Betriebsdruck wird bestimmt durch das Rohr (Wandstärke) sowie die Güte des Rohres!
The maximum recommended working pressure is based on the flange. The working pressure of the system is determined by the tube (thickness) and by the steel quality of the tube!

maximaler Betriebsdruck * maximum recommended working pressure	S.A.E. Baugröße nominal flange size	Typ type	Abmessungen dimensions									Schrauben bolts		Gewicht weight	
			Rohr/tube	A	B	C	D	E	F	G	H	M	kg		
kg/cm ²	inch														
Schraube Festigkeitskl. 10.9	Hochdruckreihe / High pressure											metr.	unc.		
420	1/2"	GFS-401ST-XX	21,3x7,47	21,5	6,4	40,5	54	18,2	46	36	16	M8	5/16-18	-	
420	3/4"	GFS-402ST-XX	26,7x7,82	26,9	11,0	50,8	71	23,8	55	35	21	M10	3/8-16	-	
420	1"	GFS-403ST-XX	33,4x9,09	34,0	15,2	57,2	79	27,8	68	41	21	M12	7/16-14	-	
420	1 1/4"	GFS-404ST-XX	42,2x9,7	42,8	22,8	66,6	93	31,8	78	44	25	M14	-	-	
420	1 1/4"	GFS-404ST-XX-M12	42,2x9,7	42,8	22,8	66,6	93	31,8	78	44	25	M12	1/2-13	1,25	
420	1 1/2"	GFS-405ST-XX	48,3x10,16	48,6	28,0	79,3	112	36,5	94	55	30	M16	5/8-11	-	
420	2"	GFS-406ST-XX	60,3x11,07	61,0	38,2	96,8	134	44,5	114	65	37	M20	3/4-10	-	
420	2 1/2"	GFS-407ST-XX	73x14,02	74,0	44,9	123,8	180	58,8	152	80	45	M24	-	-	
420	3"	GFS-408ST-XX	88,9x15,24	90,0	58,4	152,4	208	71,6	178	90	55	M30	-	-	

*1 oder vergleichbare Güte / or comparable material

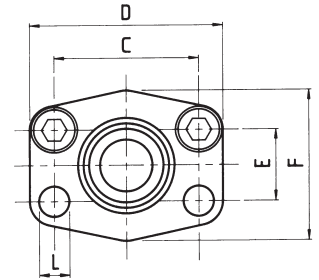
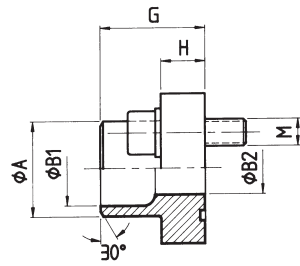

Bestellbezeichnung: <i>ordering code:</i>	S355J2^{*1}	1.4404^{*1} 316L
• nur Flansch <i>flange only</i>	AFS-...STRE	AFX-... STRE
• incl. metrischem Schraubensatz und O-Ring <i>including metric bolts and o-ring</i>	AFS-...STREM	AFX-...STREMX
• incl. UNC-Schraubensatz und O-Ring <i>including UNC bolts and o-ring</i>	AFS-...STREU	AFX-...STREUX

* Der angeführte maximale Betriebsdruck ist bezogen auf den Flansch! Der tatsächliche Betriebsdruck wird bestimmt durch das Rohr (Wandstärke) sowie die Güte des Rohres!
The maximum recommended working pressure is based on the flange. The working pressure of the system is determined by the tube (thickness) and by the steel quality of the tube!

maximaler Betriebsdruck * <i>maximum recommended working pressure</i>	S.A.E. Baugröße <i>nominal flange size</i>	Typ <i>type</i>	Rohr/tube	Abmessungen <i>dimensions</i>											Schrauben <i>bolts</i>		Gewicht <i>weight</i>	
				A	B1	B2	C	D	E	F	G	H	L	M	kg			
kg/cm ²	inch																	
Schraube Festigkeitskl.																<i>metr.</i>	<i>unc.</i>	
10.9	Standarddruckreihe / Standard pressure																	
350	1/2"	AFS 080 STRE 21,3	21,3x2,6	22,0	16,0	13	38,1	54	17,5	46	35,0	16,0	9,0	M 8x30	5/16 x 1 1/4	0,28		
350	3/4"	AFS 100 STRE 26,9	26,9x2,6	28,0	21,5	19	47,6	65	22,3	50	36,0	18,0	11,0	M 10x35	3/8 x 1 1/2	0,39		
320	1"	AFS 102 STRE 33,7	33,7x3,2	35,0	27,0	25	52,4	70	26,2	55	38,0	18,0	11,0	M 10x35	3/8 x 1 1/2	0,46		
280	1 1/4"	AFS 104 STRE 42,4	42,4x3,2	43,0	36,0	31	58,7	79	30,2	68	41,0	21,0	11,5	M 10x40	7/16 x 1 1/2	0,66		
210	1 1/2"	AFS 106 STRE 48,3	48,3x3,2	49,0	42,0	38	69,9	93	35,7	78	44,0	25,0	13,5	M 12x45	1/2 x 1 3/4	1,05		
210	2"	AFS 108 STRE 48,3	48,3x3,2	49,0	42,0	42	77,8	102	42,9	90	45,0	25,0	13,5	M 12x45	1/2 x 1 3/4	1,12		
210	2"	AFS 108 STRE 60,3	60,3x3,6	61,0	53,0	49	77,8	102	42,9	90	45,0	25,0	13,5	M 12x45	1/2 x 1 3/4	1,19		
175	2 1/2"	AFS 110 STRE 60,3	60,3x3,6	61,0	53,0	53	88,9	114	50,8	105	50,0	25,0	13,5	M 12x45	1/2 x 1 3/4	1,31		
175	2 1/2"	AFS 110 STRE 76,1	76,1x3,6	77,0	70,0	62	88,9	114	50,8	105	50,0	25,0	13,5	M 12x45	1/2 x 1 3/4	1,40		
160	3"	AFS 112 STRE 76,1	76,1x3,6	77,0	69,0	–	106,4	134	61,9	124	51,0	26,0	17,5	M 16x50	5/8 x 2	2,05		
160	3"	AFS 112 STRE 88,9	88,9x3,6	90,0	82,0	74	106,4	134	61,9	124	51,0	26,0	17,5	M 16x50	5/8 x 2	2,15		
35	3 1/2"	AFS 114 STRE 88,9	88,9x3,6	90,0	82,0	82	120,7	152	69,9	136	48,0	26,0	17,5	M 16x50	5/8 x 2	2,40		
35	3 1/2"	AFS 114 STRE 76,1	76,1x3,6	77,0	70,0	70	120,7	152	69,9	136	48,0	26,0	17,5	M 16x50	5/8 x 2	2,38		
35	4"	AFS 116 STRE 88,9	88,9x3,6	90,0	82,0	82	130,2	162	77,8	146	48,0	26,0	17,5	M 16x50	5/8 x 2	2,75		
35	4"	AFS 116 STRE 114	114x3,6	115,0	107,0	102	130,2	162	77,8	146	48,0	26,0	17,5	M 16x50	5/8 x 2	2,85		
35	5"	AFS 118 STRE 139FL	139,7x4	141,0	–	131	152,4	190	92,1	170	28,0	28,0	17,5	M 16x55	5/8 x 2	2,80		
35	5"	AFS 118 STRE 139	139,7x4	140,2	131,0	120	152,4	184	92,1	180	50,0	28,0	17,5	M 16x55	5/8 x 2	5,00		

Ausführung AFS-118 STRE 139-FL als Flachflansch zum Einschweißen / *type AFS-118 STRE 139-FL as flat flange for welding*

*1 oder vergleichbare Güte / *or comparable material*

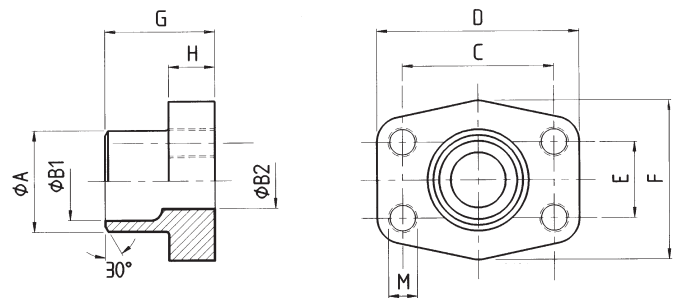

Bestellbezeichnung: ordering code:	S355J2^{*1}	1.4404^{*1} 316L
• nur Flansch flange only	GFS-...STRE	GFX-...STRE

* Der angeführte maximale Betriebsdruck ist bezogen auf den Flansch! Der tatsächliche Betriebsdruck wird bestimmt durch das Rohr (Wandstärke) sowie die Güte des Rohres!
 The maximum recommended working pressure is based on the flange. The working pressure of the system is determined by the tube (thickness) and by the steel quality of the tube!

maximaler Betriebsdruck * maximum recommended working pressure	S.A.E. Baugröße nominal flange size	Typ type	Rohr/tube	Abmessungen dimensions										Gewinde thread	Gewicht weight	
				A	B1	B2	C	D	E	F	G	H	M			kg
kg/cm ²	inch															
Schraube Festigkeitskl. 10.9	Standarddruckreihe / Standard pressure															
350	1/2"	GFS 080 STRE 21,3	21,3x2,6	22,0	16,0	13	38,1	54	17,5	46	35,0	16,0	M 8	0,28		
350	3/4"	GFS 100 STRE 26,9	26,9x2,6	28,0	21,5	19	47,6	65	22,3	50	36,0	18,0	M 10	0,39		
320	1"	GFS 102 STRE 33,7	33,7x3,2	35,0	27,0	25	52,4	70	26,2	55	38,0	18,0	M 10	0,46		
280	1 1/4"	GFS 104 STRE 42,4	42,4x3,2	43,0	36,0	31	58,7	79	30,2	68	41,0	21,0	M 10	0,66		
210	1 1/2"	GFS 106 STRE 48,3	48,3x3,2	49,0	42,0	38	69,9	93	35,7	78	44,0	25,0	M 12	1,05		
210	2"	GFS 108 STRE 48,3	48,3x3,2	49,0	42,0	42	77,8	102	42,9	90	45,0	25,0	M 12	1,20		
210	2"	GFS 108 STRE 60,3	60,3x3,6	61,0	53,0	49	77,8	102	42,9	90	45,0	25,0	M 12	1,25		
175	2 1/2"	GFS 110 STRE 60,3	60,3x3,6	61,0	53,0	53	88,9	114	50,8	105	50,0	25,0	M 12	1,29		

Ausführung AFS-118 STRE 139-FL als Flachflansch zum Einschweißen / type AFS-118 STRE 193-FL as flat flange for welding

*1 oder vergleichbare Güte / or comparable material

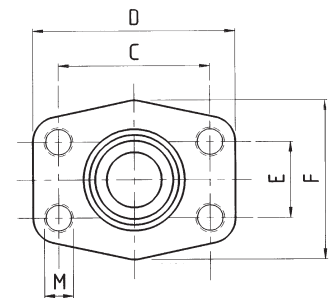
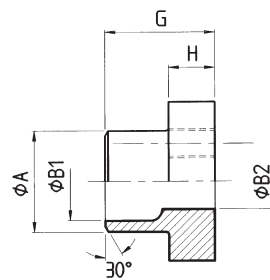

Bestellbezeichnung: ordering code:	S355J2^{*1}	1.4404^{*1} 316L
• nur Flansch flange only	GFS-...STRE	GFX-...STRE

* Der angeführte maximale Betriebsdruck ist bezogen auf den Flansch! Der tatsächliche Betriebsdruck wird bestimmt durch das Rohr (Wandstärke) sowie die Güte des Rohres!
 The maximum recommended working pressure is based on the flange. The working pressure of the system is determined by the tube (thickness) and by the steel quality of the tube!

maximaler Betriebsdruck * maximum recommended working pressure	S.A.E. Baugröße nominal flange size	Typ type	Rohr/tube	Abmessungen dimensions									Gewinde thread	Gewicht weight		
				A	B1	B2	C	D	E	F	G	H			M	kg
kg/cm ²	inch															
Schraube Festigkeitskl. 10.9	Standarddruckreihe / Standard pressure															
175	2½"	GFS 110 STRE 76,1	76,1x3,6	77,0	70,0	62	88,9	114	50,8	105	50,0	25,0	M 12	1,40		
160	3"	GFS 112 STRE 88,9	88,9x3,6	90,0	82,0	74	106,4	134	61,9	124	51,0	26,0	M 16	2,15		
35	3½"	GFS 114 STRE 88,9	88,9x3,6	90,0	82,0	82	120,7	152	69,9	136	48,0	26,0	M 16	2,40		
35	3½"	GFS 114 STRE 76,1	76,1x3,6	77,0	70,0	70	120,7	152	69,9	136	48,0	26,0	M 16	2,40		
35	4"	GFS 116 STRE 88,9	88,9x3,6	90,0	82,0	82	130,2	162	77,8	146	48,0	26,0	M 16	2,69		
35	4"	GFS 116 STRE 114	114,3x3,6	115,0	107,0	102	130,2	162	77,8	146	48,0	26,0	M 16	2,85		
35	5"	GFS 118 STRE 139FL	139,7x4	141,0	–	131	152,4	190	92,1	170	28,0	28,0	M 16	2,80		
35	5"	GFS 118 STRE 139	139,7x4	140,2	131,0	120	152,4	184	92,1	180	50,0	28,0	M 16	5,00		

Ausführung AFS-118 STRE 139-FL als Flachflansch zum Einschweißen / type AFS-118 STRE 139-FL as flat flange for welding

*1 oder vergleichbare Güte / or comparable material

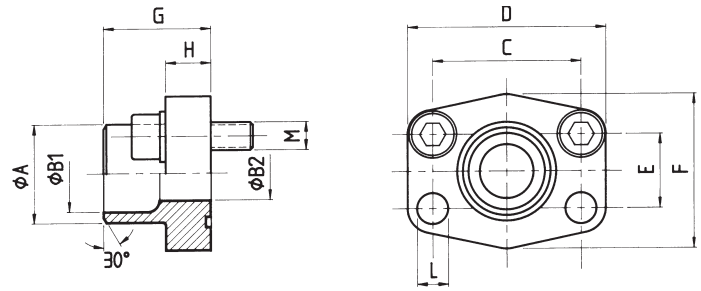

Bestellbezeichnung: ordering code:	S355J2^{*1}	1.4404^{*1} 316L
• nur Flansch flange only	AFS-...SRE	AFX-...SRE
• incl. metrischem Schraubensatz und O-Ring including metric bolts and o-ring	AFS-...SREM	AFX-...SREMX
• incl. UNC-Schraubensatz und O-Ring including UNC bolts and o-ring	AFS-...SREU	AFX-...SREUX

* Der angeführte maximale Betriebsdruck ist bezogen auf den Flansch! Der tatsächliche Betriebsdruck wird bestimmt durch das Rohr (Wandstärke) sowie die Güte des Rohres!
The maximum recommended working pressure is based on the flange. The working pressure of the system is determined by the tube (thickness) and by the steel quality of the tube!

maximaler Betriebsdruck* maximum recommended working pressure	S.A.E. Baugröße nominal flange size	Typ type	Abmessungen dimensions											Schrauben bolts		Gewicht weight			
			Rohr/tube	A	B1	B2	C	D	E	F	G	H	L	M	unc.		kg		
kg/cm ²	inch																metr.	unc.	
Schraube Festigkeitskl. 10.9	Standarddruckreihe / Standard pressure																		
350	1/2"	AFS 080 SRE 20	20x3	20	14,0	14	38,1	54	17,5	46	35,0	16,0	9,0	M 8x30	5/16 x 1 1/4	0,28			
350	1/2"	AFS 080 SRE 22	22x3	22	16,0	13	38,1	54	17,5	46	35,0	16,0	9,0	M 8x30	5/16 x 1 1/4	0,28			
350	3/4"	AFS 100 SRE 25	25x3	25	19,0	19	47,6	65	22,3	50	36,0	18,0	11,0	M 10x35	3/8 x 1 1/2	0,39			
350	3/4"	AFS 100 SRE 28	28x3	28	21,5	19	47,6	65	22,3	50	36,0	18,0	11,0	M 10x35	3/8 x 1 1/2	0,39			
320	1"	AFS 102 SRE 30	30x4	30	22,0	22	52,4	70	26,2	55	38,0	18,0	11,0	M 10x35	3/8 x 1 1/2	0,46			
320	1"	AFS 102 SRE 35	35x4	35	27,0	25	52,4	70	26,2	55	38,0	18,0	11,0	M 10x35	3/8 x 1 1/2	0,47			
280	1 1/4"	AFS 104 SRE 38	38x4	38	30,0	30	58,7	79	30,2	68	41,0	21,0	11,5	M 10x40	7/16 x 1 1/2	0,66			
280	1 1/4"	AFS 104 SRE 42	42x3	43	36,0	31	58,7	79	30,2	68	41,0	21,0	11,5	M 10x40	7/16 x 1 1/2	0,66			
210	1 1/2"	AFS 106 SRE 38	38x4	38	30,0	30	69,9	93	35,7	78	44,0	25,0	13,5	M 12x45	1/2 x 1 3/4	1,05			
210	1 1/2"	AFS 106 SRE 42	42x3	42	36,0	36	69,9	93	35,7	78	44,0	25,0	13,5	M 12x45	1/2 x 1 3/4	1,05			
210	1 1/2"	AFS 106 SRE 48	48,3x5,0	49	38,0	38	69,9	93	35,7	78	44,0	25,0	13,5	M 12x45	1/2 x 1 3/4	1,05			
210	2"	AFS 108 SRE 60	60,3x5,6	61	49,0	49	77,8	102	42,9	90	45,0	25,0	13,5	M 12x45	1/2 x 1 3/4	1,20			
175	2 1/2"	AFS 110 SRE 76	76,1x7,1	77	62,0	62	88,9	114	50,8	105	50,0	25,0	13,5	M 12x45	1/2 x 1 3/4	1,40			
160	3"	AFS 112 SRE 76	76,1x7,1	77	62,0	62	106,4	134	61,9	124	51,0	26,0	17,5	M 16x50	5/8 x 2	2,15			

*1 oder vergleichbare Güte / or comparable material

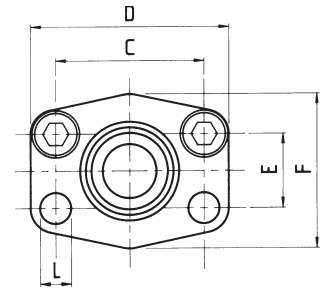
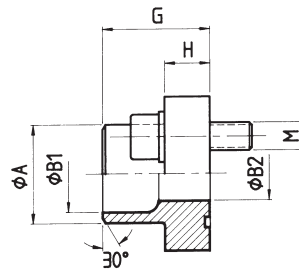

Bestellbezeichnung: ordering code:	S355J2^{*1}	1.4404^{*1} 316L
• nur Flansch flange only	AFS-...SRE	AFX-...SRE
• incl. metrischem Schraubensatz und O-Ring including metric bolts and o-ring	AFS-...SREM	AFX-...SREMX
• incl. UNC-Schraubensatz und O-Ring including UNC bolts and o-ring	AFS-...SREU	AFX-...SREUX

* Der angeführte maximale Betriebsdruck ist bezogen auf den Flansch! Der tatsächliche Betriebsdruck wird bestimmt durch das Rohr (Wandstärke) sowie die Güte des Rohres!
The maximum recommended working pressure is based on the flange. The working pressure of the system is determined by the tube (thickness) and by the steel quality of the tube!

maximaler Betriebsdruck* maximum recommended working pressure	S.A.E. Baugröße nominal flange size	Typ type	Abmessungen dimensions											Schrauben bolts		Gewicht weight		
			Rohr/tube	A	B1	B2	C	D	E	F	G	H	L	M	kg			
kg/cm ²	inch																	
Schraube Festigkeitskl.	Hochdruckreihe / High pressure														<i>metr.</i>	<i>unc.</i>		
10.9																		
420	1/2"	AFS 401 SRE 20	20x3	20	14	14	40,5	54	18,2	46	34	16	9,0	M 8x30	5/16 x 1 1/4	0,29		
420	3/4"	AFS 402 SRE 20	20x3	20	14	14	50,8	71	23,8	55	35	21	11,0	M 10x35	3/8 x 1 1/2	0,50		
420	3/4"	AFS 402 SRE 25	25x4	25	17	17	50,8	71	23,8	55	35	21	11,0	M 10x35	3/8 x 1 1/2	0,53		
420	1"	AFS 403 SRE 25	25x4	25	17	17	57,2	81	27,8	65	42	25	13,0	M 12x45	7/16 x 1 1/2	0,76		
420	1"	AFS 403 SRE 30	30x4	30	22	22	57,2	81	27,8	65	42	25	13,0	M 12x45	7/16 x 1 1/2	0,80		
420	1 1/4"	AFS 404 SRE 30	30x4	30	22	22	66,6	95	31,8	78	44	25	15,0	M 14x50	–	1,03		
420	1 1/4"	AFS 404 SRE 30L=13,5	30x4	30	22	22	66,6	95	31,8	78	44	25	13,5	M 12x45	1/2 x 1 3/4	1,04		
420	1 1/4"	AFS 404 SRE 38	38x6	38	26	26	66,6	95	31,8	78	44	25	15,0	M 14x50	–	1,04		
420	1 1/4"	AFS 404 SRE 38L=13,5	38x6	38	26	26	66,6	95	31,8	78	44	25	13,5	M 12x45	1/2 x 1 3/4	1,06		
420	1 1/2"	AFS 405 SRE 38	38x6	38	26	26	79,3	112	36,5	94	56	28	17,0	M 16x50	5/8 x 2	1,52		
420	1 1/2"	AFS 405 SRE 48	48,3x8	49	32	32	79,3	112	36,5	94	56	28	17,0	M 16x50	5/8 x 2	1,57		
420	1 1/2"	AFS 405 SRE 60	60,3x10	61	40	38	79,3	112	36,5	94	56	28	17,0	M 16x50	5/8 x 2	1,65		
420	2"	AFS 406 SRE 60	60,3x10	61	40	40	96,8	134	44,5	114	65	37	21,0	M 20x70	3/4 x 2 1/2	2,45		
420	2"	AFS 406 SRE 76	76,1x12,5	77	51	48	96,8	134	44,5	114	80	33	21,0	M 20x65	3/4 x 2 1/2	2,96		

*1 oder vergleichbare Güte / or comparable material

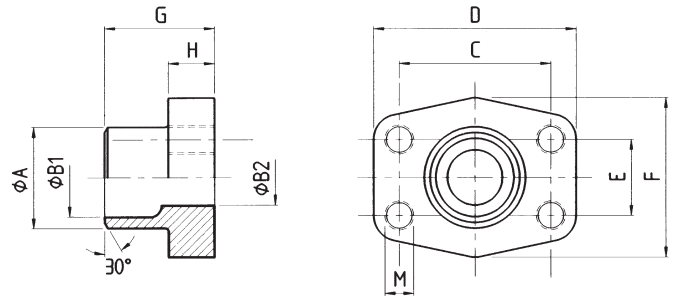

Bestellbezeichnung: ordering code:	S355J2^{*1}	1.4404^{*1} 316L
• nur Flansch flange only	GFS-...SRE	GFX-...SRE

* Der angeführte maximale Betriebsdruck ist bezogen auf den Flansch! Der tatsächliche Betriebsdruck wird bestimmt durch das Rohr (Wandstärke) sowie die Güte des Rohres!
The maximum recommended working pressure is based on the flange. The working pressure of the system is determined by the tube (thickness) and by the steel quality of the tube!

maximaler Betriebsdruck* maximum recommended working pressure	S.A.E. Baugröße nominal flange size	Typ type	Abmessungen dimensions										Gewinde thread	Gewicht weight			
			Rohr/tube	A	B1	B2	C	D	E	F	G	H			M	kg	
kg/cm ²	inch																
Schraube Festigkeitskl.																	
Standarddruckreihe / Standard pressure																	
10.9																	
350	1/2"	GFS 080 SRE 20	20x3	20	14,0	14	38,1	54	17,5	46	35,0	16,0	M 8	0,28			
350	1/2"	GFS 080 SRE 22	22x3	22	16,0	13	38,1	54	17,5	46	35,0	16,0	M 8	0,28			
350	3/4"	GFS 100 SRE 25	25x3	25	19,0	19	47,6	65	22,3	50	36,0	18,0	M 10	0,39			
350	3/4"	GFS 100 SRE 28	28x3	28	21,5	19	47,6	65	22,3	50	36,0	18,0	M 10	0,39			
320	1"	GFS 102 SRE 30	30x4	30	22,0	22	52,4	70	26,2	55	38,0	18,0	M 10	0,46			
320	1"	GFS 102 SRE 35	35x4	35	27,0	25	52,4	70	26,2	55	38,0	18,0	M 10	0,47			
280	1 1/4"	GFS 104 SRE 38	38x4	38	30,0	30	58,7	79	30,2	68	41,0	21,0	M 10	0,66			
280	1 1/4"	GFS 104 SRE 42	42x3	43	36,0	31	58,7	79	30,2	68	41,0	21,0	M 10	0,66			
210	1 1/2"	GFS 106 SRE 38	38x4	38	30,0	30	69,9	93	35,7	78	44,0	25,0	M 12	1,05			
210	1 1/2"	GFS 106 SRE 42	42x3	42	36,0	36	69,9	93	35,7	78	44,0	25,0	M 12	1,05			
210	1 1/2"	GFS 106 SRE 48	48,3x5,0	49	38,0	38	69,9	93	35,7	78	44,0	25,0	M 12	1,05			
210	2"	GFS 108 SRE 60	60,3x5,6	61	49,0	49	77,8	102	42,9	90	45,0	25,0	M 12	1,20			
175	2 1/2"	GFS 110 SRE 76	76,1x7,1	77	62,0	62	88,9	114	50,8	105	50,0	25,0	M 12	1,40			
160	3"	GFS 112 SRE 76	76,1x7,1	77	62,0	62	106,4	134	61,9	125	51,0	26,0	M 16	2,15			
Schraube Festigkeitskl.																	
10.9																	
Hochdruckreihe / High pressure																	
420	1/2"	GFS 401 SRE 20	20x3	20	14,0	14	40,5	54	18,2	46	34,0	16,0	M 8	0,29			
420	3/4"	GFS 402 SRE 20	20x3	20	14,0	14	50,8	71	23,8	55	35,0	21,0	M 10	0,50			
420	3/4"	GFS 402 SRE 25	25x4	25	17,0	17	50,8	71	23,8	55	35,0	21,0	M 10	0,53			
420	1"	GFS 403 SRE 25	25x4	25	17,0	17	57,2	81	27,8	65	42,0	25,0	M 12	0,76			
420	1"	GFS 403 SRE 30	30x4	30	22,0	22	57,2	81	27,8	65	42,0	25,0	M 12	0,80			
420	1 1/4"	GFS 404 SRE 30	30x4	30	22,0	22	66,6	95	31,8	78	44,0	25,0	M 14	0,97			
420	1 1/4"	GFS 404 SRE 30-M12	30x4	30	22,0	22	66,6	95	31,8	78	44,0	25,0	M 12	1,09			
420	1 1/4"	GFS 404 SRE 38	38x6	38	26,0	26	66,6	95	31,8	78	44,0	25,0	M 14	1,08			
420	1 1/4"	GFS 404 SRE 38-M12	38x6	38	26,0	26	66,6	95	31,8	78	44,0	25,0	M 12	1,10			
420	1 1/2"	GFS 405 SRE 38	38x6	38	26,0	26	79,3	112	36,5	94	56,0	28,0	M 16	1,52			
420	1 1/2"	GFS 405 SRE 48	48,3x8	49	32,0	32	79,3	112	36,5	94	56,0	28,0	M 16	1,57			
420	1 1/2"	GFS 405 SRE 60	60,3x10	61	40,0	38	79,3	112	36,5	94	56,0	28,0	M 16	1,65			
420	2"	GFS 406 SRE 60	60,3x10	61	40,0	40	96,8	134	44,5	114	65,0	37,0	M 20	2,45			
420	2"	GFS 406 SRE 76	76,1x12,5	77	51,0	48	96,8	134	44,5	114	80,0	33,0	M 20	2,96			

*1 oder vergleichbare Güte / or comparable material

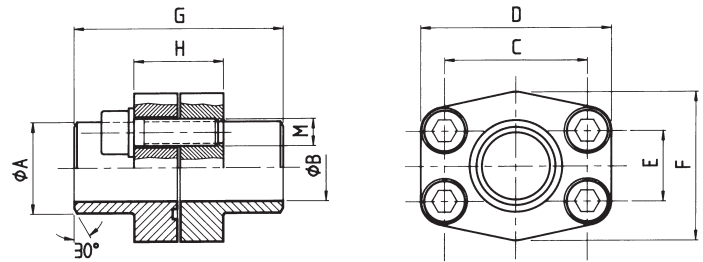

Bestellbezeichnung: ordering code:	S355J2^{*1}	1.4404^{*1} 316L
• Flansch mit metrischen Schraubensatz und O-Ring flange with metric bolts and o-ring	DFS-...STM	DFX-...STM
• Flansch mit UNC-Schraubensatz und O-Ring flange with UNC bolts and o-ring	DFS-...STU	DFX-...STU

* Der angeführte maximale Betriebsdruck ist bezogen auf den Flansch! Der tatsächliche Betriebsdruck wird bestimmt durch das Rohr (Wandstärke) sowie die Güte des Rohres!
The maximum recommended working pressure is based on the flange. The working pressure of the system is determined by the tube (thickness) and by the steel quality of the tube!

maximaler Betriebsdruck* maximum recommended working pressure	S.A.E. Baugröße nominal flange size	Typ type	Abmessungen dimensions								Schrauben bolts		Gewicht weight	
			A	B	C	D	E	F	G	H	M	kg		
kg/cm ²	inch													
Schraube Festigkeitskl. 10.9			Standarddruckreihe / Standard pressure									<i>metr.</i>	<i>unc.</i>	
350	1/2"	DFS 080 ST	21,5	13,0	38,1	54	17,5	46	72	32	M 8x30	5/16 x 1 1/4	0,56	
350	1/2"	DFS 080 ST-038	17,5	10,0	38,1	54	17,5	46	72	32	M 8x30	5/16 x 1 1/4	0,50	
350	3/4"	DFS 100 ST	28,0	19,0	47,6	65	22,3	50	72	36	M 10x40	3/8 x 1 1/2	0,78	
320	1"	DFS 102 ST	34,0	25,0	52,4	70	26,2	55	76	36	M 10x40	3/8 x 1 1/2	0,92	
280	1 1/4"	DFS 104 ST	42,8	32,0	58,7	79	30,2	68	82	42	M 10x45	7/16 x 1 1/2	1,32	
210	1 1/2"	DFS 106 ST	48,6	38,0	69,9	93	35,7	78	88	50	M 12x50	1/2 x 1 3/4	2,10	
210	2"	DFS 108 ST	61,0	51,0	77,8	102	42,9	90	90	50	M 12x50	1/2 x 1 3/4	2,38	
175	2 1/2"	DFS 110 ST	77,0	63,0	88,9	114	50,8	105	100	50	M 12x50	1/2 x 1 3/4	2,80	
160	3"	DFS 112 ST	92,0	73,0	106,4	134	61,9	124	100	54	M 16x55	5/8 x 2	4,30	
35	3 1/2"	DFS 114 ST	103,0	89,0	120,7	152	69,9	136	96	54	M 16x55	5/8 x 2	4,80	
35	4"	DFS 116 ST	115,5	99,0	130,2	162	77,8	146	96	54	M 16x55	5/8 x 2	5,70	
35	5"	DFS 118 ST	140,2	120,0	152,4	184	92,1	180	100	56	M 16x60	5/8 x 2	10,00	
Schraube Festigkeitskl. 10.9			Hochdruckreihe / High pressure									<i>metr.</i>	<i>unc.</i>	
420	1/2"	DFS 401 ST-012	21,5	13,0	40,5	54	18,2	46	72	32	M 8x30	5/16 x 1 1/4	0,58	
420	1/2"	DFS 401 ST-038	17,5	10,0	40,5	54	18,2	46	72	32	M 8x30	5/16 x 1 1/4	0,52	
420	3/4"	DFS 402 ST	28,0	19,0	50,8	71	23,8	55	70	42	M 10x45	3/8 x 1 1/2	1,00	
420	1"	DFS 403 ST	34,0	25,0	57,2	79	27,8	68	82	42	M 12x45	7/16 x 1 3/4	1,52	
375	1 1/4"	DFS 404 ST	42,8	32,0	66,6	93	31,8	78	88	50	M 14x50	–	2,40	
375	1 1/4"	DFS 404 ST-M12	42,8	32,0	66,6	93	31,8	78	88	50	M 12x45	1/2 x 1 3/4	2,40	
420	1 1/4"	DFS 404 ST 160	42,8	29,0	66,6	93	31,8	78	88	50	M 14x50	–	2,80	
420	1 1/4"	DFS 404 ST 160-M12	42,8	29,0	66,6	93	31,8	78	88	50	M 12x45	1/2 x 1 3/4	2,80	
250	1 1/2"	DFS 405 ST	48,6	38,0	79,3	114	36,5	94	110	60	M 16x60	5/8 x 2	3,30	
420	1 1/2"	DFS 405 ST 160	48,6	34,0	79,3	114	36,5	94	110	60	M 16x60	5/8 x 2	4,00	
250	2"	DFS 406 ST	61,0	51,0	96,8	134	44,5	114	130	74	M 20x75	3/4 x 2 1/2	4,90	
420	2"	DFS 406 ST 160	61,0	43,0	96,8	134	44,5	114	130	74	M 20x75	3/4 x 2 1/2	5,50	
420	2 1/2"	DFS 407 ST 76	76,1	51,0	123,8	180	58,8	152	160	90	M 24x90	–	12,80	
420	2 1/2"	DFS 407 ST 88	88,9	60,5	123,8	180	58,8	152	160	90	M 24x90	–	16,60	

*1 oder vergleichbare Güte / or comparable material

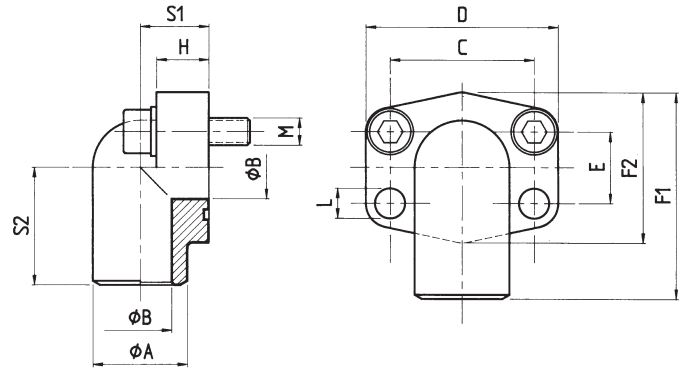

Bestellbezeichnung: ordering code:	S355J2 ^{*1}
• nur Flansch flange only	AFS-.../90ST
• incl. metrischem Schraubensatz und O-Ring including metric bolts and o-ring	AFS-.../90STM

* Der angeführte maximale Betriebsdruck ist bezogen auf den Flansch! Der tatsächliche Betriebsdruck wird bestimmt durch das Rohr (Wandstärke) sowie die Güte des Rohres!
The maximum recommended working pressure is based on the flange. The working pressure of the system is determined by the tube (thickness) and by the steel quality of the tube!

maximaler Betriebsdruck * maximum recommended working pressure	S.A.E. Baugröße nominal flange size	Typ type	Abmessungen dimensions											Schrauben bolts		Gewicht weight			
			A	B	C	D	E	F1	F2	H	L	S1	S2	M	kg				
kg/cm ²	inch																metr.	unc.	
Schraube Festigkeitskl.		Standarddruckreihe / Standard pressure																	
10.9																			
350	¾"	AFS 200/90 ST	27,0	19	47,6	70	22,3	63	50	21,0	11,0	23,0	41	M 10x40	–	0,65			
320	1"	AFS 202/90 ST	34,5	23	52,4	75	26,2	72	60	24,0	11,0	25,0	48	M 10x45	–	0,85			
280	1¼"	AFS 204/90 ST	43,0	31	58,7	86	30,2	82	68	25,0	11,5	27,0	54	M 10x45	–	1,15			
210	1½"	AFS 206/90 ST	50,0	35	69,9	97	35,7	92	78	29,0	14,0	31,5	57	M 12x50	–	1,70			
210	2"	AFS 208/90 ST	65,0	48	77,8	100	42,9	99	90	50,0	14,0	37,5	63	M 12x70	–	2,15			

*1 oder vergleichbare Güte / or comparable material

*2 anschweißfase V-Naht / welding nose v-seam

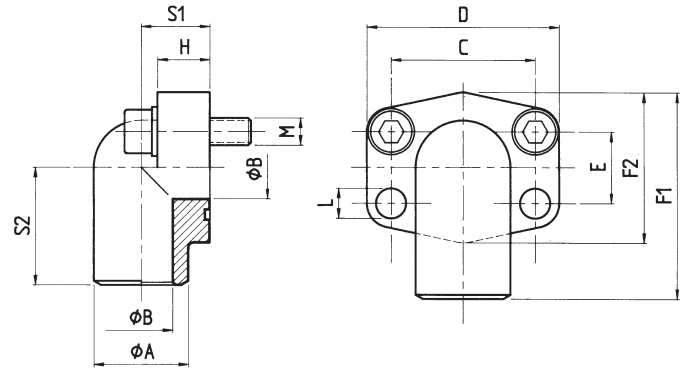

Bestellbezeichnung: ordering code:	S355J2*1
• nur Flansch flange only	AFS-.../90ST
• incl. metrischem Schraubensatz und O-Ring including metric bolts and o-ring	AFS-.../90STM

* Der angeführte maximale Betriebsdruck ist bezogen auf den Flansch! Der tatsächliche Betriebsdruck wird bestimmt durch das Rohr (Wandstärke) sowie die Güte des Rohres!
The maximum recommended working pressure is based on the flange. The working pressure of the system is determined by the tube (thickness) and by the steel quality of the tube!

maximaler Betriebsdruck * maximum recommended working pressure	S.A.E. Baugröße nominal flange size	Typ type	Abmessungen dimensions												Schrauben bolts		Gewicht weight		
			A	B	C	D	E	F1	F2	H	L	S1	S2	M	kg				
kg/cm ²	inch																metr.	unc.	
Schraube Festigkeitskl. 10.9	Hochdruckreihe / High pressure																		
420	¾"	AFS 700/90 ST	28,0	19	50,8	71	23,8	70	60	19,0	11,0	22,0	40	M 10x35	–	0,50			
420	1"	AFS 702/90 ST	34,0	25	57,2	81	27,8	82	70	24,0	13,0	27,0	47	M 12x45	–	0,80			
420	1"	AFS 702/90 ST-30x4*2	30,0	22	57,2	81	27,8	83	70	24,0	13,0	27,0	48	M 12x45	–	0,88			
375	1¼"	AFS 704/90 ST	42,0	32	66,6	95	31,8	95	78	27,0	15,0	32,0	56	M 14x50	–	1,15			
320	1½"	AFS 706/90 ST	48,0	38	79,3	113	36,5	115	94	30,0	17,0	40,0	68	M 16x50	–	2,00			

*1 oder vergleichbare Güte / or comparable material

*2 anschweißfase V-Naht / welding nose v-seam

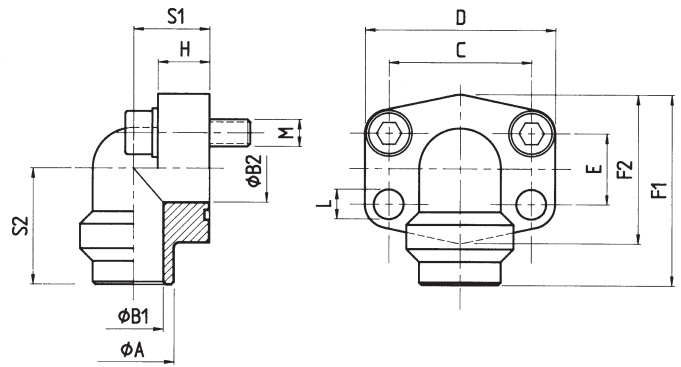

Bestellbezeichnung: <i>ordering code:</i>	S355J2^{*1}	1.4404^{*1} 316L
• nur Flansch <i>flange only</i>	AFS-...	AFX-...
• incl. metrischem Schraubensatz und O-Ring <i>including metric bolts and o-ring</i>	AFS-...M	AFX-...MX
• incl. UNC-Schraubensatz und O-Ring <i>including UNC bolts and o-ring</i>	AFS-...U	AFX-...UX

* Der angeführte maximale Betriebsdruck ist bezogen auf den Flansch! Der tatsächliche Betriebsdruck wird bestimmt durch das Rohr (Wandstärke) sowie die Güte des Rohres!
The maximum recommended working pressure is based on the flange. The working pressure of the system is determined by the tube (thickness) and by the steel quality of the tube!

maximaler Betriebsdruck * <i>maximum recommended working pressure</i>	S.A.E. Baugröße <i>nominal flange size</i>	Typ <i>type</i>	Abmessungen <i>dimensions</i>													Schrauben <i>bolts</i>		Gewicht <i>weight</i>
			Rohr/ tube	A	B1	B2	C	D	E	F1	F2	H	S1	S2	L	M	kg	
kg/cm ²	inch																	
Schraube Festigkeitskl.																		
10.9	Standarddruckreihe / Standard pressure															<i>metr.</i>	<i>unc.</i>	
250	1/2"	AFS 080/90 SRE 20	20x3	20,0	14	13	38,1	54	17,5	60	48	16	20	37	9,0	M 8x30	5/16 x 1 1/4	0,33
160	1/2"	AFS 080/90 SRE 22	22x2	22,0	18	13	38,1	54	17,5	60	48	16	20	37	9,0	M 8x30	5/16 x 1 1/4	0,34
250	1/2"	AFS 080/90 SRE 25	25x3	25,0	19	13	38,1	54	17,5	60	48	16	20	37	9,0	M 8x30	5/16 x 1 1/4	0,35
160	1/2"	AFS 080/90 SRE 28	28x3	28,0	22	13	38,1	54	17,5	60	48	16	20	37	9,0	M 8x30	5/16 x 1 1/4	0,36
250	3/4"	AFS 100/90 SRE 25	25x3	25,0	19	19	47,6	65	22,3	63	50	18	24	38	11,0	M 10x35	3/8 x 1 1/2	0,49
160	3/4"	AFS 100/90 SRE 28	28x3	28,0	22	19	47,6	65	22,3	63	50	18	24	38	11,0	M 10x35	3/8 x 1 1/2	0,50
250	3/4"	AFS 100/90 SRE 30	30x4	30,0	22	19	47,6	65	22,3	63	50	18	24	38	11,0	M 10x35	3/8 x 1 1/2	0,51
160	3/4"	AFS 100/90 SRE 35	35x4	35,0	27	19	47,6	65	22,3	63	50	18	24	38	11,0	M 10x35	3/8 x 1 1/2	0,55
250	1"	AFS 102/90 SRE 30	30x4	30,0	22	25	52,4	70	26,2	70	60	19	28	43	11,0	M 10x35	3/8 x 1 1/2	0,70
160	1"	AFS 102/90 SRE 35	35x4	35,0	27	25	52,4	70	26,2	70	60	19	28	43	11,0	M 10x35	3/8 x 1 1/2	0,73
250	1"	AFS 102/90 SRE 38	38x4	38,0	30	25	52,4	70	26,2	70	60	19	28	43	11,0	M 10x35	3/8 x 1 1/2	0,76
160	1"	AFS 102/90 SRE 42	42x3	42,0	36	25	52,4	70	26,2	70	60	19	28	43	11,0	M 10x35	3/8 x 1 1/2	0,80
280	1 1/4"	AFS 104/90 SRE 38	38x4	38,0	30	32	58,7	79	30,2	85	68	21	34	51	11,5	M 10x40	7/16 x 1 1/2	1,20
160	1 1/4"	AFS 104/90 SRE 42	42x3	42,0	36	32	58,7	79	30,2	85	68	21	34	51	11,5	M 10x40	7/16 x 1 1/2	1,24
160	1 1/4"	AFS 104/90 SRE 48,3	48,3x4,5	49,0	39	32	58,7	79	30,2	85	68	21	34	51	11,5	M 10x40	7/16 x 1 1/2	1,30
210	1 1/2"	AFS 106/90 SRE 38	38x4	38,0	30	38	69,9	93	35,7	95	78	25	38	56	13,5	M 12x45	1/2 x 1 3/4	1,50
160	1 1/2"	AFS 106/90 SRE 42	42x3	42,0	36	38	69,9	93	35,7	95	78	25	38	56	13,5	M 12x45	1/2 x 1 3/4	1,53
160	1 1/2"	AFS 106/90 SRE 48,3	48,3x4,5	49,0	39	38	69,9	93	35,7	95	78	25	38	56	13,5	M 12x45	1/2 x 1 3/4	1,60
210	2"	AFS 108/90 SRE 60,3	60,3x5,6	61,0	49	51	77,8	110	42,9	110	90	25	42	65	13,5	M 12x45	1/2 x 1 3/4	1,93
210	2"	AFS 108/90 SRE 76,1	76,1x7,1	73,0	62	51	77,8	110	42,9	110	90	25	42	65	13,5	M 12x45	1/2 x 1 3/4	2,00
175	2 1/2"	AFS 110/90 SRE 76,1	76,1x7,1	76,1	57	60	88,9	115	50,8	127	96	25	50	77	13,5	M 12x45	1/2 x 1 3/4	-

*1 oder vergleichbare Güte /
or comparable material

Hinweis: Der angegebene Nenndruck ist nach der SAE J 518 C durch den Flansch bzw. nach dem anzuschweißenden Rohr festgelegt. /
Please note: The maximum working pressure is fixed by SAE J 518 C on flange side or by the used tube.

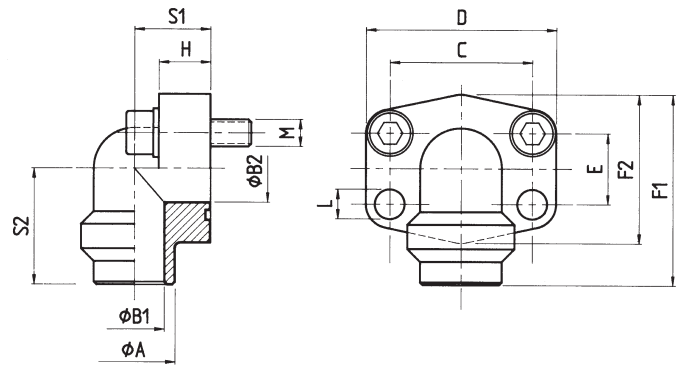

Bestellbezeichnung: ordering code:	S355J2^{*1}	1.4404^{*1} 316L
• nur Flansch flange only	AFS-...	AFX-...
• incl. metrischem Schraubensatz und O-Ring including metric bolts and o-ring	AFS-...M	AFX-...MX
• incl. UNC-Schraubensatz und O-Ring including UNC bolts and o-ring	AFS-...U	AFX-...UX

* Der angeführte maximale Betriebsdruck ist bezogen auf den Flansch! Der tatsächliche Betriebsdruck wird bestimmt durch das Rohr (Wandstärke) sowie die Güte des Rohres!
 The maximum recommended working pressure is based on the flange. The working pressure of the system is determined by the tube (thickness) and by the steel quality of the tube!

maximaler Betriebsdruck * maximum recommended working pressure	S.A.E. Baugröße nominal flange size	Typ type	Abmessungen dimensions													Schrauben bolts		Gewicht weight			
			Rohr/tube	A	B1	B2	C	D	E	F1	F2	H	S1	S2	L	M	unc.		kg		
kg/cm ²	inch																		metr.	unc.	kg
Schraube Festigkeitskl.			Hochdruckreihe / High pressure																		
10.9																		metr.	unc.		
315	1/2"	AFS 401/90 SRE 20	20x3	20	14	13	40,5	56,4	18,2	60	48	16,0	20	37	9,0	M 8x30	5/16 x 1 1/4	0,35			
315	1/2"	AFS 401/90 SRE 25	25x4	25	17	13	40,5	56,4	18,2	60	48	16,0	20	37	9,0	M 8x30	5/16 x 1 1/4	0,36			
315	3/4"	AFS 402/90 SRE 25	25x4	25	17	19	50,8	71,3	23,8	70	60	19,0	28	43	11,0	M 10x35	3/8 x 1 1/2	0,74			
315	3/4"	AFS 402/90 SRE 30	30x4	30	22	19	50,8	71,3	23,8	70	60	19,0	28	43	11,0	M 10x35	3/8 x 1 1/2	0,80			
320	1"	AFS 403/90 SRE 30	30x4	30	22	25	57,2	81,0	27,8	85	70	21,0	34	51	13,0	M 12x45	7/16 x 1 3/4	1,25			
320	1"	AFS 403/90 SRE 38	38x5	38	28	25	57,2	81,0	27,8	85	70	21,0	34	51	13,0	M 12x45	7/16 x 1 3/4	1,30			
315	1 1/4"	AFS 404/90 SRE 38	38x5	38	28	32	66,6	95,2	31,8	95	78	25,0	38	56	14,5	M 14x50	–	1,52			
315	1 1/4"	AFS 404/90 SRE 48,3	48,3x8	49	32	32	66,6	95,2	31,8	95	78	25,0	38	56	14,5	M 14x50	–	1,60			
315	1 1/2"	AFS 405/90 SRE 38	38x5	38	28	38	79,3	110,0	36,5	110	94	25,0	42	65	17,0	M 16x50	5/8 x 2	1,84			
315	1 1/2"	AFS 405/90 SRE 48,3	48,3x8	49	32	38	79,3	110,0	36,5	110	94	25,0	42	65	17,0	M 16x50	5/8 x 2	1,92			
315	1 1/2"	AFS 405/90 SRE 50x6 ^{*2}		50	38	38	79,3	110,0	36,5	108	85	30,0	47	63	17,0	M 16x55		2,47			
315	1 1/2"	AFS 405/90 SRE 50x7 ^{*2}		50	36	38	79,3	112,0	36,5	112	85	30,0	47	66	17,0	M 16x55		2,66			
315	1 1/2"	AFS 405/90 SRE 60,3	60,3x10	61	40	38	79,3	110,0	36,5	110	94	25,0	42	65	17,0	M 16x50	5/8 x 2	2,00			
315	2"	AFS 406/90 SRE 60,3	60,3x10	61	40	51	96,8	136,0	44,5	133	108	35,0	45	75	21,0	M 20x70	–	4,20			
315	2"	AFS 406/90 SRE 76,1	76,1x12,5	76	50	51	96,8	134,0	44,5	132	107	35,0	45	75	21,0	M 20x70	–	3,84			

*1 oder vergleichbare Güte / or comparable material
 *2 anschweißfase V-Naht / welding nose v-seam

Hinweis: Der angegebene Nenndruck ist nach der SAE J 518 C durch den Flansch bzw. nach dem anzuschweißenden Rohr festgelegt. / **Please note:** The maximum working pressure is fixed by SAE J 518 C on flange side or by the used tube.

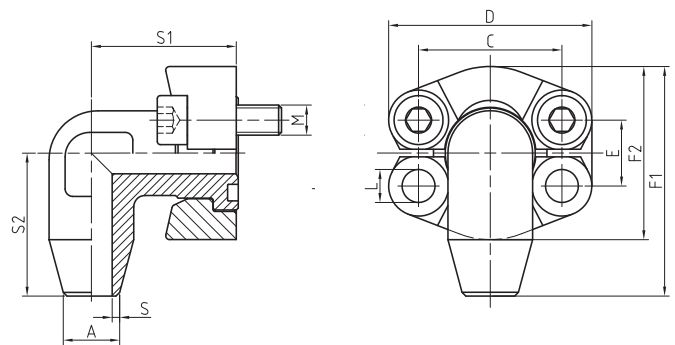

Bestellbezeichnung: ordering code:	S355J2^{*1}	1.4404^{*1} 316L
• nur 90° Zwischenstück only 90° elbow	WFS-...	WFS-X-...
• incl. Flanschhälften, Schraubensatz (metrisch) und O-Ring including split flanges, metric bolts and o-ring	WFS-...M	WFS-X-...MX
• incl. Flanschhälften, UNC-Schraubensatz und O-Ring including split flanges, UNC bolts and o-ring	WFS-...U	WFS-X-...UX

* Der angeführte maximale Betriebsdruck ist bezogen auf den Flansch! Der tatsächliche Betriebsdruck wird bestimmt durch das Rohr (Wandstärke) sowie die Güte des Rohres!
The maximum recommended working pressure is based on the flange. The working pressure of the system is determined by the tube (thickness) and by the steel quality of the tube!

maximaler Betriebsdruck * maximum recommended working pressure	S.A.E. Baugröße nominal flange size	Typ type	Abmessungen dimensions						Schrauben bolts		Gewicht weight
			C	D	E	F1/F2	S1/S2	L	M		
kg/cm ²	inch										kg
Schraube Festigkeitskl. 10.9		Standarddruckreihe / Standard pressure							metr.	unc.	
350	1/2"	WFS-3001	38,1	54	17,5	60,8/45,6	39/38	8,75	M 8x25	5/16 x 1 1/4	–
			A x S = 15 x 2 – 16 x 2 – 21,3 x 3,8								
350	3/4"	WFS-3002	47,6	65	22,3	70,9/51,8	42/45	10,75	M 10x30	3/8 x 1 1/4	–
			A x S = 18 x 1,5 – 20 x 3 – 22 x 3 – 25 x 3 – 26,9 x 3,9								
320	1"	WFS-3003	52,4	70	26,2	79,2/58,4	45/50	10,75	M 10x30	3/8 x 1 1/4	–
			A x S = 25 x 3 – 30 x 4 – 33,7 x 4,5								
280	1 1/4"	WFS-3004	58,7	79	30,2	85,3/72,6	50/59	10,75/12,75	M 10x30 M 12x35	7/16 x 1 1/2	–
			A x S = 25 x 3 – 30 x 4 – 35 x 2 – 38 x 5 – 42,4 x 5								
210	1 1/2"	WFS-3005	69,9	94	35,7	117,1/82,2	76/56	13,5	M 12x35	1/2 x 1 1/2	–
			A x S = 38 x 5 – 42 x 3 – 48,3 x 5								
210	2"	WFS-3006	77,8	101,6	42,9	128,4/ 96,8	108/80	13,3	M 12x35	1/2 x 1 1/2	–
			A x S = 60,3 x 3,9 – 60,3 x 5,6								
Schraube Festigkeitskl. 10.9		Hochdruckreihe / High pressure							metr.	unc.	
420	1/2"	WFS-6001	40,5	56	18,2	61,6/47,2	39/38	8,75	M 8x30	5/16 x 1 1/4	–
			A x S = 16 x 3 – 21,3 x 4,5								
420	3/4"	WFS-6002	50,8	71	23,8	78/60	48/48	10,75	M 10x35	3/8 x 1 1/2	–
			A x S = 16 x 3 – 20 x 4 – 25 x 4 – 26,9 x 5,6								
420	1"	WFS-6003	57,2	81	27,8	94/69,6	60/60	12,0/13,0	M 12x45	7/16 x 1 3/4	–
			A x S = 25 x 4 – 30 x 4 – 33,7 x 4,5 – 33,7 x 6,3								
315	1 1/4"	WFS-6004	66,6	95	31,8	106,6/77,2	68/68	13,5/14,75	M 14x50	1/2 x 1 3/4	–
			A x S = 30 x 4 – 38 x 5 – 42,4 x 6,3 – 38 x 8 ^{*2}								
315	1 1/2"	WFS-6005	79,3	113	36,5	123,5/95	76/76	16,8	M 16x55	5/8 x 2	–
			A x S = 38 x 5 – 38 x 8 ^{*2} – 48,3 x 7,14 – 48,3 x 8								
420	2"	WFS-6006	96,8	133,4	44,5	137,2/114,3	108/80	21	M 20x70	3/4 x 2 1/2	–
			A x S = 60,3 x 8 – 60,3 x 8,7 – 60,3 x 10								

*1 oder vergleichbare Güte / or comparable material

*2 Rohrabmessung 38x8 für max. Betriebsdruck 350/400 einsetzbar / Implemented pipe dimensions 38x8 for max. working pressure 350/400

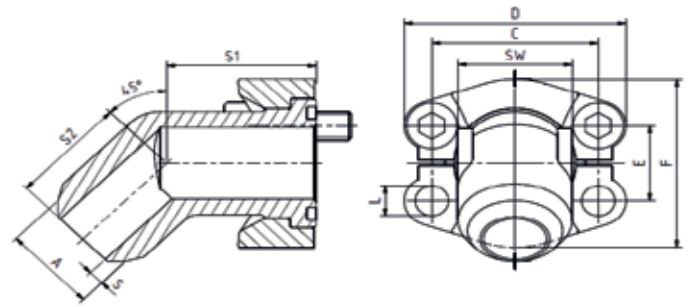

Bestellbezeichnung: ordering code:	S355J2^{*1}	1.4404^{*1}
• nur 45° Flansch-Adapter only 45° flange-adapter	WFS-...-45-...	WFS-X-...-45-...
• incl. Flanschhälften, Schraubensatz und O-Ring including split flanges, bolts and o-ring	WFS-...-45-...M	WFS-X-...-45-... MX

maximaler Betriebsdruck * maximum recommended working pressure	S.A.E. Baugröße nominal flange size	Typ type	Abmessungen dimensions									Schrauben bolts	Gewicht weight	
			C	D	E	F	L	S1	S2	SW	M			kg
kg/cm ²	inch													
Schraube Festigkeitskl. 10.9	Standarddruckreihe / Standard pressure													
350	1/2"	WFS-3001-45	38,1	54	17,5	46	8,5	39	32,5	24	M8x25	-		
			AxS = 15x2 - 16x2 - 21,3x3,8											
350	3/4"	WFS-3002-45	47,6	65	22,2	52	10,5	40,15	32,5	30	M10x30	-		
			AxS = 18x1,5 - 20x3 - 22x3 - 25x3 - 26,9x3,9											
320	1"	WFS-3003-45	52,4	70	26,2	59	10,5	47	37,35	36	M10x30	-		
			AxS = 25x3 - 30x4 - 33,7x4,5											
280	1 1/4"	WFS-3004-45	58,7	79	30,2	73	*2	51,8	40,4	41	*3	-		
			AxS = 25x3 - 30x4 - 35x2 - 38x5 - 42,4x5											
210	1 1/2"	WFS-3005-45	69,9	94	35,7	83	13,3	60,45	45,2	50	M12x35	-		
			AxS = 38x5 - 42x3 - 48,3x5											
Schraube Festigkeitskl. 10.9	Hochdruckreihe / High pressure													
420	1/2"	WFS-6001-45	40,5	56,4	18,2	47,8	8,5	39	32,5	24	M8x30	-		
			AxS = 16x3 - 21,3x4,5											
420	3/4"	WFS-6002-45	50,8	71	23,8	61	10,5	40,15	32,5	32	M10x35	-		
			AxS = 16x3 - 20x4 - 25x4 - 26,9x5,6											
420	1"	WFS-6003-45	57,2	81	27,8	70	13,3	47	37,35	41	M12x45	-		
			AxS = 25x4 - 30x4 - 33,7x4,5 - 33,7x6,3											
315	1 1/4"	WFS-6004-45	66,7	95	31,8	78	*4	51,8	40,4	46	*5	-		
			AxS = 30x4 - 38x5 - 42,4x6,3 - 38x8*6											
315	1 1/2"	WFS-6005-45	79,4	113	36,5	95	16,8	60,45	45,2	50	M16x55	-		
			AxS = 38x5 - 38x8*6 - 48,3x7,14 - 48,3x8											

*1 oder vergleichbare Güte / or comparable material

*2 Schraubenbohrung 10,5; 12,0; 12,75 / bolt hole 10,75; 12,0; 12,75

*3 M10x30 oder M12x35

*4 Schraubenbohrung 14,6 oder 13,3

*5 M14x50 oder M12x45

*6 Rohrabmessung 38x8 für max. Betriebsdruck 420 einsetzbar

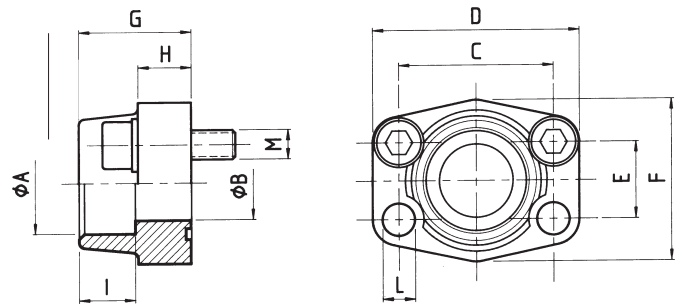
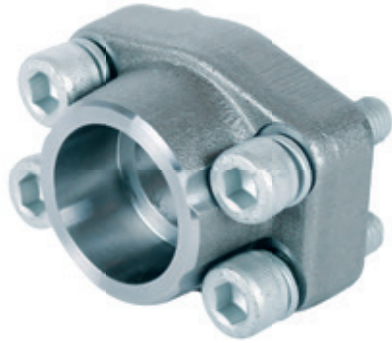

Bestellbezeichnung: ordering code:	S355J2^{*1}	1.4404^{*1} 316L
• nur Flansch flange only	AFS-...S	AFX-...S
• incl. metrischem Schraubensatz und O-Ring including metric bolts and o-ring	AFS-...SM	AFX-...SMX
• incl. UNC Schraubensatz und O-Ring including UNC bolts and o-ring	AFS-...SU	AFX-...SUX

maximaler Betriebsdruck maximum recommended working pressure	S.A.E. Baugröße nominal flange size	Typ type	Abmessungen dimensions										Schrauben bolts		Gewicht weight
			A	B	C	D	E	F	G	H	I	L	M	kg	
kg/cm ²	inch														
Schraube Festigkeitskl. 10.9	Standarddruckreihe / Standard pressure												metr.	unc.	
350	1/2"	AFS 080 S	21,6	13	38,1	54	17,5	46	36	16	19	9,0	M 8x30	5/16 x 1 1/4	0,25
350	1/2"	AFS 080 S-038	17,5	13	38,1	54	17,5	46	36	16	19	9,0	M 8x30	5/16 x 1 1/4	0,28
350	1/2"	AFS 080 S A20	20,3	13	38,1	54	17,5	46	36	16	19	9,0	M 8x30	5/16 x 1 1/4	0,25
350	3/4"	AFS 100 S	27,2	19	47,6	65	22,3	50	36	18	19	11,0	M 10x35	3/8 x 1 1/2	0,39
350	3/4"	AFS 100 S A25	25,3	19	47,6	65	22,3	50	36	18	19	11,0	M 10x35	3/8 x 1 1/2	0,39
320	1"	AFS 102 S	34,0	25	52,4	70	26,2	55	38	18	19	11,0	M 10x35	3/8 x 1 1/2	0,46
320	1"	AFS 102 S A30	30,3	25	52,4	70	26,2	55	38	18	19	11,0	M 10x35	3/8 x 1 1/2	0,46
280	1 1/4"	AFS 104 S	42,8	32	58,7	79	30,2	68	41	21	22	11,5	M 10x40	7/16 x 1 1/2	0,66
280	1 1/4"	AFS 104 S A38	38,3	32	58,7	79	30,2	68	41	21	22	11,5	M 10x40	7/16 x 1 1/2	0,66
210	1 1/2"	AFS 106 S	48,6	38	69,9	93	35,7	78	45	25	24	13,5	M 12x45	1/2 x 1 3/4	1,05
210	1 1/2"	AFS 106 S A50	50,5	38	69,9	93	35,7	78	45	25	24	13,5	M 12x45	1/2 x 1 3/4	1,05
210	2"	AFS 108 S	61,0	51	77,8	102	42,9	90	45	25	26	13,5	M 12x45	1/2 x 1 3/4	1,19
175	2 1/2"	AFS 110 S	76,6	63	88,9	114	50,8	105	50	25	30	13,5	M 12x45	1/2 x 1 3/4	1,40
160	3"	AFS 112 S	90,5	73	106,4	134	61,9	124	50	27	34	17,5	M 16x50	5/8 x 2	2,15
35	3 1/2"	AFS 114 S	103,0	89	120,7	152	69,9	136	48	27	34	17,5	M 16x50	5/8 x 2	2,40
35	4"	AFS 116 S	115,5	99	130,2	162	77,8	146	48	27	34	17,5	M 16x50	5/8 x 2	2,85
35	5"	AFS 118 S	142,0	120	152,4	184	92,1	181	50	28	28	17,5	M 16x55	5/8 x 2	5,80

*1 oder vergleichbare Güte / or comparable material

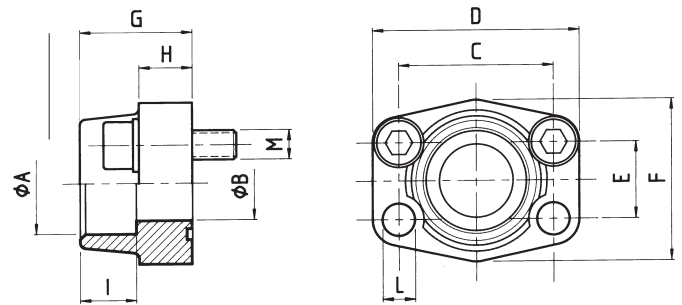

Bestellbezeichnung: ordering code:	S355J2^{*1}	1.4404^{*1} 316L
• nur Flansch flange only	AFS-...S	AFX-...S
• incl. metrischem Schraubensatz und O-Ring including metric bolts and o-ring	AFS-...SM	AFX-...SMX
• incl. UNC Schraubensatz und O-Ring including UNC bolts and o-ring	AFS-...SU	AFX-...SUX

maximaler Betriebsdruck maximum recommended working pressure	S.A.E. Baugröße nominal flange size	Typ type	Abmessungen dimensions										Schrauben bolts		Gewicht weight
			A	B	C	D	E	F	G	H	I	L	M	kg	
kg/cm ²	inch												metr.	unc.	kg
Schraube Festigkeitskl. 10.9	Hochdruckreihe / High pressure														
420	1/2"	AFS 401 S-012	21,6	13	40,5	54	18,2	46	36	16	19	9,0	M 8x30	5/16 x 1 1/4	0,26
420	1/2"	AFS 401 S-038	17,5	13	40,5	54	18,2	46	36	16	19	9,0	M 8x30	5/16 x 1 1/4	0,29
420	1/2"	AFS 401 S A20	20,3	13	40,5	54	18,2	46	36	16	19	9,0	M 8x30	5/16 x 1 1/4	0,26
420	3/4"	AFS 402 S	27,2	19	50,8	71	23,8	55	35	21	22	11,0	M 10x35	3/8 x 1 1/2	0,50
420	3/4"	AFS 402 S A25	25,3	19	50,8	71	23,8	55	35	21	22	11,0	M 10x35	3/8 x 1 1/2	0,50
420	1"	AFS 403 S	34,0	25	57,2	81	27,8	65	42	25	22	13,0	M 12x45	7/16 x 1 3/4	0,76
420	1"	AFS 403 S A30	30,3	25	57,2	81	27,8	65	42	25	22	13,0	M 12x45	7/16 x 1 3/4	0,76
420	1 1/4"	AFS 404 S	42,8	32	66,6	95	31,8	78	45	27	25	15,0	M 14x50	–	1,20
420	1 1/4"	AFS 404 SL=13,5	42,8	32	66,6	95	31,8	78	45	27	25	13,5	M 12x45	1/2 x 1 3/4	1,12
420	1 1/4"	AFS 404 S A38	38,3	32	66,6	95	31,8	78	45	27	25	15,0	M 14x50	1/2 x 1 3/4	1,20
420	1 1/2"	AFS 405 S	48,6	38	79,3	112	36,5	94	50	30	28	17,5	M 16x50	5/8 x 2	1,65
420	1 1/2"	AFS 405 S A50	50,5	38	79,3	112	36,5	94	50	30	28	17,5	M 16x50	5/8 x 2	1,65
420	2"	AFS 406 S	61,0	51	96,8	134	44,5	114	65	37	24	21,0	M 20x70	3/4 x 2 1/2	2,45
420	2 1/2"	AFS 407 S	76,6	63	123,8	180	58,8	152	80	45	30	26,0	M 24x80	–	8,30
420	3"	AFS 408 S	90,5	73	152,4	208	71,6	178	90	55	33	33,0	M 30x90	–	11,81

*1 oder vergleichbare Güte / or comparable material

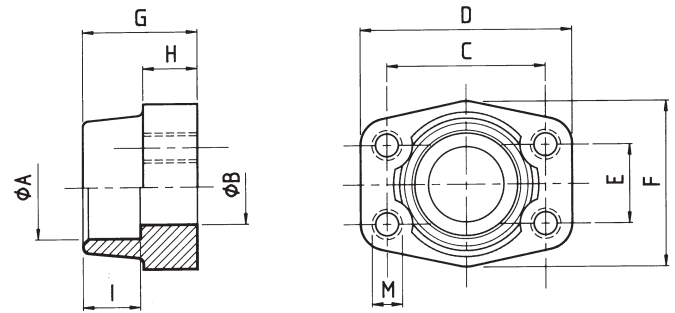

Bestellbezeichnung: ordering code:	S355J2^{*1}	1.4404^{*1} 316L
• Flansch mit metrischen Gewinden flange with metric threads	GFS-...SM	GFX-...SM
• Flansch mit UNC-Gewinden flange with UNC threads	GFS-...SU	GFX-...SU

maximaler Betriebsdruck maximum recommended working pressure	S.A.E. Baugröße nominal flange size	Typ type	Abmessungen dimensions									Gewinde thread		Gewicht weight
			A	B	C	D	E	F	G	H	I	M	kg	
kg/cm ²	inch													
Schraube Festigkeitskl. 10.9	Standarddruckreihe / Standard pressure											metr.	unc.	
350	1/2"	GFS 080 S	21,6	13	38,1	54	17,5	46	36	16	19	M 8	5/16	0,25
350	1/2"	GFS 080 S-038	17,5	13	38,1	54	17,5	46	36	16	19	M 8	5/16	0,28
350	1/2"	GFS 080 S-A20	20,3	13	38,1	54	17,5	46	36	16	19	M 8	5/16	0,25
350	3/4"	GFS 100 S	27,2	19	47,6	65	22,3	50	36	18	19	M 10	3/8	0,39
350	3/4"	GFS 100 S-A25	25,3	19	47,6	65	22,3	50	36	18	19	M 10	3/8	0,39
320	1"	GFS 102 S	34,0	25	52,4	70	26,2	55	38	18	19	M 10	3/8	0,46
320	1"	GFS 102 S-A30	30,3	25	52,4	70	26,2	55	38	18	19	M 10	3/8	0,46
280	1 1/4"	GFS 104 S	42,8	32	58,7	79	30,2	68	41	21	22	M 10	7/16	0,66
280	1 1/4"	GFS 104 S-A38	38,3	32	58,7	79	30,2	68	41	21	22	M 10	7/16	0,66
210	1 1/2"	GFS 106 S	48,6	38	69,9	93	35,7	78	45	25	24	M 12	1/2	1,05
210	1 1/2"	GFS 106 S-A50	50,5	38	69,9	93	35,7	78	45	25	24	M 12	1/2	1,05
210	2"	GFS 108 S	61,0	51	77,8	102	42,9	90	45	25	26	M 12	1/2	1,19
175	2 1/2"	GFS 110 S	76,6	63	88,9	114	50,8	105	50	25	30	M 12	1/2	1,40
160	3"	GFS 112 S	90,5	73	106,4	134	61,9	124	50	27	34	M 16	5/8	2,15
35	3 1/2"	GFS 114 S	103,0	89	120,7	152	69,9	136	48	27	34	M 16	5/8	2,40
35	4"	GFS 116 S	115,5	99	130,2	162	77,8	146	48	27	34	M 16	5/8	2,85
35	5"	GFS 118 S	142,0	120	152,4	184	92,1	181	50	28	28	M 16	5/8	5,80

*1 oder vergleichbare Güte / or comparable material

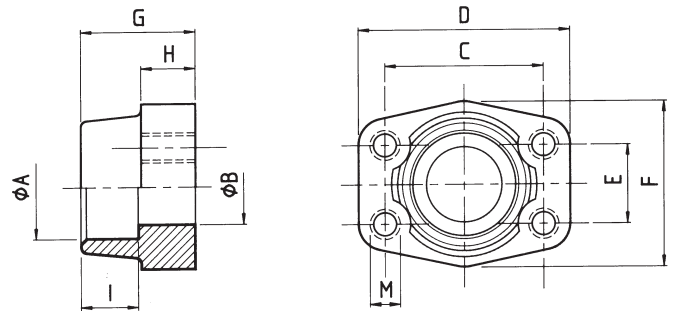

Bestellbezeichnung: ordering code:	S355J2^{*1}	1.4404^{*1} 316L
• Flansch mit metrischen Gewinden flange with metric threads	GFS-...SM	GFX-...SM
• Flansch mit UNC-Gewinden flange with UNC threads	GFS-...SU	GFX-...SU

maximaler Betriebsdruck maximum recommended working pressure	S.A.E. Baugröße nominal flange size	Typ type	Abmessungen dimensions									Gewinde thread		Gewicht weight	
			A	B	C	D	E	F	G	H	I	M	kg		
kg/cm ²	inch														
Schraube Festigkeitskl. 10.9	Hochdruckreihe / High pressure											metr.	unc.		
420	1/2"	GFS 401 S-012	21,6	13	40,5	54	18,2	46	36	16	19	M 8	5/16	0,26	
420	1/2"	GFS 401 S-038	17,5	13	40,5	54	18,2	46	36	16	19	M 8	5/16	0,29	
420	1/2"	GFS 401 S-A20	20,3	13	40,5	54	18,2	46	36	16	19	M 8	5/16	0,26	
420	3/4"	GFS 402 S	27,2	19	50,8	71	23,8	55	35	21	22	M 10	3/8	0,50	
420	3/4"	GFS 402 S-A25	25,3	19	50,8	71	23,8	55	35	21	22	M 10	3/8	0,50	
420	1"	GFS 403 S	34,0	25	57,2	81	27,8	65	42	25	22	M 12	7/16	0,76	
420	1"	GFS 403 S-A30	30,3	25	57,2	81	27,8	65	42	25	22	M 12	7/16	0,76	
420	1 1/4"	GFS 404 S	42,8	32	66,6	95	31,8	78	45	27	25	M 14	–	1,20	
420	1 1/4"	GFS 404 S-M12	42,8	32	66,6	95	31,8	78	45	27	25	M 12	1/2	1,20	
420	1 1/4"	GFS 404 S-A38	38,3	32	66,6	95	31,8	78	45	27	25	M 14	1/2	1,20	
420	1 1/2"	GFS 405 S	48,6	38	79,3	112	36,5	94	50	30	28	M 16	5/8	1,65	
420	1 1/2"	GFS 405 S-A50	50,5	38	79,3	112	36,5	94	50	30	28	M 16	5/8	1,65	
420	2"	GFS 406 S	61,0	51	96,8	134	44,5	114	65	37	24	M 20	3/4	2,45	
420	2 1/2"	GFS 407 S	76,6	63	123,8	180	58,8	152	80	45	30	M 24	–	8,30	
420	3"	GFS 408 S	90,5	73	152,4	208	71,6	178	90	55	33	M 30	–	12,29	

*1 oder vergleichbare Güte / or comparable material

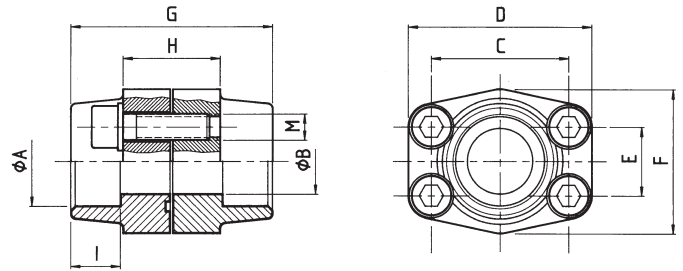

Bestellbezeichnung: ordering code:	S355J2^{*1}	1.4404^{*1} 316L
• Flansch mit metrischem Schraubensatz und O-Ring flange including metric bolts and o-ring	DFS-...SM	DFX-...SMX
• Flansch mit UNC-Schraubensatz und O-Ring flange with UNC bolts and o-ring	DFS-...SU	DFX-...SUX

maximaler Betriebsdruck maximum recommended working pressure	S.A.E. Baugröße nominal flange size	Typ type	Abmessungen dimensions									Schrauben bolts		Gewicht ohne Schrauben weight without bolts
			A	B	C	D	E	F	G	H	I	M	kg	
kg/cm ²	inch													
Schraube Festigkeitskl. 10.9	Standarddruckreihe / Standard pressure											metr.	unc.	
350	1/2"	DFS 080 S	21,6	13	38,1	54	17,5	46	72	32	19	M 8x30	5/16 x 1 1/4	0,50
350	1/2"	DFS 080 S-038	17,5	13	38,1	54	17,5	46	72	32	19	M 8x30	5/16 x 1 1/4	0,56
350	1/2"	DFS 080 S-A20	20,3	13	38,1	54	17,5	46	72	32	19	M 8x30	5/16 x 1 1/4	0,56
350	3/4"	DFS 100 S	27,2	19	47,6	65	22,3	50	72	36	19	M 10x40	3/8 x 1 1/2	0,78
350	3/4"	DFS 100 S-A25	25,3	19	47,6	65	22,3	50	72	36	19	M 10x40	3/8 x 1 1/2	0,78
320	1"	DFS 102 S	34,0	25	52,4	70	26,2	55	76	36	19	M 10x40	3/8 x 1 1/2	0,92
320	1"	DFS 102 S-A30	30,3	25	52,4	70	26,2	55	76	36	19	M 10x40	3/8 x 1 1/2	0,92
280	1 1/4"	DFS 104 S	42,8	32	58,7	79	30,2	68	82	42	22	M 10x45	7/16 x 1 1/2	1,32
280	1 1/4"	DFS 104 S-A38	38,3	32	58,7	79	30,2	68	82	42	22	M 10x45	7/16 x 1 1/2	1,32
210	1 1/2"	DFS 106 S	48,6	38	69,9	93	35,7	78	90	50	24	M 12x50	1/2 x 1 3/4	2,10
210	1 1/2"	DFS 106 S-A50	50,5	38	69,9	93	35,7	78	90	50	24	M 12x50	1/2 x 1 3/4	2,10
210	2"	DFS 108 S	61,0	51	77,8	102	42,9	90	90	50	26	M 12x50	1/2 x 1 3/4	2,38
175	2 1/2"	DFS 110 S	76,6	63	88,9	114	50,8	105	100	50	30	M 12x50	1/2 x 1 3/4	2,80
160	3"	DFS 112 S	90,5	73	106,4	134	61,9	124	100	54	34	M 16x55	5/8 x 2	4,30
35	3 1/2"	DFS 114 S	103,0	89	120,7	152	69,9	136	96	54	34	M 16x55	5/8 x 2	4,80
35	4"	DFS 116 S	115,5	99	130,2	162	77,8	146	96	54	34	M 16x55	5/8 x 2	5,70
35	5"	DFS 118 S	142,0	120	152,4	184	92,1	181	100	56	28	M 16x60	5/8 x 2	12,10

*1 oder vergleichbare Güte / or comparable material

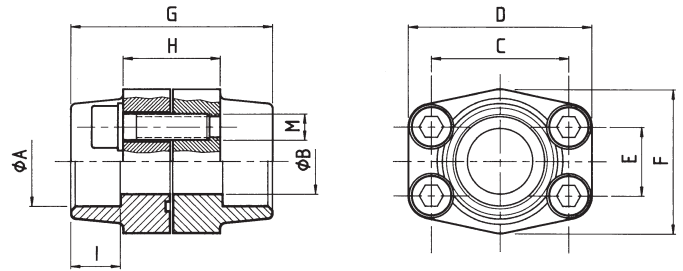

Bestellbezeichnung: ordering code:	S355J2^{*1}	1.4404^{*1} 316L
• Flansch mit metrischem Schraubensatz und O-Ring flange including metric bolts and o-ring	DFS-...SM	DFX-...SMX
• Flansch mit UNC-Schraubensatz und O-Ring flange with UNC bolts and o-ring	DFS-...SU	DFX-...SUX

maximaler Betriebsdruck maximum recommended working pressure	S.A.E. Baugröße nominal flange size	Typ type	Abmessungen dimensions										Schrauben bolts		Gewicht ohne Schrauben weight without bolts	
			A	B	C	D	E	F	G	H	I	M	kg			
kg/cm ²	inch															
Schraube Festigkeitskl. 10.9	Hochdruckreihe / High pressure											metr.	unc.			
420	1/2"	DFS 401S-012	21,6	13	40,5	54	18,2	46	72	32	19	M 8x30	5/16 x 1 1/4	0,52		
420	1/2"	DFS 401S-038	17,5	13	40,5	54	18,2	46	72	32	19	M 8x30	5/16 x 1 1/4	0,58		
420	1/2"	DFS 401S-A20	20,3	13	40,5	54	18,2	46	72	32	19	M 8x30	5/16 x 1 1/4	0,58		
420	3/4"	DFS 402 S	27,2	19	50,8	71	23,8	55	70	42	22	M 10x45	3/8 x 1 1/2	1,00		
420	3/4"	DFS 402 S-A25	25,3	19	50,8	71	23,8	55	70	42	22	M 10x45	3/8 x 1 1/2	1,00		
420	1"	DFS 403 S	34,0	25	57,2	81	27,8	65	84	50	22	M 12x50	7/16 x 1 3/4	1,52		
420	1"	DFS 403 S-A30	30,3	25	57,2	81	27,8	65	84	50	22	M 12x50	7/16 x 1 3/4	1,52		
420	1 1/4"	DFS 404 S	42,8	32	66,6	95	31,8	78	90	54	25	M 14x55	–	2,40		
420	1 1/4"	DFS 404 S-M12	42,8	32	66,6	95	31,8	78	90	54	25	M 12x45	1/2 x 1 3/4	2,40		
420	1 1/4"	DFS 404 S-A38	38,3	32	66,6	95	31,8	78	90	54	25	M 14x55	1/2 x 1 3/4	2,40		
420	1 1/2"	DFS 405 S	48,6	38	79,3	112	36,5	94	100	60	28	M 16x60	5/8 x 2	3,30		
420	1 1/2"	DFS 405 S-A50	50,5	38	79,3	112	36,5	94	100	60	28	M 16x60	5/8 x 2	3,30		
420	2"	DFS 406 S	61,0	51	96,8	134	44,5	114	130	74	24	M 20x75	3/4 x 2 1/2	4,90		
420	2 1/2"	DFS 407 S	76,6	63	123,8	180	58,8	152	160	90	32	M 24x90	–	–		
420	3"	DFS 408 S	90,5	73	152,4	208	71,6	178	180	110	33	M 30x110	–	–		

*1 oder vergleichbare Güte / or comparable material

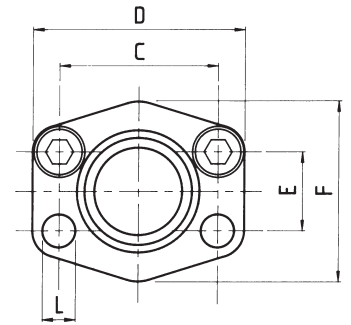
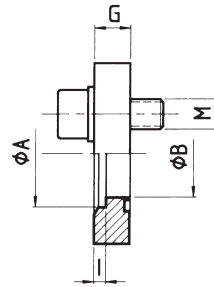

Bestellbezeichnung: ordering code:	S355J2^{*1}	1.4404^{*1} 316L
• nur Flansch flange only	AFC-...S	AFC-X-...S
• incl. metrischem Schraubensatz und O-Ring including metric bolts and o-ring	AFC-...SM	AFC-X-...SMX

maximaler Betriebsdruck maximum recommended working pressure	S.A.E. Baugröße nominal flange size	Typ type	Abmessungen dimensions											Schrauben bolts		Gewicht weight	
			Rohr/tube	A	B	C	D	E	F	G	I	L	M	kg			
kg/cm ²	inch																
Schraube Festigkeitskl.		Standarddruckreihe / Standard pressure													<i>metr.</i>	<i>unc.</i>	
10.9																	
40	1/2"	AFC 080 S	22x2	22,5	15	38,1	56	17,5	46	10	3	9,0	M 8x25	–	0,12		
40	3/4"	AFC 100 S	28x2	28,5	20	47,6	65	22,3	50	12	4	11,0	M 10x30	–	0,20		
40	1"	AFC 102 S	35x2	35,5	29	52,4	70	26,2	55	12	4	11,0	M 10x30	–	0,25		
40	1 1/4"	AFC 104 S	42x2	42,5	34	58,7	79	30,2	68	12	4	11,5	M 10x30	–	0,31		
40	1 1/2"	AFC 106 S	48,3x3,25	49,0	42	69,9	93	35,7	78	15	4	13,5	M 12x35	–	0,50		
40	2"	AFC 108 S	60,3x3,65	61,0	53	77,8	102	42,9	90	15	4	13,5	M 12x35	–	0,59		
40	2 1/2"	AFC 110 S	76,1x3,65	77,0	64	88,9	114	50,8	105	15	4	13,5	M 12x35	–	0,72		
40	3"	AFC 112 S	88,9x4,05	90,0	80	106,4	134	61,9	124	20	5	17,5	M 16x40	–	1,25		
35	3 1/2"	AFC 114 S	101,6x4,5	103,0	93	120,7	152	69,9	136	20	5	17,5	M 16x40	–	1,50		
35	4"	AFC 116 S	114,3x4,5	116,0	105	130,2	162	77,8	146	25	6	17,5	M 16x50	–	2,15		
35	5"	AFC 118 S	139,7x4,85	141,0	126	152,4	190	92,1	170	28	8	17,5	M 16x55	–	3,00		

*1 oder vergleichbare Güte / or comparable material

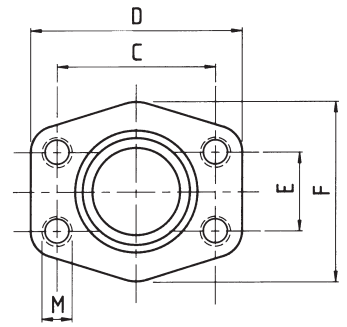
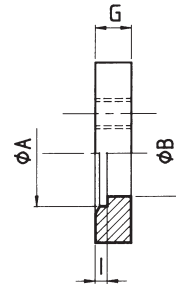

Bestellbezeichnung: ordering code:	S355J2^{*1}	1.4404^{*1} 316L
• nur Flansch flange only	GFC-...S	GFC-X-...S

maximaler Betriebsdruck maximum recommended working pressure	S.A.E. Baugröße nominal flange size	Typ type	Abmessungen dimensions										Gewinde thread	Gewicht weight	
			Rohr/tube	A	B	C	D	E	F	G	I	M			kg
kg/cm ²	inch														
Schraube Festigkeitskl. 10.9		Standarddruckreihe / Standard pressure													
40	1/2"	GFC 080 S	22x2	22,5	15	38,1	56	17,5	46	10	3	M 8	0,12		
40	3/4"	GFC 100 S	28x2	28,5	20	47,6	65	22,3	50	12	4	M 10	0,20		
40	1"	GFC 102 S	35x2	35,5	29	52,4	70	26,2	55	12	4	M 10	0,25		
40	1 1/4"	GFC 104 S	42x2	42,5	34	58,7	79	30,2	68	12	4	M 10	0,31		
40	1 1/2"	GFC 106 S	48,3x3,25	49,0	42	69,9	93	35,7	78	15	4	M 12	0,50		
40	2"	GFC 108 S	60,3x3,65	61,0	53	77,8	102	42,9	90	15	4	M 12	0,59		
40	2 1/2"	GFC 110 S	76,1x3,65	77,0	64	88,9	114	50,8	105	15	4	M 12	0,72		
40	3"	GFC 112 S	88,9x4,05	90,0	80	106,4	134	61,9	124	20	5	M 16	1,25		
35	3 1/2"	GFC 114 S	101,6x4,5	103,0	93	120,7	152	69,9	136	20	5	M 16	1,50		
35	4"	GFC 116 S	114,3x4,5	116,0	105	130,2	162	77,8	146	25	6	M 16	2,15		
35	5"	GFC 118 S	139,7x4,85	141,0	126	152,4	190	92,1	170	28	8	M 16	3,00		

*1 oder vergleichbare Güte / or comparable material

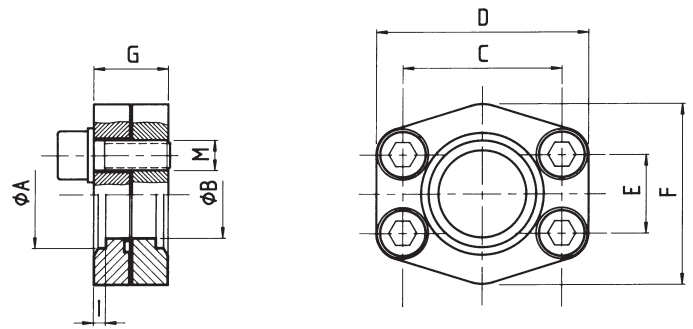

Bestellbezeichnung: ordering code:	S355J2 ^{*1}	1.4404 ^{*1} 316L
• Flansch incl. Schraubensatz und O-Ring flange including bolts and o-ring	DFC-...SM	DFC-X... SMX

maximaler Betriebsdruck maximum recommended working pressure	S.A.E. Baugröße nominal flange size	Typ type	Abmessungen dimensions										Schrauben bolts M	Gewicht weight kg
			Rohr/tube	A	B	C	D	E	F	G	I			
kg/cm ²	inch													
Schraube Festigkeitskl. 10.9		Standarddruckreihe / Standard pressure												
40	1/2"	DFC 080 S	22x2	22,5	15	38,1	56	17,5	46	20	3	M 8x25	0,24	
40	3/4"	DFC 100 S	28x2	28,5	20	47,6	65	22,3	50	24	4	M 10x30	0,40	
40	1"	DFC 102 S	35x2	35,5	29	52,4	70	26,2	55	24	4	M 10x30	0,50	
40	1 1/4"	DFC 104 S	42x2	42,5	34	58,7	79	30,2	68	24	4	M 10x30	0,62	
40	1 1/2"	DFC 106 S	48,3x3,25	49,0	42	69,9	93	35,7	78	30	4	M 12x35	1,00	
40	2"	DFC 108 S	60,3x3,65	61,0	53	77,8	102	42,9	90	30	4	M 12x35	1,18	
40	2 1/2"	DFC 110 S	76,1x3,65	77,0	64	88,9	114	50,8	105	30	4	M 12x35	1,44	
40	3"	DFC 112 S	88,9x4,05	90,0	80	106,4	134	61,9	124	40	5	M 16x40	2,50	
35	3 1/2"	DFC 114 S	101,6x4,5	103,0	93	120,7	152	69,9	136	40	5	M 16x40	3,00	
35	4"	DFC 116 S	114,3x4,5	116,0	105	130,2	162	77,8	146	50	6	M 16x50	4,30	
35	5"	DFC 118 S	139,7x4,85	141,0	126	152,4	190	92,1	170	56	8	M 16x60	6,00	

*1 oder vergleichbare Güte / or comparable material

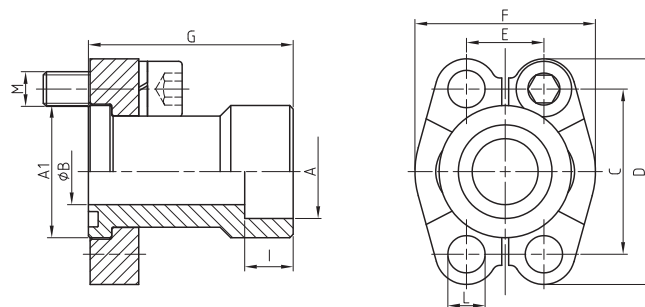
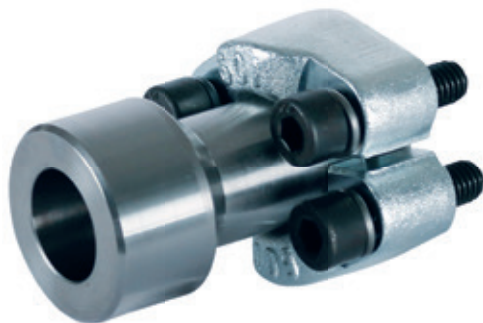

Bestellbezeichnung: ordering code:	S355J2^{*1}
<ul style="list-style-type: none"> nur Adapter adaptor only 	SWA-...
<ul style="list-style-type: none"> incl. Flanschhälften, metrischem Schraubensatz und O-Ring including split flanges, metric bolts and o-ring 	SWA-...M
<ul style="list-style-type: none"> incl. Flanschhälften, UNC-Schraubensatz und O-Ring including split flanges, UNC bolts and o-ring (nut and cutting ring) 	SWA-...U

maximaler Betriebsdruck maximum recommended working pressure	S.A.E. Baugröße nominal flange size	Typ type	Abmessungen dimensions											Schrauben bolts		Gewicht weight
			A	A1	B	C	D	E	F	G	I	L	M	kg		
kg/cm ²	inch													metr.	unc.	
Schraube Festigkeitskl. 10.9	Standarddruckreihe / Standard pressure											metr.	unc.			
350	1/2"	SWA-3001-20	20,30	30,2	13	38,1	54	17,5	46	50	15,0	8,50	M 8x25	5/16 x 1 1/4	-	
350	1/2"	SWA-3001-21,3	21,60	30,2	13	38,1	54	17,5	46	50	15,0	8,50	M 8x25	5/16 x 1 1/4	0,3	
350	3/4"	SWA-3002-25	25,30	38,1	19	47,6	65	22,3	52	60	14,8	10,50	M 10x30	3/8 x 1 1/4	0,6	
350	3/4"	SWA-3002-26,7	26,97	38,1	19	47,6	65	22,3	52	60	14,8	10,50	M 10x30	3/8 x 1 1/4	0,6	
320	1"	SWA-3003-30	30,30	44,5	24	52,4	70	26,2	59	60	15,6	10,50	M 10x30	3/8 x 1 1/4	0,9	
320	1"	SWA-3003-33,4	33,73	44,5	24	52,4	70	26,2	59	60	15,6	10,50	M 10x30	3/8 x 1 1/4	0,9	
280	1 1/4"	SWA-3004-38	38,30	50,8	32	58,7	79	30,2	73	66	16,7	*2	*3	7/16 x 1 1/2	1,2	
280	1 1/4"	SWA-3004-42,2	42,47	50,8	32	58,7	79	30,2	73	66	16,7	*2	*3	7/16 x 1 1/2	1,2	
210	1 1/2"	SWA-3005-48,3	48,82	60,3	38	69,9	94	35,7	83	73	19,2	13,30	M 12x35	1/2 x 1 1/2	1,5	
210	1 1/2"	SWA-3005-50	50,30	60,3	38	69,9	94	35,7	83	73	19,2	13,30	M 12x35	1/2 x 1 1/2	1,5	
210	2"	SWA-3006-60,3	61,11	71,4	51	77,8	102	42,9	97	76	22,2	13,30	M 12x35	1/2 x 1 1/2	-	
175	2 1/2"	SWA-3007-76,1	76,40	84,1	62	88,9	114	50,8	109	100	25,0	13,30	M 12x40	1/2 x 1 1/2	-	
160	3"	SWA-3008-88,9	90,40	101,6	73	106,4	135	61,9	131	125	28,0	17,00	M 16x50	5/8 x 2	-	
Schraube Festigkeitskl. 10.9	Hochdruckreihe / High pressure											metr.	unc.			
420	1/2"	SWA-6001-20	20,30	31,8	12	40,5	56	18,2	48	65	14,0	8,50	M 8x30	5/16 x 1 1/4	0,5	
420	1/2"	SWA-6001-21,3	21,60	31,8	12	40,5	56	18,2	48	65	14,0	8,50	M 8x30	5/16 x 1 1/4	0,5	
420	3/4"	SWA-6002-25	25,30	41,3	17	50,8	71	23,8	60	70	15,5	10,50	M 10x35	3/8 x 1 1/2	1,2	
420	3/4"	SWA-6002-26,7	26,97	41,3	17	50,8	71	23,8	60	70	15,5	10,50	M 10x35	3/8 x 1 1/2	1,2	
420	1"	SWA-6003-30	30,30	47,6	22	57,2	81	27,8	70	78	16,3	*4	M 12x45	7/16 x 1 3/4	1,5	
420	1"	SWA-6003-33,4	33,73	47,6	25	57,2	81	27,8	70	78	16,3	*4	M 12x45	7/16 x 1 3/4	1,5	
420	1 1/4"	SWA-6004-38	38,30	54,0	28	66,6	95	31,8	78	84	17,5	14,60	M 14x50	-	1,7	
420	1 1/4"	SWA-6004-38-M12	38,30	54,0	28	66,6	95	31,8	78	84	17,5	13,30	M 12x45	1/2 x 1 3/4	1,7	
420	1 1/4"	SWA-6004-42,2	42,47	54,0	28	66,6	95	31,8	78	84	17,5	14,60	M 14x50	-	1,7	
420	1 1/4"	SWA-6004-42,2-M12	42,47	54,0	28	66,6	95	31,8	78	84	17,5	13,30	M 12x45	1/2 x 1 3/4	1,7	
420	1 1/2"	SWA-6005-50	50,30	63,5	35	79,3	113	36,5	95	100	19,2	16,80	M 16x55	5/8 x 2	3,0	
420	1 1/2"	SWA-6005-48,3	48,82	63,5	35	79,3	113	36,5	95	100	19,2	16,80	M 16x55	5/8 x 2	3,0	
420	2"	SWA-6006-60,3	61,11	79,4	48	96,8	133	44,5	114	103	22,2	21,00	M 20x70	3/4 x 2 1/2	-	

*1 oder vergleichbare Güte / or comparable material

*2 wahlweise 10,50, 12,00 oder 12,75 / choice of 10.50, 12.00 or 12.75

*3 wahlweise M 10x30 oder M 12x35 / choice of M 10x30 or M 12x35

*4 wahlweise 12,0 oder 13,3 / choice of 12.0 or 13.3

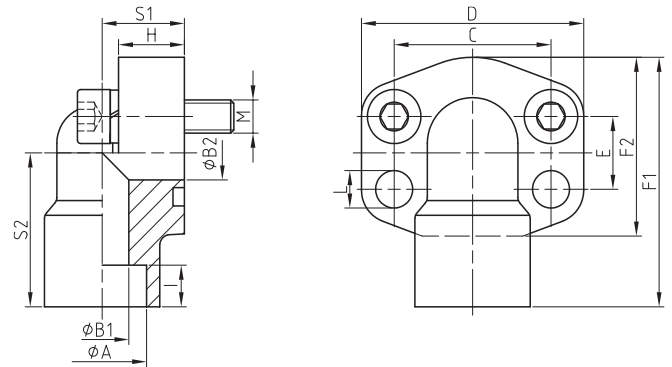

Bestellbezeichnung: ordering code:	S355J2*1	1.4404*1 316L
• nur Flansch flange only	AFS-.../90S	AFX-.../90S
• incl. metrischem Schraubensatz und O-Ring including metric bolts and o-ring	AFS-.../90SM	AFX-.../90SM
• incl. UNC-Schraubensatz und O-Ring including UNC bolts and o-ring	AFS-.../90SU	AFX-.../90SUX

maximaler Betriebsdruck maximum recommended working pressure	S.A.E. Baugröße nominal flange size	Typ type	Abmessungen dimensions													Schrauben bolts		Gewicht weight
			A	B1/B2	C	D	E	F1	F2	H	I	L	S1	S2	M	kg		
kg/cm ²	inch																	
Schraube Festigkeitskl. 10.9			Standarddruckreihe / Standard pressure													<i>metr.</i>	<i>unc.</i>	
350	1/2"	AFS 080/90 S	21,6	13	38,1	54	17,5	60	43	16	10	9,0	20	37	M 8x30	5/16 x 1 1/4	0,35	
350	1/2"	AFS 080/90 S-038	17,5	13	38,1	54	17,5	60	43	16	10	9,0	20	37	M 8x30	5/16 x 1 1/4	0,35	
350	3/4"	AFS 100/90 S	27,2	19	47,6	65	22,3	63	47	18	10	11,0	24	38	M 10x35	3/8 x 1 1/2	0,55	
320	1"	AFS 102/90 S	34,0	25	52,4	70	26,2	70	51	19	12	11,0	28	43	M 10x35	3/8 x 1 1/2	0,80	
280	1 1/4"	AFS 104/90 S	42,8	27/32	58,7	79	30,2	85	64	21	14	11,5	34	51	M 10x40	7/16 x 1 1/2	1,30	
210	1 1/2"	AFS 106/90 S	48,6	34/38	69,9	93	35,7	95	74	25	16	13,5	38	56	M 12x45	1/2 x 1 3/4	1,60	
210	2"	AFS 108/90 S	61,0	49/51	77,8	110	42,9	110	85	25	18	13,5	42	65	M 12x45	1/2 x 1 3/4	2,00	
175	2 1/2"	AFS 110/90 S	76,6	57/60	88,9	115	50,8	127	96	25	30	13,5	50	77	M 12x45	1/2 x 1 3/4	-	
Schraube Festigkeitskl. 10.9			HOCHDRUCKREIHE / High pressure													<i>metr.</i>	<i>unc.</i>	
420	1/2"	AFS 401/90 S-012	21,6	13	40,5	54	18,2	60	43	16	10	9,0	20	37	M 8x30	5/16 x 1 1/4	0,35	
420	1/2"	AFS 401/90 S-038	17,5	13	40,5	54	18,2	60	43	16	10	9,0	20	37	M 8x30	5/16 x 1 1/4	0,35	
420	3/4"	AFS 402/90 S	27,2	19	50,8	70	23,8	70	51	19	12	11,0	28	43	M 10x35	3/8 x 1 1/2	0,80	
420	3/4"	AFS 402/90 S 20	20,2	16/19	50,8	70	23,8	70	51	19	14	11,0	28	43	M 10x35	3/8 x 1 1/2	-	
420	3/4"	AFS 402/90 S 25	25,1	19	50,8	70	23,8	70	51	19	14	11,0	28	43	M 10x35	3/8 x 1 1/2	-	
420	3/4"	AFS 402/90 S 30	30,1	25/19	50,8	70	23,8	70	51	19	14	11,0	28	43	M 10x35	3/8 x 1 1/2	-	
420	1"	AFS 403/90 S	34,0	25	57,2	79	27,8	85	64	21	14	13,0	34	51	M 12x45	7/16 x 1 3/4	1,30	
420	1"	AFS 403/90 S 30	30,2	22/25	57,2	79	27,8	85	64	21	14	13,0	34	51	M 12x45	7/16 x 1 3/4	-	
420	1 1/4"	AFS 404/90 S	42,8	32	66,6	93	31,8	95	74	25	16	15,0	38	56	M 14x50	-	1,60	
420	1 1/4"	AFS 404/90 S 30	30,2	22/32	66,6	93	31,8	95	74	25	14	15,0	38	56	M 14x50	-	-	
420	1 1/4"	AFS 404/90 S 38	38,2	27/32	66,6	93	31,8	95	74	25	14	15,0	38	56	M 14x50	-	-	
420	1 1/2"	AFS 405/90 S	48,6	38	79,3	110	36,5	110	85	25	18	17,5	42	65	M 16x50	5/8 x 2	2,00	
420	2"	AFS 406/90 S	61,0	51	96,8	134	44,5	132	107	35	25	21,0	45	75	M 20x70	-	3,85	

*1 oder vergleichbare Güte / or comparable material

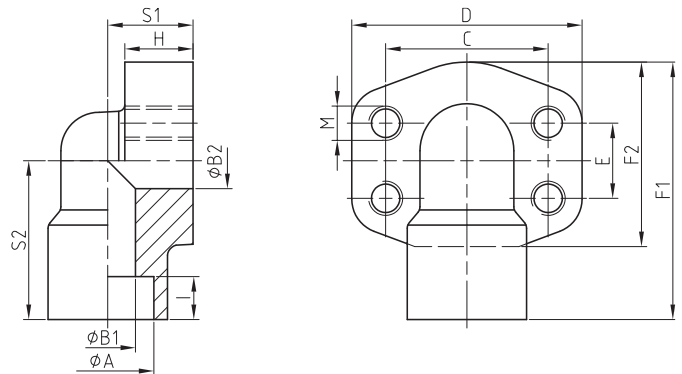

Bestellbezeichnung: ordering code:	S355J2 *1	1.4404 *1 316L
• nur Flansch flange only	GFS-.../90S	GFX-.../90S

maximaler Betriebsdruck maximum recommended working pressure	S.A.E. Baugröße nominal flange size	Typ type	Abmessungen dimensions											Gewinde thread		Gewicht weight		
			A	B1/B2	C	D	E	F1	F2	H	I	S1	S2	M	kg			
kg/cm ²	inch																	
Schraube Festigkeitskl. 10.9		Standarddruckreihe / Standard pressure													metr.	unc.		
350	1/2"	GFS 080/90 S	21,6	13	38,1	54	17,5	60	48	16,0	10	20	37	M 8	5/16	0,35		
350	1/2"	GFS 080/90 S-038	17,5	13	38,1	54	17,5	60	48	16,0	10	20	37	M 8	5/16	0,35		
350	3/4"	GFS 100/90 S	27,2	19	47,6	65	22,3	63	50	18,0	10	24	38	M 10	3/8	0,55		
320	1"	GFS 102/90 S	34,0	25	52,4	70	26,2	70	60	19,0	12	28	43	M 10	3/8	0,80		
280	1 1/4"	GFS 104/90 S	42,8	27/32	58,7	79	30,2	85	68	21,0	14	34	51	M 10	7/16	1,30		
210	1 1/2"	GFS 106/90 S	48,6	34/38	69,9	93	35,7	95	78	25,0	16	38	56	M 12	1/2	1,60		
210	2"	GFS 108/90 S	61,0	49/51	77,8	110	42,9	110	90	25,0	18	42	65	M 12	1/2	2,00		
Schraube Festigkeitskl. 10.9		Hochdruckreihe / High pressure													metr.	unc.		
420	1/2"	GFS 401/90 S-012	21,6	13	40,5	54	18,2	60	48	16,0	10	20	37	M 8	5/16	0,35		
420	1/2"	GFS 401/90 S-038	17,5	13	40,5	54	18,2	60	48	16,0	10	20	37	M 8	5/16	0,35		
420	3/4"	GFS 402/90 S	27,2	19	50,8	70	23,8	70	60	19,0	12	28	43	M 10	3/8	0,80		
420	3/4"	GFS 402/90 S-25	25,1	19	50,8	70	23,8	70	51	19,0	14	28	43	M 10	3/8	–		
420	1"	GFS 403/90 S	34,0	25	57,2	79	27,8	85	70	21,0	14	34	51	M 12	7/16	1,30		
420	1"	GFS 403/90 S-30	30,2	22/25	57,2	79	27,8	85	74	21,0	14	34	51	M 12	7/16	–		
420	1 1/4"	GFS 404/90 S	42,8	32	66,6	93	31,8	95	78	25,0	16	38	56	M 14	1/2	1,60		
420	1 1/4"	GFS 404/90 S-38	38,2	27/32	66,6	93	31,8	95	74	25	14	38	56	M 14	1/2	1,63		
420	1 1/2"	GFS 405/90 S	48,6	38	79,3	110	36,5	110	94	25,0	18	42	65	M 16	5/8	2,00		
420	2"	GFS 406/90 S	61,0	51	96,8	134	44,5	150	106	35,0	18	45	92	M 20	–	8,20		

*1 oder vergleichbare Güte / or comparable material

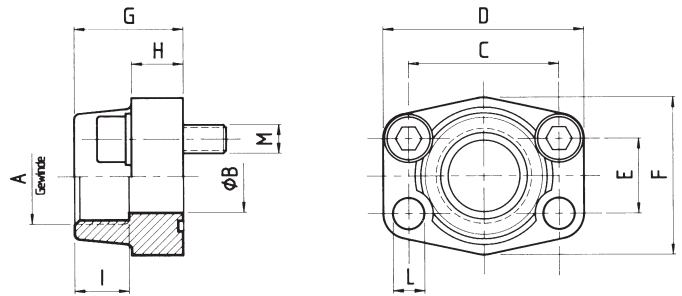

Bestellbezeichnung: ordering code:	S355J2^{*1}	1.4404^{*1} 316L
• nur Flansch flange only	AFS-...G	AFX-...G
• Flansch incl. metrischem Schraubensatz und O-Ring flange including metric bolts and o-ring	AFS-...GM	AFX-...GMX
• Flansch incl. UNC-Schraubensatz und O-Ring flange including UNC bolts and o-ring	AFS-...GU	AFX-...GUX

maximaler Betriebsdruck maximum recommended working pressure	S.A.E. Baugröße nominal flange size	Typ type	Abmessungen dimensions										Schrauben bolts		Gewicht weight
			A	B	C	D	E	F	G	H	I	L	M		
kg/cm ²	inch														
Schraube Festigkeitskl. 10.9	Standarddruckreihe / Standard pressure											metr.	unc.		
350	1/2"	AFS 080 G	G 1/2"	13	38,1	54	17,5	46	36	16	19	9,0	M 8x30	5/16 x 1 1/4	0,25
350	1/2"	AFS 080 G-038	G 3/8"	13	38,1	54	17,5	46	36	16	19	9,0	M 8x30	5/16 x 1 1/4	0,28
350	3/4"	AFS 100 G	G 3/4"	19	47,6	65	22,3	50	36	18	19	11,0	M 10x35	3/8 x 1 1/2	0,39
350	3/4"	AFS 100 G-012	G 1/2"	13	47,6	65	22,3	50	36	18	19	11,0	M 10x35	3/8 x 1 1/2	0,42
320	1"	AFS 102 G	G 1"	25	52,4	70	26,2	55	38	18	22	11,0	M 10x35	3/8 x 1 1/2	0,46
320	1"	AFS 102 G-034	G 3/4"	19	52,4	70	26,2	55	38	18	19	11,0	M 10x35	3/8 x 1 1/2	0,49
320	1"	AFS 102 G-012	G 1/2"	13	52,4	70	26,2	55	38	18	22	11,0	M 10x35	3/8 x 1 1/2	0,52
280	1 1/4"	AFS 104 G	G 1 1/4"	32	58,7	79	30,2	68	41	21	22	11,5	M 10x40	7/16 x 1 1/2	0,66
280	1 1/4"	AFS 104 G L=13	G 1 1/4"	32	58,7	79	30,2	68	41	21	22	13,0	M 12x40	-	0,66
280	1 1/4"	AFS 104 G-100	G 1"	25	58,7	81	30,2	65	42	25	22	11,5	M 10x40	7/16 x 1 3/4	0,75
280	1 1/4"	AFS 104 G-100 L=13	G 1"	25	58,7	81	30,2	65	42	25	22	13,0	M 12x40	-	0,75
280	1 1/4"	AFS 104 G-034	G 3/4"	19	58,7	79	30,2	68	41	21	22	11,5	M 10x40	7/16 x 1 1/2	0,79
210	1 1/2"	AFS 106 G	G 1 1/2"	38	69,9	93	35,7	78	45	25	24	13,5	M 12x45	1/2 x 1 3/4	1,05
210	1 1/2"	AFS 106 G-114	G 1 1/4"	32	69,9	95	35,7	78	45	27	24	13,5	M 12x45	1/2 x 1 3/4	1,10
210	1 1/2"	AFS 106 G-100	G 1"	25	69,9	93	35,7	78	45	25	24	13,5	M 12x45	1/2 x 1 3/4	1,16
210	1 1/2"	AFS 106 G-034	G 3/4"	19	69,9	93	35,7	78	45	25	24	13,5	M 12x45	1/2 x 1 3/4	1,23
210	2"	AFS 108 G	G 2"	51	77,8	102	42,9	90	45	25	30	13,5	M 12x45	1/2 x 1 3/4	1,19
210	2"	AFS 108 G-112	G 1 1/2"	38	77,8	102	42,9	90	45	25	26	13,5	M 12x45	1/2 x 1 3/4	1,25
210	2"	AFS 108 G-114	G 1 1/4"	32	77,8	102	42,9	90	45	25	24	13,5	M 12x45	1/2 x 1 3/4	1,40
210	2"	AFS 108 G-100	G 1"	25	77,8	102	42,9	90	45	25	22	13,5	M 12x45	1/2 x 1 3/4	1,44
175	2 1/2"	AFS 110 G	G 2 1/2"	63	88,9	114	50,8	105	50	25	30	13,5	M 12x45	1/2 x 1 3/4	1,40
175	2 1/2"	AFS 110 G-200	G 2"	51	88,9	114	50,8	105	50	25	30	13,5	M 12x45	1/2 x 1 3/4	1,45
160	3"	AFS 112 G	G 3"	73	106,4	134	61,9	124	50	27	34	17,5	M 16x50	5/8 x 2	2,15
160	3"	AFS 112 G-112	G 1 1/2"	38	106,4	134	61,9	124	50	27	25	17,5	M 16x50	5/8 x 2	3,7
160	3"	AFS 112 G-212	G 2 1/2"	63	106,4	134	61,9	124	50	27	30	17,5	M 16x50	5/8 x 2	2,25
35	3 1/2"	AFS 114 G	G 3 1/2"	89	120,7	152	69,9	136	48	27	34	17,5	M 16x50	5/8 x 2	2,40
35	3 1/2"	AFS 114 G-300	G 3"	73	120,7	152	69,9	136	48	27	34	17,5	M 16x50	5/8 x 2	2,50
35	4"	AFS 116 G	G 4"	99	130,2	162	77,8	146	48	27	34	17,5	M 16x50	5/8 x 2	2,85
35	4"	AFS 116 G-312	G 3 1/2"	89	130,2	162	77,8	146	48	27	34	17,5	M 16x50	5/8 x 2	3,00
35	5"	AFS 118 G	G 5"	120	152,4	184	92,1	180	50	28	30	17,5	M 16x55	5/8 x 2	5,80

*1 oder vergleichbare Güte / or comparable material

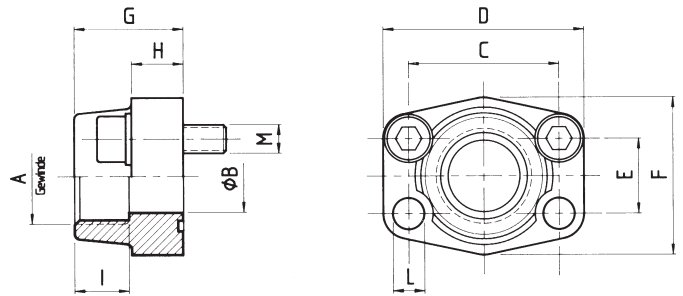

Bestellbezeichnung: ordering code:	S355J2^{*1}	1.4404^{*1} 316L
• nur Flansch flange only	AFS-...G	AFX-...G
• Flansch incl. metrischem Schraubensatz und O-Ring flange including metric bolts and o-ring	AFS-...GM	AFX-...GMX
• Flansch incl. UNC-Schraubensatz und O-Ring flange including UNC bolts and o-ring	AFS-...GU	AFX-...GUX

maximaler Betriebsdruck maximum recommended working pressure	S.A.E. Baugröße nominal flange size	Typ type	Abmessungen dimensions										Schrauben bolts		Gewicht weight	
			A	B	C	D	E	F	G	H	I	L	M			kg
kg/cm ²	inch															
Schraube Festigkeitskl. 10.9	Hochdruckreihe / High pressure															
420	1/2"	AFS 401G-012	G 1/2"	13	40,5	54	18,2	46	36	16	19	9	M 8x30	5/16 x 1 1/4	0,26	
420	1/2"	AFS 401G-038	G 3/8"	13	40,5	54	18,2	46	36	16	19	9	M 8x30	5/16 x 1 1/4	0,29	
420	3/4"	AFS 402 G	G 3/4"	19	50,8	71	23,8	55	35	21	22	11	M 10x35	3/8 x 1 1/2	0,50	
420	3/4"	AFS 402 G-012	G 1/2"	13	50,8	71	23,8	55	35	21	22	11	M 10x35	3/8 x 1 1/2	0,55	
420	1"	AFS 403 G	G 1"	25	57,2	81	27,8	65	42	25	24	13	M 12x45	7/16 x 1 3/4	0,76	
420	1"	AFS 403 G-034	G 3/4"	19	57,2	81	27,8	65	42	25	24	13	M 12x45	7/16 x 1 3/4	0,80	
420	1 1/4"	AFS 404 G-114	G 1 1/4"	32	66,6	95	31,8	78	45	27	25	15	M 14x50	–	1,20	
420	1 1/4"	AFS 404 G-114L=13	G 1 1/4"	32	66,6	95	31,8	78	45	27	25	13,5	M 12x45	1/2 x 1 3/4	1,17	
420	1 1/4"	AFS 404 G-100	G 1"	25	66,6	95	31,8	78	45	27	25	15	M 14x50	–	1,30	
420	1 1/4"	AFS 404 G-100L=13	G 1"	25	66,6	95	31,8	78	45	27	25	13,5	M 12x45	1/2 x 1 3/4	1,22	
420	1 1/2"	AFS 405 G	G 1 1/2"	38	79,3	112	36,5	94	50	30	28	17	M 16x50	5/8 x 2	1,65	
420	1 1/2"	AFS 405 G-114	G 1 1/4"	32	79,3	112	36,5	94	50	30	28	17	M 16x50	5/8 x 2	1,75	
420	2"	AFS 406 G	G 2"	51	96,8	134	44,5	114	65	37	30	21	M 20x70	3/4 x 2 1/2	2,45	
420	2"	AFS 406 G-112	G 1 1/2"	38	96,8	134	44,5	114	65	37	30	21	M 20x70	3/4 x 2 1/2	2,55	
420	2 1/2"	AFS 407 G	G 2 1/2"	63	123,8	180	58,8	152	80	45	32	26	M 24x80	–	6,75	
420	3"	AFS 408 G	G 3"	73	152,4	208	71,6	178	90	55	40	33	M 30x90	–	–	

*1 oder vergleichbare Güte / or comparable material

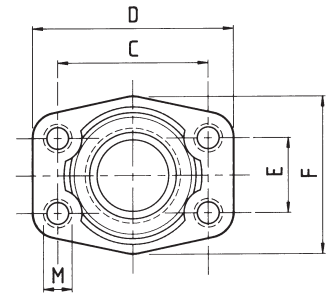
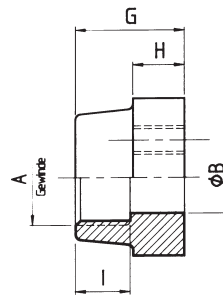

Bestellbezeichnung: ordering code:	S355J2^{*1}	1.4404^{*1} 316L
• Flansch mit metrischen Gewinden flange with metric threads	GFS-...GM	GFX-...GM
• Flansch mit UNC-Gewinden flange with UNC threads	GFS-...GU	GFX-...GU

maximaler Betriebsdruck maximum recommended working pressure	S.A.E. Baugröße nominal flange size	Typ type	Abmessungen dimensions									Gewinde thread		Gewicht weight
			A	B	C	D	E	F	G	H	I	M	kg	
kg/cm ²	inch													
Schraube Festigkeitskl. 10.9	Standarddruckreihe / Standard pressure											metr.	unc.	
350	1/2"	GFS 080 G	G 1/2"	13	38,1	54	17,5	46	36	16	19	M 8	5/16	0,25
350	1/2"	GFS 080 G-038	G 3/8"	13	38,1	54	17,5	46	36	16	19	M 8	5/16	0,28
350	3/4"	GFS 100 G	G 3/4"	19	47,6	65	22,3	50	36	18	19	M 10	3/8	0,39
350	3/4"	GFS 100 G-012	G 1/2"	13	47,6	65	22,3	50	36	18	19	M 10	3/8	0,42
320	1"	GFS 102 G	G 1"	25	52,4	70	26,2	55	38	18	22	M 10	3/8	0,46
320	1"	GFS 102 G-034	G 3/4"	19	52,4	70	26,2	55	35	21	19	M 10	3/8	0,49
280	1 1/4"	GFS 104 G	G 1 1/4"	32	58,7	79	30,2	68	41	21	22	M 10	7/16	0,66
280	1 1/4"	GFS 104 G-100	G 1"	25	58,7	81	30,2	65	42	25	22	M 10	7/16	0,75
210	1 1/2"	GFS 106 G	G 1 1/2"	38	69,9	93	35,7	78	45	25	24	M 12	1/2	1,05
210	1 1/2"	GFS 106 G-114	G 1 1/4"	32	69,9	95	35,7	78	45	27	24	M 12	1/2	1,10
210	2"	GFS 108 G	G 2"	51	77,8	102	42,9	90	45	25	30	M 12	1/2	1,19
210	2"	GFS 108 G-112	G 1 1/2"	38	77,8	102	42,9	90	45	25	26	M 12	1/2	1,25
175	2 1/2"	GFS 110 G	G 2 1/2"	63	88,9	114	50,8	105	50	25	30	M 12	1/2	1,40
175	2 1/2"	GFS 110 G-200	G 2"	51	88,9	114	50,8	105	50	25	30	M 12	1/2	1,45
160	3"	GFS 112 G	G 3"	73	106,4	134	61,9	124	50	27	34	M 16	5/8	2,15
160	3"	GFS 112 G-212	G 2 1/2"	63	106,4	134	61,9	124	50	27	30	M 16	5/8	2,25
35	3 1/2"	GFS 114 G	G 3 1/2"	89	120,7	152	69,9	136	48	27	34	M 16	5/8	2,40
35	3 1/2"	GFS 114 G-300	G 3"	73	120,7	152	69,9	136	48	27	34	M 16	5/8	2,50
35	4"	GFS 116 G	G 4"	99	130,2	162	77,8	146	48	27	34	M 16	5/8	2,85
35	4"	GFS 116 G-312	G 3 1/2"	89	130,2	162	77,8	146	48	27	34	M 16	5/8	3,00
35	5"	GFS 118 G	G 5"	120	152,4	184	92,1	180	50	28	30	M 16	5/8	5,80

*1 oder vergleichbare Güte / or comparable material

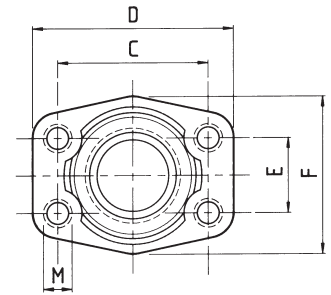
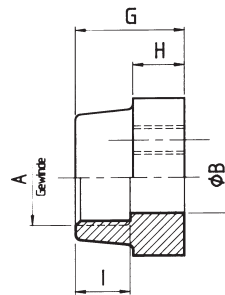

Bestellbezeichnung: ordering code:	S355J2^{*1}	1.4404^{*1} 316L
• Flansch mit metrischen Gewinden flange with metric threads	GFS-...GM	GFX-...GM
• Flansch mit UNC-Gewinden flange with UNC threads	GFS-...GU	GFX-...GU

maximaler Betriebsdruck maximum recommended working pressure	S.A.E. Baugröße nominal flange size	Typ type	Abmessungen dimensions										Gewinde thread		Gewicht weight
			A	B	C	D	E	F	G	H	I	M	kg		
kg/cm ²	inch												metr.	unc.	kg
Schraube Festigkeitskl. 10.9	Hochdruckreihe / High pressure														
420	1/2"	GFS 401G-012	G 1/2"	13	40,5	54	18,2	46	36	16	19	M 8	5/16	0,26	
420	1/2"	GFS 401G-038	G 3/8"	13	40,5	54	18,2	46	36	16	19	M 8	5/16	0,29	
420	3/4"	GFS 402 G	G 3/4"	19	50,8	71	23,8	55	35	21	22	M 10	3/8	0,50	
420	3/4"	GFS 402 G-012	G 1/2"	13	50,8	71	23,8	55	35	21	22	M 10	3/8	0,55	
420	1"	GFS 403 G	G 1"	25	57,2	81	27,8	65	42	25	24	M 12	7/16	0,76	
420	1"	GFS 403 G-034	G 3/4"	19	57,2	81	27,8	65	42	25	24	M 12	7/16	0,80	
420	1 1/4"	GFS 404 G-114	G 1 1/4"	32	66,6	95	31,8	78	45	27	25	M 14	1/2	1,20	
420	1 1/4"	GFS 404 G-114-M12	G 1 1/4"	32	66,6	95	31,8	78	45	27	25	M 12	1/2	1,20	
420	1 1/4"	GFS 404 G-100	G 1"	25	66,6	95	31,8	78	45	27	25	M 14	1/2	1,30	
420	1 1/4"	GFS 404 G-100-M12	G 1"	25	66,6	95	31,8	78	45	27	25	M 12	1/2	1,30	
420	1 1/2"	GFS 405 G	G 1 1/2"	38	79,3	112	36,5	94	50	30	28	M 16	5/8	1,65	
420	1 1/2"	GFS 405 G-114	G 1 1/4"	32	79,3	112	36,5	94	50	30	28	M 16	5/8	1,75	
420	2"	GFS 406 G	G 2"	51	96,8	134	44,5	114	65	37	30	M 20	3/4	2,45	
420	2"	GFS 406 G-112	G 1 1/2"	38	96,8	134	44,5	114	65	37	30	M 20	3/4	2,55	
420	2 1/2"	GFS 407 G	G 2 1/2"	63	123,8	180	58,8	152	80	45	32	M 24	-	6,98	
420	3"	GFS 408 G	G 3"	73	152,4	208	71,6	178	90	55	40	M 30	-	-	

*1 oder vergleichbare Güte / or comparable material

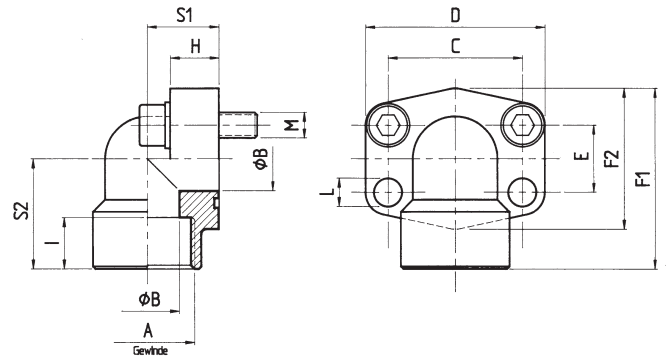

Bestellbezeichnung: ordering code:	S355J2 ^{*1}	1.4404 ^{*1} 316L
• nur Flansch flange only	AFS-.../90 G	AFX-.../90 G
• incl. metrischem Schraubensatz und O-Ring including metric bolts and o-ring	AFS-.../90 GM	AFX-.../90 GMX
• incl. UNC-Schraubensatz und O-Ring including UNC bolts and o-ring	AFS-.../90 GU	AFX-.../90 GUX

maximaler Betriebsdruck maximum recommended working pressure	S.A.E. Baugröße nominal flange size	Typ type	Abmessungen dimensions													Schrauben bolts		Gewicht weight	
			A	B	C	D	E	F1	F2	H	I	L	S1	S2	M	kg			
kg/cm ²	inch																metr.	unc.	kg
Schraube Festigkeitskl. 10.9	Standarddruckreihe / Standard pressure															metr.	unc.		
350	1/2"	AFS 080/90 G	G 1/2"	13	38,1	54	17,5	60	48	16	19	9,0	20	37	M 8x30	5/16 x 1 1/4	0,35		
350	1/2"	AFS 080/90 G-038	G 3/8"	13	38,1	54	17,5	60	48	16	19	9,0	20	37	M 8x30	5/16 x 1 1/4	0,35		
350	3/4"	AFS 100/90 G	G 3/4"	19	47,6	65	22,3	63	52	18	19	11,0	24	38	M 10x35	3/8 x 1 1/2	0,55		
320	1"	AFS 102/90 G	G 1"	22	52,4	70	26,2	71	51	19	20	11,0	28	43	M 10x35	3/8 x 1 1/2	0,80		
280	1 1/4"	AFS 104/90 G	G 1 1/4"	32	58,7	79	30,2	85	73	21	22	11,5	34	51	M 10x40	7/16 x 1 1/2	1,30		
210	1 1/2"	AFS 106/90 G	G 1 1/2"	38	69,9	93	35,7	95	83	25	25	13,5	38	56	M 12x45	1/2 x 1 3/4	1,60		
210	2"	AFS 108/90 G	G 2"	51	77,8	110	42,9	110	94	25	28	13,5	42	65	M 12x45	1/2 x 1 3/4	2,00		
175	2 1/2"	AFS 110/90 G	G 2 1/2"	60/57	88,9	115	50,8	127	96	25	30	13,5	50	77	M 12x45	1/2 x 1 3/4	-		

*1 oder vergleichbare Güte / or comparable material

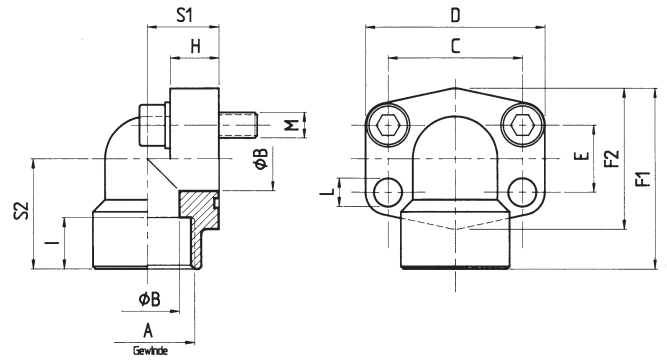

Bestellbezeichnung: ordering code:	S355J2^{*1}	1.4404^{*1} 316L
• nur Flansch flange only	AFS-.../90 G	AFX-.../90 G
• incl. metrischem Schraubensatz und O-Ring including metric bolts and o-ring	AFS-.../90 GM	AFX-.../90 GMX
• incl. UNC-Schraubensatz und O-Ring including UNC bolts and o-ring	AFS-.../90 GU	AFX-.../90 GUX

maximaler Betriebsdruck maximum recommended working pressure	S.A.E. Baugröße nominal flange size	Typ type	Abmessungen dimensions													Schrauben bolts		Gewicht weight	
			A	B	C	D	E	F1	F2	H	I	L	S1	S2	M	kg			
kg/cm ²	inch																metr.	unc.	kg
Schraube Festigkeitskl.			Hochdruckreihe / High pressure																
10.9																			
420	1/2"	AFS 401/90 G-012	G 1/2"	13	40,5	54	18,2	60	46	16	19	9,0	20	37	M 8x30	5/16 x 1 1/4	0,35		
420	1/2"	AFS 401/90 G-038	G 3/8"	13	40,5	54	18,2	60	46	16	19	9,0	20	37	M 8x30	5/16 x 1 1/4	0,35		
420	3/4"	AFS 402/90 G	G 3/4"	19	50,8	70	23,8	70	56	19	20	11,0	28	43	M 10x35	3/8 x 1 1/2	0,80		
420	1"	AFS 403/90 G	G 1"	25	57,2	79	27,8	85	72	21	22	13,0	34	51	M 12x45	7/16 x 1 3/4	1,30		
420	1 1/4"	AFS 404/90 G	G 1 1/4"	32	66,6	93	31,8	95	75	25	25	15,0	38	56	M 14x50	—	1,60		
420	1 1/2"	AFS 405/90 G	G 1 1/2"	38	79,3	110	36,5	110	94	25	28	17,0	42	65	M 16x50	5/8 x 2	2,00		
420	2"	AFS 406/90 G	G 2"	51	96,8	134	44,5	132	107	35	33	21,0	45	75	M 20x70	—	4,40		

*1 oder vergleichbare Güte / or comparable material

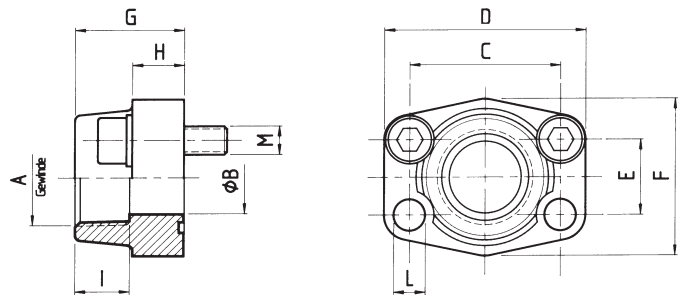

Bestellbezeichnung: ordering code:	S355J2^{*1}	1.4404^{*1} 316L
• nur Flansch flange only	AFS-...N	AFX-...N
• Flansch incl. metrischem Schraubensatz und O-Ring including metric bolts and o-ring	AFS-...NM	AFX-...NMX
• Flansch incl. UNC-Schraubensatz und O-Ring including unc bolts and o-ring	AFS-...NU	AFX-...NUX

maximaler Betriebsdruck maximum recommended working pressure	S.A.E. Baugröße nominal flange size	Typ type	Abmessungen dimensions										Schrauben bolts		Gewicht weight	
			A	B	C	D	E	F	G	H	I	L	M	kg		
kg/cm ²	inch															
Schraube Festigkeitskl. 10.9	Standarddruckreihe / Standard pressure													metr.	unc.	
350	1/2"	AFS 080 N	1/2" NPT	13	38,1	54	17,5	46	36	16	19	9,0	M 8x30	5/16 x 1 1/4	0,25	
350	1/2"	AFS 080 N-038	3/8" NPT	13	38,1	54	17,5	46	36	16	19	9,0	M 8x30	5/16 x 1 1/4	0,28	
350	3/4"	AFS 100 N	3/4" NPT	19	47,6	65	22,3	50	36	18	19	11,0	M 10x35	3/8 x 1 1/2	0,39	
350	3/4"	AFS 100 N-012	1/2" NPT	13	47,6	65	22,3	50	36	18	19	11,0	M 10x35	3/8 x 1 1/2	0,42	
320	1"	AFS 102 N	1" NPT	25	52,4	70	26,2	55	38	18	22	11,0	M 10x35	3/8 x 1 1/2	0,46	
320	1"	AFS 102 N-034	3/4" NPT	19	52,4	70	26,2	55	35	21	19	11,0	M 10x35	3/8 x 1 1/2	0,49	
280	1 1/4"	AFS 104 N	1 1/4" NPT	32	58,7	79	30,2	68	41	21	22	11,5	M 10x40	7/16 x 1 1/2	0,66	
280	1 1/4"	AFS 104 N-100	1" NPT	25	58,7	81	30,2	65	42	25	22	11,5	M 10x40	7/16 x 1 1/2	0,75	
210	1 1/2"	AFS 106 N	1 1/2" NPT	38	69,9	93	35,7	78	45	25	24	13,5	M 12x45	1/2 x 1 3/4	1,05	
210	1 1/2"	AFS 106 N-114	1 1/4" NPT	32	69,9	95	35,7	78	45	27	24	13,5	M 12x45	1/2 x 1 3/4	1,10	
210	2"	AFS 108 N	2" NPT	51	77,8	102	42,9	90	45	25	30	13,5	M 12x45	1/2 x 1 3/4	1,19	
210	2"	AFS 108 N-112	1 1/2" NPT	38	77,8	102	42,9	90	45	25	26	13,5	M 12x45	1/2 x 1 3/4	1,25	
175	2 1/2"	AFS 110 N	2 1/2" NPT	63	88,9	114	50,8	105	50	25	30	13,5	M 12x45	1/2 x 1 3/4	1,40	
160	3"	AFS 112 N	3" NPT	73	106,4	134	61,9	124	50	27	34	17,5	M 16x50	5/8 x 2	2,15	
35	3 1/2"	AFS 114 N	3 1/2" NPT	89	120,7	152	69,9	136	48	27	34	17,5	M 16x50	5/8 x 2	2,40	
35	4"	AFS 116 N	4" NPT	99	130,2	162	77,8	146	48	27	34	17,5	M 16x50	5/8 x 2	2,85	

*1 oder vergleichbare Güte / or comparable material

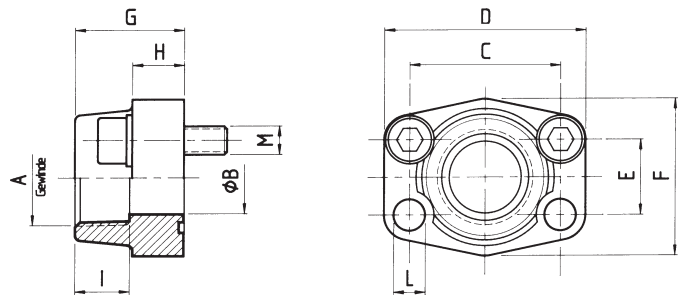

Bestellbezeichnung: ordering code:	S355J2^{*1}	1.4404^{*1} 316L
• nur Flansch flange only	AFS-...N	AFX-...N
• Flansch incl. metrischem Schraubensatz und O-Ring including metric bolts and o-ring	AFS-...NM	AFX-...NMX
• Flansch incl. UNC-Schraubensatz und O-Ring including unc bolts and o-ring	AFS-...NU	AFX-...NUX

maximaler Betriebsdruck maximum recommended working pressure	S.A.E. Baugröße nominal flange size	Typ type	Abmessungen dimensions										Schrauben bolts		Gewicht weight	
			A	B	C	D	E	F	G	H	I	L	M	kg		
kg/cm ²	inch															
Schraube Festigkeitskl. 10.9	Hochdruckreihe / High pressure												metr.	unc.		
420	1/2"	AFS 401 N-012	1/2" NPT	13	40,5	54	18,2	46	36	16	19	9,0	M 8x30	5/16 x 1 1/4	0,26	
420	1/2"	AFS 401 N-038	3/8" NPT	13	40,5	54	18,2	46	36	16	19	9,0	M 8x30	5/16 x 1 1/4	0,29	
420	3/4"	AFS 402 N	3/4" NPT	19	50,8	71	23,8	55	35	21	22	11,0	M 10x35	3/8 x 1 1/2	0,50	
420	3/4"	AFS 402 N-012	1/2" NPT	13	50,8	71	23,8	55	35	21	22	11,0	M 10x35	3/8 x 1 1/2	0,55	
420	1"	AFS 403 N	1" NPT	25	57,2	81	27,8	65	42	25	24	13,0	M 12x45	7/16 x 1 3/4	0,76	
420	1"	AFS 403 N-034	3/4" NPT	19	57,2	81	27,8	65	42	25	24	13,0	M 12x45	7/16 x 1 3/4	0,80	
420	1 1/4"	AFS 404 N	1 1/4" NPT	32	66,6	95	31,8	78	45	27	25	15,0	M 14x50	–	1,20	
420	1 1/4"	AFS 404 NL=13.5	1 1/4" NPT	32	66,6	95	31,8	78	45	27	25	13,5	M 12x45	1/2 x 1 3/4	1,20	
420	1 1/4"	AFS 404 N-100	1" NPT	25	66,6	95	31,8	78	45	27	25	15,0	M 14x50	–	1,30	
420	1 1/4"	AFS 404 N-100L=13.5	1" NPT	25	66,6	95	31,8	78	45	27	25	13,5	M 12x45	1/2 x 1 3/4	1,30	
420	1 1/2"	AFS 405 N	1 1/2" NPT	38	79,3	112	36,5	94	50	30	28	17,0	M 16x50	5/8 x 2	1,65	
420	1 1/2"	AFS 405 N-114	1 1/4" NPT	32	79,3	112	36,5	94	50	30	28	17,0	M 16x50	5/8 x 2	1,75	
420	2"	AFS 406 N	2" NPT	51	96,8	134	44,5	114	65	37	30	21,0	M 20x70	3/4 x 2 1/2	2,45	
420	2"	AFS 406 N-112	1 1/2" NPT	38	96,8	134	44,5	114	65	37	30	21,0	M 20x65	3/4 x 2 1/2	2,55	

*1 oder vergleichbare Güte / or comparable material

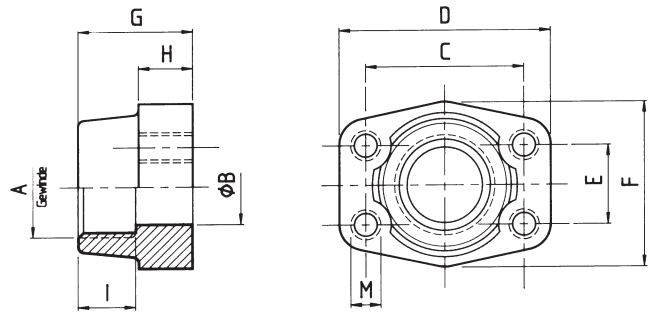

Bestellbezeichnung: ordering code:	S355J2^{*1}	1.4404^{*1} 316L
• Flansch mit metrischen Gewinden flange with metric threads	GFS-...NM	GFX-...NM
• Flansch mit UNC-Gewinden flange with UNC threads	GFS-...NU	GFX-...NU

maximaler Betriebsdruck maximum recommended working pressure	S.A.E. Baugröße nominal flange size	Typ type	Abmessungen dimensions										Gewinde thread		Gewicht weight
			A	B	C	D	E	F	G	H	I	M		kg	
kg/cm ²	inch												metr.	unc.	
Schraube Festigkeitskl.			Standarddruckreihe / Standard pressure												
10.9													metr.	unc.	
350	1/2"	GFS 080 N	1/2" NPT	13	38,1	54	17,5	46	36	16	19	M 8	5/16	0,25	
350	1/2"	GFS 080 N-038	3/8" NPT	13	38,1	54	17,5	46	36	16	19	M 8	5/16	0,28	
350	3/4"	GFS 100 N	3/4" NPT	19	47,6	65	22,3	50	36	18	19	M 10	3/8	0,39	
350	3/4"	GFS 100 N-012	1/2" NPT	13	47,6	65	22,3	50	36	18	19	M 10	3/8	0,42	
320	1"	GFS 102 N	1" NPT	25	52,4	70	26,2	55	38	18	22	M 10	3/8	0,46	
320	1"	GFS 102 N-034	3/4" NPT	19	52,4	70	26,2	55	35	21	19	M 10	3/8	0,49	
280	1 1/4"	GFS 104 N	1 1/4" NPT	32	58,7	79	30,2	68	41	21	22	M 10	7/16	0,66	
280	1 1/4"	GFS 104 N-100	1" NPT	25	58,7	81	30,2	65	42	25	22	M 10	7/16	0,75	
210	1 1/2"	GFS 106 N	1 1/2" NPT	38	69,9	93	35,7	78	45	25	24	M 12	1/2	1,05	
210	1 1/2"	GFS 106 N-114	1 1/4" NPT	32	69,9	95	35,7	78	45	27	24	M 12	1/2	1,10	
210	2"	GFS 108 N	2" NPT	51	77,8	102	42,9	90	45	25	30	M 12	1/2	1,19	
210	2"	GFS 108 N-112	1 1/2" NPT	38	77,8	102	42,9	90	45	25	26	M 12	1/2	1,25	
175	2 1/2"	GFS 110 N	2 1/2" NPT	63	88,9	114	50,8	105	50	25	30	M 12	1/2	1,40	
160	3"	GFS 112 N	3" NPT	73	106,4	134	61,9	124	50	27	34	M 16	5/8	2,15	
35	3 1/2"	GFS 114 N	3 1/2" NPT	89	120,7	152	69,9	136	48	27	34	M 16	5/8	2,40	
35	4"	GFS 116 N	4" NPT	99	130,2	162	77,8	146	48	27	34	M 16	5/8	2,85	
Schraube Festigkeitskl.			Hochdruckreihe / High pressure												
10.9													metr.	unc.	
420	1/2"	GFS 401 N-012	1/2" NPT	13	40,5	54	18,2	46	36	16	19	M 8	5/16	0,26	
420	1/2"	GFS 401 N-038	3/8" NPT	13	40,5	54	18,2	46	36	16	19	M 8	5/16	0,29	
420	3/4"	GFS 402 N	3/4" NPT	19	50,8	71	23,8	55	35	21	22	M 10	3/8	0,50	
420	3/4"	GFS 402 N-012	1/2" NPT	13	50,8	71	23,8	55	35	21	22	M 10	3/8	0,55	
420	1"	GFS 403 N	1" NPT	25	57,2	81	27,8	65	42	25	24	M 12	7/16	0,76	
420	1"	GFS 403 N-034	3/4" NPT	19	57,2	81	27,8	65	42	25	24	M 12	7/16	0,80	
420	1 1/4"	GFS 404 N	1 1/4" NPT	32	66,6	95	31,8	78	45	27	25	M 14	1/2	1,20	
420	1 1/4"	GFS 404 N-M12	1 1/4" NPT	32	66,6	95	31,8	78	45	27	25	M 12	1/2	1,20	
420	1 1/4"	GFS 404 N-100	1" NPT	25	66,6	95	31,8	78	45	27	25	M 14	1/2	1,30	
420	1 1/4"	GFS 404 N-100-M12	1" NPT	25	66,6	95	31,8	78	45	27	25	M 12	1/2	1,30	
420	1 1/2"	GFS 405 N	1 1/2" NPT	38	79,3	112	36,5	94	50	30	28	M 16	5/8	1,65	
420	1 1/2"	GFS 405 N-114	1 1/4" NPT	32	79,3	112	36,5	94	50	30	28	M 16	5/8	1,75	
420	2"	GFS 406 N	2" NPT	51	96,8	134	44,5	114	65	37	30	M 20	3/4	2,45	
420	2"	GFS 406 N-112	1 1/2" NPT	38	96,8	134	44,5	114	65	37	30	M 20	3/4	2,55	

*1 oder vergleichbare Güte / or comparable material

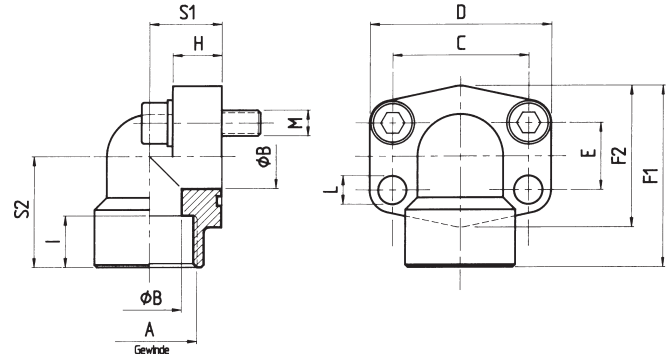

Bestellbezeichnung: ordering code:	S355J2^{*1}	1.4404^{*1} 316L
• nur Flansch flange only	AFS-.../90N	AFX-...90N
• incl. metrischem Schraubensatz und O-Ring including metric bolts and o-ring	AFS-.../90NM	AFX-...90NMX
• incl. UNC-Schraubensatz und O-Ring including UNC bolts and o-ring	AFS-.../90NU	AFX-...90NUX

maximaler Betriebsdruck maximum recommended working pressure	S.A.E. Baugröße nominal flange size	Typ type	Abmessungen dimensions													Schrauben bolts		Gewicht weight	
			A	B	C	D	E	F1	F2	H	I	L	S1	S2	M	kg			
kg/cm ²	inch															metr.	unc.	kg	
Schraube Festigkeitskl.			Standarddruckreihe / Standard pressure																
10,9																	metr.	unc.	
350	1/2"	AFS 080/90 N	1/2" NPT	13	38,1	54	17,5	60	48	16	19	9,0	20	37	M 8x30	5/16 x 1 1/4	0,35		
350	1/2"	AFS 080/90 N-038	3/8" NPT	13	38,1	54	17,5	60	48	16	19	9,0	20	37	M 8x30	5/16 x 1 1/4	0,35		
350	3/4"	AFS 100/90 N	3/4" NPT	19	47,6	65	22,3	63	52	18	19	11,0	24	38	M 10x35	3/8 x 1 1/2	0,55		
320	1"	AFS 102/90 N	1" NPT	25	52,4	70	26,2	70	60	19	20	11,0	28	43	M 10x35	3/8 x 1 1/2	0,80		
280	1 1/4"	AFS 104/90 N	1 1/4" NPT	32	58,7	79	30,2	85	73	21	22	11,5	34	51	M 10x40	7/16 x 1 1/2	1,30		
210	1 1/2"	AFS 106/90 N	1 1/2" NPT	38	69,9	93	35,7	95	83	25	25	13,5	38	56	M 12x45	1/2 x 1 3/4	1,60		
210	2"	AFS 108/90 N	2" NPT	51	77,8	110	42,9	110	94	25	28	13,5	42	65	M 12x45	1/2 x 1 3/4	2,00		
Schraube Festigkeitskl.			Hochdruckreihe / High pressure																
10,9																	metr.	unc.	
420	1/2"	AFS 401/90 N-012	1/2" NPT	13	40,5	54	18,2	60	46	16	19	9,0	20	37	M 8x30	5/16 x 1 1/4	0,35		
420	1/2"	AFS 401/90 N-038	3/8" NPT	13	40,5	54	18,2	60	46	16	19	9,0	20	37	M 8x30	5/16 x 1 1/4	0,35		
420	3/4"	AFS 402/90 N	3/4" NPT	19	50,8	70	23,8	70	55	19	20	11,0	28	43	M 10x35	3/8 x 1 1/2	0,80		
420	1"	AFS 403/90 N	1" NPT	25	57,2	79	27,8	85	72	21	22	13,0	34	51	M 12x45	7/16 x 1 3/4	1,30		
420	1 1/4"	AFS 404/90 N	1 1/4" NPT	32	66,6	93	31,8	95	75	25	25	15,0	38	56	M 14x50	–	1,60		
420	1 1/2"	AFS 405/90 N	1 1/2" NPT	38	79,3	110	36,5	110	94	25	28	17,0	42	65	M 16x50	5/8 x 2	2,00		

*1 oder vergleichbare Güte / or comparable material

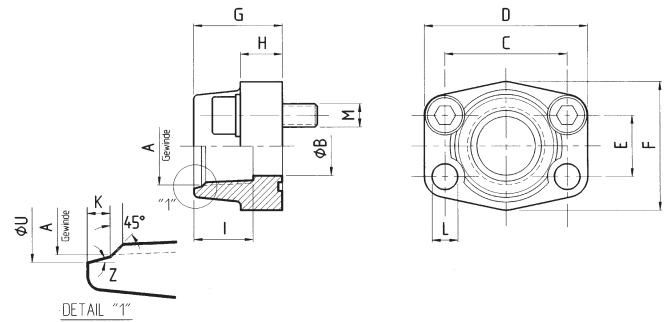

Bestellbezeichnung: ordering code:	S355J2 *1	1.4404 *1 316L
• nur Flansch flange only	AFS-...T	AFX-...T
• incl. metrischem Schraubensatz und O-Ring including metric bolts and o-ring	AFS-...TM	AFX-...TMX
• incl. UNC Schraubensatz und O-Ring including UNC bolts and o-ring	AFS-...TU	AFX-...TUX

maximaler Betriebsdruck maximum recommended working pressure	S.A.E. Baugröße nominal flange size	Typ type	Abmessungen dimensions													Schrauben bolts		Gewicht weight	
			A	B	C	D	E	F	G	H	I	L	U	K	Z	M	kg		
kg/cm ²	inch																		
			Standarddruckreihe / Standard pressure													metr.	unc.		
Schraube Festigkeitskl. 10.9																			
350	1/2"	AFS 080 T	3/4"-16UNF	13	38,1	54	17,5	46	36	16	17	9,0	20,6	2,5	15°	M 8x30	5/16 x 1 1/4	0,25	
350	3/4"	AFS 100 T	1 1/16"-12UN	19	47,6	65	22,3	50	36	18	23	11,0	29,2	3,3	15°	M 10x35	3/8 x 1 1/2	0,39	
320	1"	AFS 102 T	1 5/16"-12UN	25	52,4	70	26,2	55	38	18	23	11,0	35,5	3,3	15°	M 10x35	3/8 x 1 1/2	0,46	
280	1 1/4"	AFS 104 T	1 5/8"-12UN	32	58,7	79	30,2	68	41	21	23	11,5	43,5	3,3	15°	M 10x40	7/16 x 1 1/2	0,66	
210	1 1/2"	AFS 106 T	1 7/8"-12UN	38	69,9	93	35,7	78	45	25	23	13,5	49,8	3,3	15°	M 12x45	1/2 x 1 3/4	1,05	

*1 oder vergleichbare Güte / or comparable material

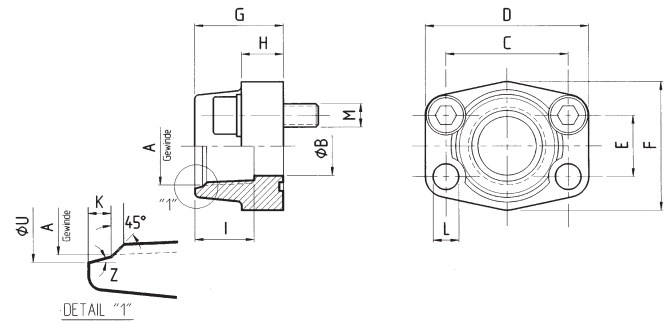

Bestellbezeichnung: ordering code:	S355J2^{*1}	1.4404^{*1} 316L
• nur Flansch flange only	AFS-...T	AFX-...T
• incl. metrischem Schraubensatz und O-Ring including metric bolts and o-ring	AFS-...TM	AFX-...TMX
• incl. UNC Schraubensatz und O-Ring including UNC bolts and o-ring	AFS-...TU	AFX-...TUX

maximaler Betriebsdruck maximum recommended working pressure	S.A.E. Baugröße nominal flange size	Typ type	Abmessungen dimensions													Schrauben bolts		Gewicht weight	
			A	B	C	D	E	F	G	H	I	L	U	K	Z	M			kg
kg/cm ²	inch																		
Schraube Festigkeitskl. 10.9	Hochdruckreihe / High pressure																metr.	unc.	
420	1/2"	AFS 401 T	3/4"-16UNF	13	40,5	54	18,2	46	36	16	17	9,0	20,6	2,5	15°	M 8x30	5/16 x 1 1/4	0,26	
420	3/4"	AFS 402 T	1 1/16"-12UN	19	50,8	71	23,8	55	35	21	23	11,0	29,3	3,3	15°	M 10x35	3/8 x 1 1/2	0,50	
420	1"	AFS 403 T	1 5/16"-12UN	25	57,2	81	27,8	65	42	25	23	13,0	35,5	3,3	15°	M 12x45	7/16 x 1 1/2	0,76	
420	1 1/4"	AFS 404 T	1 5/8"-12UN	32	66,6	95	31,8	78	45	27	23	15,0	43,5	3,3	15°	M 14x50	–	1,20	
420	1 1/4"	AFS 404 TL=13,5	1 5/8"-12UN	32	66,6	95	31,8	78	45	27	23	13,5	43,5	3,3	15°	M 12x45	1/2 x 1 3/4	1,16	
420	1 1/2"	AFS 405 T	1 7/8"-12UN	38	79,3	112	36,5	94	50	30	23	17,0	49,8	3,3	15°	M 16x50	5/8 x 2	1,65	

*1 oder vergleichbare Güte / or comparable material

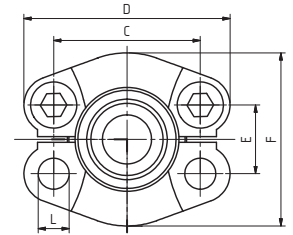
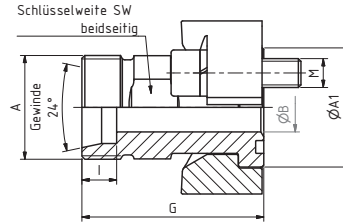

Bestellbezeichnung: ordering code:	S355J2^{*1} C22	1.4404^{*1} 316L
• nur Zwischenstück adaptor only	SFCE-...	SFCE-X-...
• incl. Flanschhälften, metrischem Schraubensatz und O-Ring (Mutter und Schneidring) including split flanges, metric bolts and o-ring (nut and cutting ring)	SFCE-...M(M)	SFCE-X-...MX(M)
• incl. Flanschhälften, UNC-Schraubensatz und O-Ring (Mutter und Schneidring) including split flanges, UNC bolts and o-ring (nut and cutting ring)	SFCE-...U(M)	SFCE-X-...UX(M)

DIN 3901
Bohrungsform W / Drill form W

maximaler Betriebsdruck maximum recommended working pressure	S.A.E. Baugröße nominal flange size	Typ type	Abmessungen dimensions											Schrauben bolts		Gewicht weight
			A	A1	B	C	D	E	F	G	I	SW	L	M	kg	
kg/cm ²	inch													metr.	unc.	
Schraube Festigkeitskl.			Standarddruckreihe / Standard pressure													
10.9																
315	1/2"	SFCE 3001/L15	M 22x1,5	30,2	12	38,1	54	17,5	46	48,2	7,0	24	8,50	M 8x25	5/16 x 1 1/4	0,29
350	1/2"	SFCE 3001/S16	M 24x1,5	30,2	12	38,1	54	17,5	46	50,2	8,5	24	8,50	M 8x25	5/16 x 1 1/4	0,32
315	3/4"	SFCE 3002/L18	M 26x1,5	38,1	15/17	47,6	65	22,3	52	53,2	7,5	30	10,50	M 10x30	3/8 x 1 1/2	0,55
160	3/4"	SFCE 3002/L22	M 30x2	38,1	19	47,6	65	22,3	52	53,2	7,5	30	10,50	M 10x30	3/8 x 1 1/2	0,56
160	3/4"	SFCE 3002/L28	M 36x2	38,1	19	47,6	65	22,3	52	53,2	7,5	30	10,50	M 10x30	3/8 x 1 1/2	0,75
350	3/4"	SFCE 3002/S20	M 30x2	38,1	16/17	47,6	65	22,3	52	57,2	10,5	30	10,50	M 10x30	3/8 x 1 1/2	0,63
350	3/4"	SFCE 3002/S25	M 36x2	38,1	17	47,6	65	22,3	52	57,2	12,0	30	10,50	M 10x30	3/8 x 1 1/2	0,76
160	1"	SFCE 3003/L28	M 36x2	44,5	24	52,4	70	26,2	59	54,2	7,5	36	10,50	M 10x30	3/8 x 1 1/2	0,69
320	1"	SFCE 3003/S25	M 36x2	44,5	20	52,4	70	26,2	59	58,2	12,0	36	10,50	M 10x30	3/8 x 1 1/2	0,78
320	1"	SFCE 3003/S30	M 42x2	44,5	24	52,4	70	26,2	59	63,2	13,5	36	10,50	M 10x30	3/8 x 1 1/2	0,91
160	1 1/4"	SFCE 3004/L28	M 36x2	50,8	24/27	58,7	79	30,2	73	58,2	7,5	36	*2	*3	7/16 x 1 1/2	1,05
160	1 1/4"	SFCE 3004/L35	M 45x2	50,8	30/32	58,7	79	30,2	73	58,2	10,5	41	*2	*3	7/16 x 1 1/2	1,10
280	1 1/4"	SFCE 3004/S25	M 36x2	50,8	20/27	58,7	79	30,2	73	60,2	12,0	41	*2	*3	7/16 x 1 1/2	1,17
280	1 1/4"	SFCE 3004/S30	M 42x2	50,8	25/28	58,7	79	30,2	73	62,2	13,5	41	*2	*3	7/16 x 1 1/2	1,19
280	1 1/4"	SFCE 3004/S38	M 52x2	50,8	28	58,7	79	30,2	73	66,2	16,0	46	*2	*3	7/16 x 1 1/2	1,39
160	1 1/2"	SFCE 3005/L42	M 52x2	60,3	36	69,9	94	35,7	83	64,2	11,0	46	13,30	M 12x35	1/2 x 1 1/2	1,34
210	1 1/2"	SFCE 3005/S38	M 52x2	60,3	32	69,9	94	35,7	83	70,2	16,0	46	13,30	M 12x35	1/2 x 1 1/2	1,50
160	2"	SFCE 3006/L42	M 52x2	71,4	36/51	77,8	102	42,9	97	80	11	46	13,3	M 12x35	1/2 x 1 1/2	1,51
210	2"	SFCE 3006/S38	M 52x2	71,4	32/51	77,8	102	42,9	97	80	16	46	13,3	M 12x35	1/2 x 1 1/2	1,51

Oberfläche: CR-6: auslaufend/Neu: CR-6 frei / surface: CR-6: phase-out/New: CR-6 free
*1 oder vergleichbare Güte / or comparable material

*2 wahlweise 10,50 oder 12,75 / choice of 10.50 or 12.75

*3 wahlweise M 10x30 oder M 12x35 / choice of M 10x30 or M 12x35

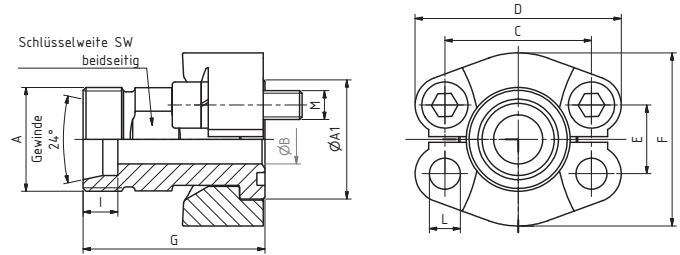

Bestellbezeichnung: ordering code:	S355J2^{*1} C22	1.4404^{*1} 316L
• nur Zwischenstück adaptor only	SFCE-...	SFCE-X-...
• incl. Flanschhälften, metrischem Schraubensatz und O-Ring (Mutter und Schneidring) including split flanges, metric bolts and o-ring (nut and cutting ring)	SFCE-...M(M)	SFCE-X-...MX(M)
• incl. Flanschhälften, UNC-Schraubensatz und O-Ring (Mutter und Schneidring) including split flanges, UNC bolts and o-ring (nut and cutting ring)	SFCE-...U(M)	SFCE-X-...UX(M)

DIN 3901
Bohrungsform W / Drill form W

maximaler Betriebsdruck maximum recommended working pressure	S.A.E. Baugröße nominal flange size	Typ type	Abmessungen dimensions											Schrauben bolts		Gewicht weight		
			A	A1	B	C	D	E	F	G	I	SW	L	M			kg	
kg/cm ²	inch																	
Schraube Festigkeitskl. 10.9	Hochdruckreihe / High pressure														metr.	unc.		
420	1/2"	SFCE 6001/S16	M 24x1,5	31,8	12	40,5	56	18,2	48	53,2	8,5	24	8,50	M 8x30	5/16 x 1 1/4	0,46		
420	3/4"	SFCE 6002/L22	M 30x2	41,3	19	50,8	71	23,8	60	61,0	7,5	30	10,50	M 10x35	3/8 x 1 1/2	0,76		
420	3/4"	SFCE 6002/S16	M 24x1,5	41,3	12/17	50,8	71	23,8	60	59,2	8,5	30	10,50	M 10x35	3/8 x 1 1/2	0,78		
420	3/4"	SFCE 6002/S20	M 30x2	41,3	16	50,8	71	23,8	60	61,2	10,5	30	10,50	M 10x35	3/8 x 1 1/2	0,84		
420	3/4"	SFCE 6002/S25	M 36x2	41,3	17	50,8	71	23,8	60	63,2	12,0	30	10,50	M 10x35	3/8 x 1 1/2	0,96		
420	3/4"	SFCE 6002/S30	M 42x2	41,3	24/18	50,8	71	23,8	60	64,0	13,5	36	10,50	M 10x35	3/8 x 1 1/2	1,20		
420	1"	SFCE 6003/S25	M 36x2	47,6	20	57,2	81	27,8	70	72,2	12,0	36	*2	M 12x45	7/16 x 1 3/4	1,42		
420	1"	SFCE 6003/S30	M 42x2	47,6	24	57,2	81	27,8	70	74,0	13,5	36	*2	M 12x45	7/16 x 1 3/4	1,52		
350	1"	SFCE 6003/S38	M 52x2	47,6	24	57,2	81	27,8	70	90,0	16,0	46	*2	M 12x45	7/16 x 1 3/4	1,42		
420	1 1/4"	SFCE 6004/S25	M 36x2	54,0	20/30	66,6	95	31,8	78	79,2	13,5	41	14,60	M 14x50	—	1,93		
420	1 1/4"	SFCE 6004/S25-M12	M 36x2	54,0	20/30	66,6	95	31,8	78	79,2	13,5	41	13,30	M 12x45	1/2 x 1 3/4	1,93		
420	1 1/4"	SFCE 6004/S30	M 42x2	54,0	25/30	66,6	95	31,8	78	79,2	13,5	41	14,60	M 14x50	—	1,93		
420	1 1/4"	SFCE 6004/S30-M12	M 42x2	54,0	25/30	66,6	95	31,8	78	79,2	13,5	41	13,30	M 12x45	1/2 x 1 3/4	1,93		
350	1 1/4"	SFCE 6004/S38	M 52x2	54,0	30	66,6	95	31,8	78	83,2	16,0	46	14,60	M 14x50	—	2,08		
350	1 1/4"	SFCE 6004/S38-M12	M 52x2	54,0	30	66,6	95	31,8	78	83,2	16,0	46	13,30	M 12x45	1/2 x 1 3/4	2,08		
350	1 1/2"	SFCE 6005/S38	M 52x2	63,5	30	79,3	113	36,5	95	89,2	16,0	46	16,80	M 16x55	5/8 x 2	3,03		
350	2"	SFCE 6006/S38	M 52x2	79,4	30/47	96,8	133	44,5	114	85,0	16,0	46	21,00	M 20x70	3/4 x 2 1/2	3,40		

Oberfläche: CR-6: auslaufend/Neu: CR-6 frei / surface: CR-6: phase-out/New: CR-6 free
*1 oder vergleichbare Güte / or comparable material

*2 wahlweise 10,75 oder 12,75 / choice of 10.75 or 12.75

*3 wahlweise M 10x30 oder M 12x35 / choice of M 10x30 or M 12x35

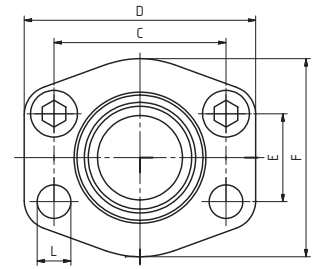
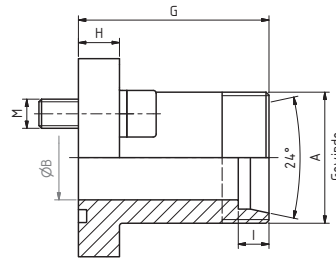

Bestellbezeichnung: ordering code:	S355J2^{*1}
• nur Flansch flange only	AFG-...
• incl. metrischem Schraubensatz und O-Ring including metric bolts and o-ring	AFG-...M
• incl. UNC-Schraubensatz und O-Ring including UNC bolts and o-ring	AFG-...U
• incl. Schraubensatz (metrisch oder UNC), O-Ring, Schneidring und Mutter including bolts (metr. or UNC), o-ring, cutting ring and nut	AFG-...MM (UM)

DIN 3901
Bohrungsform W / Drill form W

maximaler Betriebsdruck maximum recommended working pressure	S.A.E. Baugröße nominal flange size	Typ type	Abmessungen dimensions										Schrauben bolts		Gewicht weight		
			A	B	C	D	E	F	G	H	I	L	M	kg			
kg/cm ²	inch																
Schraube Festigkeitskl. 10.9	Standarddruckreihe / Standard pressure													metr.	unc.		
315	1/2"	AFG 080 M/L 15	M 22x1,5	12	38,1	54	17,5	46	52	13	7,0	9,0	M 8x25	5/16 x 1 1/4	0,25		
315	1/2"	AFG 080 M/S 16	M 24x1,5	12	38,1	54	17,5	46	52	13	8,5	9,0	M 8x25	5/16 x 1 1/4	0,25		
160	3/4"	AFG 100 M/L 22	M 30x2	19	47,6	65	22,3	50	60	14	7,5	11,5	M 10x30	3/8 x 1 1/4	0,35		
345	3/4"	AFG 100 M/S 20	M 30x2	16	47,6	65	22,3	50	60	14	10,5	11,5	M 10x30	3/8 x 1 1/4	0,36		
160	1"	AFG 102 M/L 22	M 30x2	19	52,4	70	26,2	55	63	16	7,5	11,5	M 10x30	3/8 x 1 1/4	0,44		
160	1"	AFG 102 M/L 28	M 36x2	24	52,4	70	26,2	55	63	16	7,5	11,5	M 10x30	3/8 x 1 1/4	0,50		
320	1"	AFG 102 M/S 20	M 30x2	16	52,4	70	26,2	55	63	16	10,5	11,5	M 10x30	3/8 x 1 1/4	0,46		
320	1"	AFG 102 M/S 25	M 36x2	20	52,4	70	26,2	55	63	16	12,0	11,5	M 10x30	3/8 x 1 1/4	0,52		
160	1 1/4"	AFG 104 M/L 28	M 36x2	24	58,7	79	30,2	68	65	14	7,5	11,5	M 10x30	7/16 x 1 1/2	0,68		
160	1 1/4"	AFG 104 M/L 35	M 45x2	29	58,7	79	30,2	68	65	14	10,5	11,5	M 10x30	7/16 x 1 1/2	0,72		
280	1 1/4"	AFG 104 M/S 30	M 42x2	25	58,7	79	30,2	68	65	14	13,5	11,5	M 10x30	7/16 x 1 1/2	0,70		
160	1 1/2"	AFG 106 M/L 42	M 52x2	36	69,9	94	35,7	78	70	16	11,0	13,5	M 12x35	1/2 x 1 1/2	1,00		
210	1 1/2"	AFG 106 M/S 38	M 52x2	32	69,9	94	35,7	78	70	16	16,0	13,5	M 12x35	1/2 x 1 1/2	1,02		
210	2"	AFG 108 M/L 42 - H 74	M 52x2	36	77,8	102	42,9	90	74	25	11,0	13,5	M 12x45	1/2 x 1 3/4	1,81		
210	2"	AFG 108 M/S 38 - H 74	M 52x2	32	77,8	102	42,9	90	74	25	16,0	13,5	M 12x45	1/2 x 1 3/4	1,92		

*1 oder vergleichbare Güte / or comparable material

*2 L=13,5 für UNC-Schrauben / L=13.5 with UNC-bolts

Hinweis: Der angegebene Nenndruck ist nach der SAE J 518 C durch den Flansch bzw. nach der Verschraubung nach DIN 3861 festgelegt. / **Please note:** The maximum working pressure is fixed by SAE J 518 C on flange side or by the thread side to DIN 3861.

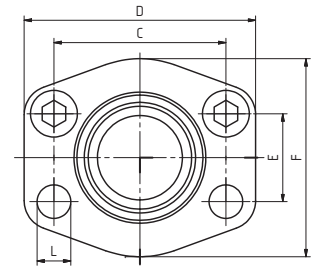
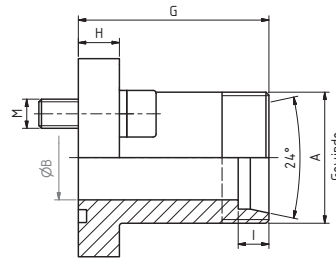

Bestellbezeichnung: ordering code:	S355J2^{*1}
• nur Flansch flange only	AFG-...
• incl. metrischem Schraubensatz und O-Ring including metric bolts and o-ring	AFG-...M
• incl. UNC-Schraubensatz und O-Ring including UNC bolts and o-ring	AFG-...U
• incl. Schraubensatz (metrisch oder UNC), O-Ring, Schneidring und Mutter including bolts (metr. or UNC), o-ring, cutting ring and nut	AFG-...MM (UM)

maximaler Betriebsdruck maximum recommended working pressure	S.A.E. Baugröße nominal flange size	Typ type	Abmessungen dimensions										Schrauben bolts		Gewicht weight		
			A	B	C	D	E	F	G	H	I	L	M	kg			
kg/cm ²	inch																
Schraube Festigkeitskl. 10.9	Hochdruckreihe / High pressure											metr.	unc.				
420	1/2"	AFG 401 M/S 16	M 24x1,5	12	40,5	56	18,2	48	60	16	8,5	9,0	M 8x30	5/16 x 1 1/4	0,30		
420	3/4"	AFG 402 M/S 16-50	M 24x1,5	12	50,8	71	23,8	50	52	19	8,5	11,5	M 10x35	3/8 x 1 1/2	-		
420	3/4"	AFG 402 M/S 20-50	M 30x2	16	50,8	71	23,8	50	52	19	10,5	11,5	M 10x35	3/8 x 1 1/2	-		
420	3/4"	AFG 402 M/S 25-50	M 36x2	18	50,8	71	23,8	50	52	19	12,0	11,5	M 10x35	3/8 x 1 1/2	-		
420	3/4"	AFG 402 M/S 25	M 36x2	19	50,8	71	23,8	60	73	19	12,0	11,5	M 10x35	3/8 x 1 1/2	0,68		
420	1"	AFG 403 M/S 20-60	M 30x2	16	57,2	81	27,8	70	60	24	10,5	13,0	M 12x45	7/16 x 1 3/4	-		
420	1"	AFG 403 M/S 25	M 36x2	19/26	57,2	81	27,8	70	82	24	12,0	13,0	M 12x45	7/16 x 1 3/4	1,17		
420	1"	AFG 403 M/S 30	M 42x2	25	57,2	81	27,8	70	82	24	13,5	13,0	M 12x45	7/16 x 1 3/4	1,00		
420	1 1/4"	AFG 404 M/S 30	M 42x2	25	66,6	95	31,8	78	92	27	13,5	15,0 ^{*2}	M 14x50	1/2 x 1 3/4	1,54		
420	1 1/4"	AFG 404 M/S 30-68	M 42x2	25	66,6	95	31,8	78	68	27	13,5	15,0 ^{*2}	M 14x50	1/2 x 1 3/4	-		
420	1 1/4"	AFG 404 M/S 38	M 52x2	29	66,6	95	31,8	78	92	27	16,0	15,0 ^{*2}	M 14x50	1/2 x 1 3/4	1,60		
420	1 1/4"	AFG 404 M/S 38-60	M 52x2	28	66,6	95	31,8	78	60	24	16,0	15,0 ^{*2}	M 14x50	1/2 x 1 3/4	-		
420	1 1/2"	AFG 405 M/S 38	M 52x2	32	79,3	113	36,5	95	96	30	16,0	17,5	M 16x55	5/8 x 2	2,20		
420	1 1/2"	AFG 405 M/S 38-72	M 52x2	32	79,3	113	36,5	95	72	30	16	17,5	M 16x55	5/8 x 2	2,05		

*1 oder vergleichbare Güte / or comparable material

*2 L=13,5 für UNC-Schrauben / L=13.5 with UNC-bolts

Hinweis: Der angegebene Nenndruck ist nach der SAE J 518 C durch den Flansch bzw. nach der Verschraubung nach DIN 3861 festgelegt. / **Please note:** The maximum working pressure is fixed by SAE J 518 C on flange side or by the thread side to DIN 3861.

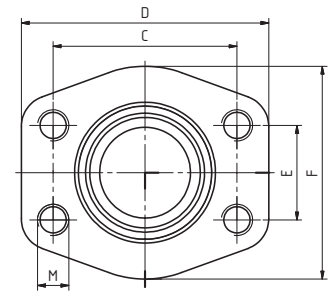
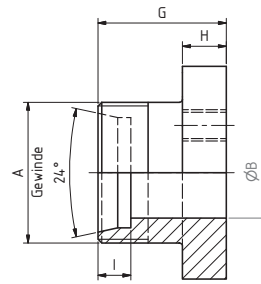

Bestellbezeichnung: ordering code:	S355J2^{*1}	1.4404^{*1} 316L
• Flansch mit metrischen Gewinden flange with metric threads	GFG-...L/S...	

maximaler Betriebsdruck maximum recommended working pressure	S.A.E. Baugröße nominal flange size	Typ type	Abmessungen dimensions									Gewinde thread		Gewicht weight
			A	B	C	D	E	F	G	H	I	M	kg	
kg/cm ²	inch													
Schraube Festigkeitskl.		Standarddruckreihe / Standard pressure										metr.	unc.	
10.9														
315	1/2"	GFG-080M/L15	M22x1,5	12,0	38,1	54,0	17,5	46,0	36,0	13,0	7,0	M8	5/16	0,23
350	1/2"	GFG-080M/S16	M24x1,5	12,0	38,1	54,0	17,5	46,0	36,0	13,0	8,5	M8	5/16	0,24
160	3/4"	GFG-100M/L22	M30x2	19,0	47,6	65,0	22,3	50,0	36,0	14,0	7,5	M10	3/8	0,33
345	3/4"	GFG-100M/S20	M30x2	16,0	47,6	65,0	22,3	50,0	36,0	14,0	10,5	M10	3/8	0,35
160	1"	GFG-102M/L22	M30x2	19,0	52,4	70,0	26,2	55,0	38,0	16,0	7,5	M10	3/8	0,43
160	1"	GFG-102M/L28	M36x2	24,0	52,4	70,0	26,2	55,0	38,0	16,0	7,5	M10	3/8	0,43
320	1"	GFG-102M/S20	M30x2	16/25	52,4	70,0	26,2	55,0	38,0	16,0	10,5	M10	3/8	0,44
320	1"	GFG-102M/S25	M36x2	20/25	52,4	70,0	26,2	55,0	38,0	16,0	12,0	M10	3/8	0,46
160	1 1/4"	GFG-104M/L28	M36x2	24,0	58,7	79,0	30,2	68,0	41,0	14,0	7,5	M10	7/16	0,53
160	1 1/4"	GFG-104M/L35	M45x2	29,0	58,7	79,0	30,2	68,0	41,0	14,0	10,5	M10	7/16	0,56
280	1 1/4"	GFG-104M/S30	M42x2	25,0	58,7	79,0	30,2	68,0	41,0	14,0	13,5	M10	7/16	0,58
160	1 1/2"	GFG-106M/L42	M52x2	36,0	69,9	93,0	35,7	78,0	45,0	16,0	11,0	M12	1/2	0,83
210	1 1/2"	GFG-106M/S38	M52x2	32/36	69,9	93,0	35,7	78,0	45,0	16,0	16,0	M12	1/2	0,89

*1 oder vergleichbare Güte / or comparable material

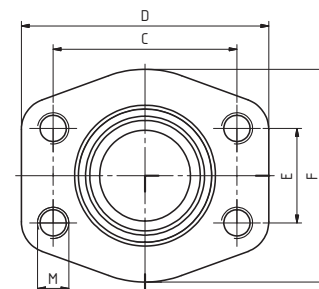
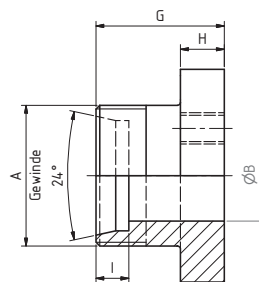

Bestellbezeichnung: ordering code:	S355J2^{*1}	1.4404^{*1} 316L
• Flansch mit metrischen Gewinden flange with metric threads	GFG-...L/S...	

maximaler Betriebsdruck maximum recommended working pressure	S.A.E. Baugröße nominal flange size	Typ type	Abmessungen dimensions									Gewinde thread		Gewicht weight	
			A	B	C	D	E	F	G	H	I	M	kg		
kg/cm ²	inch														
Schraube Festigkeitskl.	Hochdruckreihe / High pressure											metr.	unc.		
10.9															
420	1/2"	GFG-401M/S16	M24x1,5	12,0	40,5	54,0	18,2	46,0	36,0	16,0	8,5	M8	5/16	0,27	
420	3/4"	GFG-402M/S16	M24x1,5	12,0	50,8	70,0	23,8	55,0	38,0	19,0	8,5	M10	3/8	0,50	
420	3/4"	GFG-402M/S20	M30x2	16,0	50,8	70,0	23,8	55,0	38,0	19,0	10,5	M10	3/8	0,51	
420	3/4"	GFG-402M/S25	M36x2	19,0	50,8	70,0	23,8	55,0	40,0	19,0	12,0	M10	3/8	0,53	
420	1"	GFG-403M/S20	M30x2	16,0	57,2	81,0	27,8	65,0	42,0	24,0	10,5	M12	7/16	0,82	
420	1"	GFG-403M/S30	M42x2	25,0	57,2	81,0	27,8	65,0	42,0	23,0	13,5	M12	7/16	0,78	
420	1 1/4"	GFG-404M/S30	M42x2	25,0	66,6	95,0	31,8	78,0	60,0	24,0	13,5	M14	1/2	1,23	
420	1 1/4"	GFG-404M/S38	M52x2	29,0	66,6	95,0	31,8	78,0	60,0	24,0	16,0	M14	1/2	1,32	
420	1 1/2"	GFG-405M/S38	M52x2	32,0	79,3	112,0	36,5	94,0	55,0	30,0	16,0	M16	5/8	1,96	

*1 oder vergleichbare Güte / or comparable material

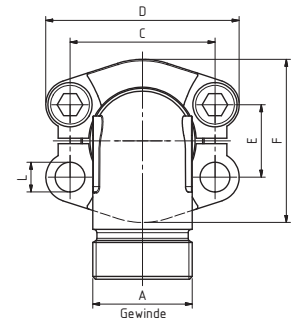
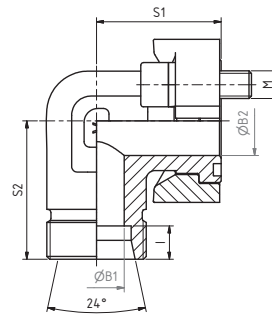

Bestellbezeichnung: ordering code:	S355J2^{*1}	1.4404^{*1} 316L
• nur 90° Zwischenstück only 90° elbow	WFG-...	WFG-X-...
• incl. Flanschhälften, Schraubensatz und O-Ring including split flanges, bolts and o-ring	WFG-...M	WFG-X-...MX
• incl. Flanschhälften, Schrauben- satz, O-Ring, Schneidring und Überwurfmutter including split flanges, bolts, o-ring, cutting ring and nut	WFG-...MM	WFG-X-...MMX

DIN 3901
Bohrungsform W / Drill form W

maximaler Betriebsdruck maximum recommended working pressure	S.A.E. Baugröße nominal flange size	Typ type	Abmessungen dimensions											Schrauben bolts	Gewicht weight	
			A	B1	B2	C	D	E	F	I	L	S1	S2			M
kg/cm ²	inch															
Schraube Festigkeitskl.			Standarddruckreihe / Standard pressure													
10.9																
315	1/2"	WFG 3001/L15	M 22x1,5	12	11	38,1	54	17,5	46	7,0	8,50	39	36	M 8x25	0,39	
350	1/2"	WFG 3001/S16	M 24x1,5	12	12	38,1	54	17,5	46	8,5	8,50	39	38	M 8x25	0,43	
315	3/4"	WFG 3002/L18	M 26x1,5	15	19	47,6	65	22,3	52	7,5	10,50	42	39	M 10x30	0,63	
160	3/4"	WFG 3002/L22	M 30x2	19	19	47,6	65	22,3	52	7,5	10,50	42	41	M 10x30	0,66	
350	3/4"	WFG 3002/S20	M 30x2	16	19	47,6	65	22,3	52	10,5	10,50	42	43	M 10x30	0,71	
350	3/4"	WFG 3002/S25	M 36x2	17	19	47,6	65	22,3	52	12,0	10,50	42	45	M 10x30	0,84	
160	1"	WFG 3003/L28	M 36x2	24	25	52,4	70	26,2	59	7,5	10,50	45	44	M 10x30	0,82	
320	1"	WFG 3003/S25	M 36x2	20	25	52,4	70	26,2	59	12,0	10,50	45	50	M 10x30	0,94	
320	1"	WFG 3003/S30	M 42x2	24	25	52,4	70	26,2	59	13,5	10,50	45	47	M 10x30	1,02	
160	1 1/4"	WFG 3004/L35	M 45x2	30	27	58,7	79	30,2	73	10,5	*2	50	57	*3	1,19	
280	1 1/4"	WFG 3004/S25	M 36x2	20	27	58,7	79	30,2	73	12,0	*2	50	55	*3	1,40	
280	1 1/4"	WFG 3004/S30	M 42x2	25	27	58,7	79	30,2	73	13,5	*2	50	57	*3	1,48	
280	1 1/4"	WFG 3004/S38	M 52x2	28	27	58,7	79	30,2	73	16,0	*2	50	59	*3	1,55	
160	1 1/2"	WFG 3005/L42	M 52x2	36	36	69,9	94	35,7	83	11,0	13,30	55	58	M 12x35	1,97	
210	1 1/2"	WFG 3005/S38	M 52x2	32	32	69,9	94	35,7	83	16,0	13,30	55	64	M 12x35	2,12	
160	2"	WFG 3006/L42	M 52x2	36	45	77,8	102	42,9	97	11,0	13,30	108	80	M 12x35	2,69	
200	2"	WFG 3006/S38	M 52x2	32	45	77,8	102	42,9	97	16,0	13,30	108	80	M 12x35	2,77	

Oberfläche: CR-6: auslaufend/Neu: CR-6 frei / surface: CR-6: phase-out/Neu: CR-6 free
^{*1} oder vergleichbare Güte / or comparable material
^{*2} Schraubenbohrung 10,50, 12,00 oder 12,75 / Bolt housing of 10.50, 12.00 or 12.75
^{*3} wahlweise M 10x30 oder M 12x35 / choice of M 10x30 or M 12x35

Hinweis: Der angegebene Nenndruck ist nach der SAE J 518 C durch den Flansch bzw. nach der Verschraubung nach DIN 3861 festgelegt. / **Please note:** The maximum working pressure is fixed by SAE J 518 C on flange side or by the thread side to DIN 3861.

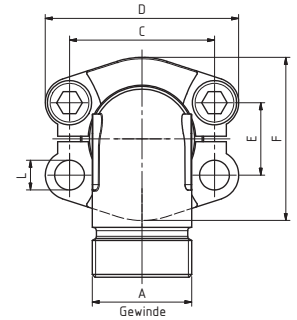
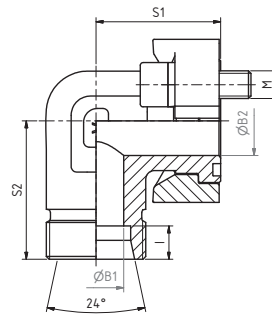

Bestellbezeichnung: ordering code:	S355J2^{*1}	1.4404^{*1} 316L
• nur 90° Zwischenstück only 90° elbow	WFG-...	WFG-X-...
• incl. Flanschhälften, Schraubensatz und O-Ring including split flanges, bolts and o-ring	WFG-...M	WFG-X-...MX
• incl. Flanschhälften, Schrauben- satz, O-Ring, Schneidring und Überwurfmutter including split flanges, bolts, o-ring, cutting ring and nut	WFG-...MM	WFG-X-...MMX

DIN 3901
Bohrungsform W / Drill form W

maximaler Betriebsdruck maximum recommended working pressure	S.A.E. Baugröße nominal flange size	Typ type	Abmessungen dimensions											Schrauben bolts	Gewicht weight		
			A	B1	B2	C	D	E	F	I	L	S1	S2			M	kg
kg/cm ²	inch																
Schraube Festigkeitskl. 10.9	Hochdruckreihe / High pressure																
420	1/2"	WFG 6001/S16	M 24x1,5	12	12	40,5	56	18,2	48	8,5	8,50	39	38	M 8x30	0,69		
420	3/4"	WFG 6002/S16	M 24x1,5	12	17	50,8	71	23,8	60	8,5	10,50	48	45	M 10x35	0,92		
420	3/4"	WFG 6002/S20	M 30x2	16	17	50,8	71	23,8	60	10,5	10,50	48	46	M 10x35	0,96		
420	3/4"	WFG 6002/S25	M 36x2	17	17	50,8	71	23,8	60	12,0	10,50	48	48	M 10x35	1,09		
420	1"	WFG 6003/S25	M 36x2	20	24	57,2	81	27,8	70	12,0	13,30	60	53	M 12x45	1,60		
420	1"	WFG 6003/S30	M 42x2	24	24	57,2	81	27,8	70	13,5	13,30	60	55	M 12x45	1,70		
420	1 1/4"	WFG 6004/S25	M 36x2	20	31	66,7	95	31,8	78	12,0	14,60	68	58	M 14x50	2,08		
420	1 1/4"	WFG 6004/S25-M12	M 36x2	20	31	66,7	95	31,8	78	12,0	13,30	68	58	M 12x45	2,1		
420	1 1/4"	WFG 6004/S30	M 42x2	25	31	66,6	95	31,8	78	13,5	14,60	68	58	M 14x50	2,22		
420	1 1/4"	WFG 6004/S30-M12	M 42x2	25	31	66,6	95	31,8	78	13,5	13,30	68	58	M 12x45	-		
350	1 1/4"	WFG 6004/S38	M 52x2	28	31	66,6	95	31,8	78	16,0	14,60	68	63	M 14x50	2,32		
350	1 1/4"	WFG 6004/S38-M12	M 52x2	28	31	66,6	95	31,8	78	16,0	13,30	68	63	M 12x45	-		
350	1 1/2"	WFG 6005/S30	M 42x2	25	36	79,3	113	36,5	95	13,5	16,80	76	72	M 16x55	3,30		
350	1 1/2"	WFG 6005/S38	M 52x2	30	36	79,3	113	36,5	95	16,0	16,80	76	72	M 16x55	3,55		
315	2"	WFG 6006/S38	M 52x2	32	45	96,8	133	44,5	114	13,5	21,00	108	80	M 20x70	2,46		

Oberfläche: CR-6: auslaufend/Neu: CR-6 frei / surface: CR-6: phase-out/Neu: CR-6 free
^{*1} oder vergleichbare Güte / or comparable material
^{*2} Schraubenbohrung 10,75, 12,00 oder 12,75 / Bolt housing of 10.75, 12.00 or 12.75
^{*3} wahlweise M 10x30 oder M 12x35 / choice of M 10x30 or M 12x35

Hinweis: Der angegebene Nenndruck ist nach der SAE J 518 C durch den Flansch bzw. nach der Verschraubung nach DIN 3861 festgelegt. / **Please note:** The maximum working pressure is fixed by SAE J 518 C on flange side or by the thread side to DIN 3861.

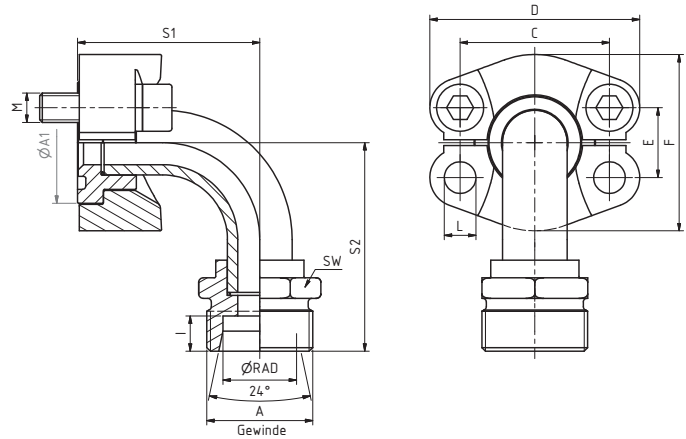

Bestellbezeichnung: ordering code:	9SMPb28K^{*1} ST37 ^{*1}
<ul style="list-style-type: none"> nur Zwischenstück adapter only 	SFCE-...
<ul style="list-style-type: none"> incl. Flanschhälften, metrischem Schraubensatz und O-Ring (Mutter und Schneidring) including split flanges, metric bolts and o-ring (nut and cutting ring) 	SFCE-...M(M)
<ul style="list-style-type: none"> incl. Flanschhälften, UNC-Schraubensatz und O-Ring (Mutter und Schneidring) including split flanges, UNC bolts and o-ring (nut and cutting ring) 	SFCE-...U(M)

maximaler Betriebsdruck maximum recommended working pressure	S.A.E. Baugröße nominal flange size	Typ/RAD type/RAD	Abmessungen dimensions											Schrauben bolts		Gewicht (nur Zwischenstück) weight (adapter only)		
			A	A1	C	D	E	F	I	S1	S2	SW	L	M			kg	
kg/cm ²	inch																	
Schraube Festigkeitskl. 10.9		Standarddruckreihe / Standard pressure														metr.	unc.	
315	1/2"	SFCE 3001/90-L15	M 22x1,5	30,2	38,1	54	17,5	46	7,0	40	50	22	8,50	M 8x25	5/16 x 1 1/4	0,14		
350	1/2"	SFCE 3001/90-S16	M 24x1,5	30,2	38,1	54	17,5	46	8,5	40	50	24	8,50	M 8x25	5/16 x 1 1/4	0,15		
160	3/4"	SFCE 3002/90-L22	M 30x2	38,1	47,6	65	22,3	52	7,5	59	71	32	10,50	M 10x30	3/8 x 1 1/4	0,29		
160	1"	SFCE 3003/90-L28	M 36x2	44,5	52,4	70	26,2	59	7,5	68	83	36	10,50	M 10x30	3/8 x 1 1/4	0,43		
320	1"	SFCE 3003/90-S25	M 36x2	44,5	52,4	70	26,2	59	12,0	68	83	36	10,50	M 10x30	3/8 x 1 1/4	0,38		
320	1"	SFCE 3003/90-S30	M 42x2	44,5	52,4	70	26,2	59	13,5	68	83	46	10,50	M 10x30	3/8 x 1 1/4	0,55		
160	1 1/4"	SFCE 3004/90-L35	M 45x2	50,8	58,7	79	30,2	73	10,5	86	105	46	*2	*3	7/16 x 1 1/2	0,76		
210	1 1/4"	SFCE 3004/90-S30	M 42x2	50,8	58,7	79	30,2	73	13,5	86	105	46	*2	*3	7/16 x 1 1/2	0,83		
160	1 1/2"	SFCE 3005/90-L42	M 52x2	60,3	69,9	94	35,7	83	11,0	98	115	55	13,30	M 12x35	1/2 x 1 1/2	0,99		
210	1 1/2"	SFCE 3005/90-S38	M 52x2	60,3	69,9	94	35,7	83	16,0	98	115	55	13,30	M 12x35	1/2 x 1 1/2	0,95		
Schraube Festigkeitskl. 10.9		Hochdruckreihe / High pressure														metr.	unc.	
420	1/2"	SFCE 6001/90-S16	M 24x1,5	31,8	40,5	56	18,2	48	8,5	42	52	24	8,50	M 8x30	5/16 x 1 1/4	0,16		
420	3/4"	SFCE 6002/90-S25	M 36x2	41,3	50,8	71	23,8	60	12,0	62	71	36	10,50	M 10x35	3/8 x 1 1/2	0,37		
420	3/4"	SFCE 6002/90-S30	M 42x2	41,3	50,8	71	23,8	60	13,5	62	71	46	10,50	M 10x35	3/8 x 1 1/2	0,49		
420	1"	SFCE 6003/90-S25	M 36x2	47,6	57,2	81	27,8	70	12,0	74	85	36	*4	M 12x45	7/16 x 1 3/4	0,43		
420	1"	SFCE 6003/90-S30	M 42x2	47,6	57,2	81	27,8	70	13,5	74	85	46	*4	M 12x45	7/16 x 1 3/4	0,59		
315	1 1/4"	SFCE 6004/90-S38	M 52x2	54,0	66,6	95	31,8	78	16,0	96	108	55	*5	*6	1/2 x 1 3/4	0,95		
315	1 1/2"	SFCE 6005/90-S38	M 52x2	63,5	79,3	113	36,5	95	16,0	112	114	55	16,80	M 16x55	5/8 x 2	1,13		

Oberfläche: CR-6: auslaufend/Neu: CR-6 frei / surface: CR-6: phase-out/Neu: CR-6 free

*1 oder vergleichbare Güte / or comparable material

*2 wahlweise 10,50, 12,00 oder 12,75 / choice of 10.50, 12.00 or 12.75

*3 wahlweise M 10x30 oder M 12x35 / choice of M 10x30 or M 12x35

*4 wahlweise 12,0 oder 13,0 / choice of 12.0 or 13.0

*5 wahlweise 13,3 oder 14,75 / choice of 13.3 or 14.75

*6 wahlweise M 12x45 oder M 14x50 / ...

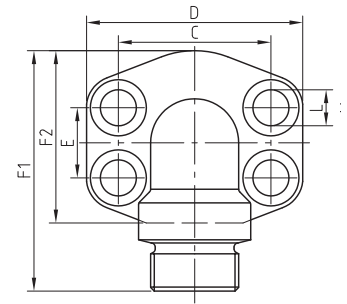
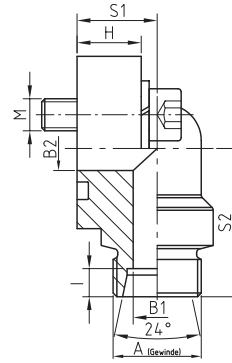

Bestellbezeichnung: ordering code:	S355J2*1
• nur Flansch flange only	AFG-.../90M...
• incl. metrischem Schraubensatz und O-Ring including metric bolts and o-ring	AFG-.../90M...M
• incl. UNC-Schraubensatz und O-Ring including UNC bolts and o-ring	AFG-.../90M...U

maximaler Betriebsdruck maximum recommended working pressure	S.A.E. Baugröße nominal flange size	Typ type	Abmessungen dimensions													Schrauben bolts		Gewicht weight
			A	B1	B2	C	D	E	F1	F2	H	I	S1	S2	L	M		
kg/cm ²	inch															metr.	unc.	
Schraube Festigkeitskl. 10.9			Standarddruckreihe / Standard pressure															
350	1/2"	AFG-080/90M-L15	M 22x1,5	12	13	38,1	54	17,5	60	43	16	7,0	20	37	9,0	M 8x30	5/16 x 1 1/4	0,27
350	1/2"	AFG-080/90M-S16	M 24x1,5	12	13	38,1	54	17,5	60	43	16	8,5	20	37	9,0	M 8x30	5/16 x 1 1/4	0,27
350	3/4"	AFG-100/90M-L18	M 26x1,5	15	19	47,6	65	22,3	63	47	18	7,5	24	38	11,0	M 10x35	3/8 x 1 1/2	0,46
350	3/4"	AFG-100/90M-L22	M 30x2	19	19	47,6	65	22,3	63	47	18	7,5	24	38	11,0	M 10x35	3/8 x 1 1/2	0,39
350	3/4"	AFG-100/90M-S16	M 24x1,5	12	19	47,6	65	22,3	63	47	18	8,5	24	38	11,0	M 10x35	3/8 x 1 1/2	0,42
350	3/4"	AFG-100/90M-S20	M 30x2	16	19	47,6	65	22,3	63	47	18	10,5	24	38	11,0	M 10x35	3/8 x 1 1/2	0,52
320	1"	AFG-102/90M-L28	M 36x2	24	25	52,4	70	26,2	70	51	19	7,5	28	43	11,0	M 10x35	3/8 x 1 1/2	0,54
320	1"	AFG-102/90M-S25	M 36x2	20	25	52,4	70	26,2	70	51	19	12,0	28	43	11,0	M 10x35	3/8 x 1 1/2	0,55
280	1 1/4"	AFG-104/90M-L28	M 36x2	24	32	58,7	79	30,2	85	64	21	7,5	34	51	11,5	M 10x40	7/16 x 1 1/2	0,86
280	1 1/4"	AFG-104/90M-L35	M 45x2	27	32	58,7	79	30,2	85	64	21	10,5	34	51	11,5	M 10x40	7/16 x 1 1/2	0,78
280	1 1/4"	AFG-104/90M-S25	M 36x2	20	32	58,7	79	30,2	85	64	21	12,0	34	51	11,5	M 10x40	7/16 x 1 1/2	0,86
280	1 1/4"	AFG-104/90M-S30	M 42x2	25	32	58,7	79	30,2	85	64	21	13,5	34	51	11,5	M 10x40	7/16 x 1 1/2	0,82
200	1 1/2"	AFG-106/90M-L42	M 52x2	36	38	69,9	93	35,7	96	74	25	11,0	38	57	13,5	M 12x45	1/2 x 1 3/4	1,28
200	1 1/2"	AFG-106/90M-S38	M 52x2	32	38	69,9	93	35,7	98	73	25	16,0	38	59	13,5	M 12x45	1/2 x 1 3/4	1,36
Schraube Festigkeitskl. 10.9			Hochdruckreihe / High pressure															
420	1/2"	AFG-401/90M-S16	M 24x1,5	12	13	40,5	54	18,2	60	43	16	8,5	20	37	9	M 8x30	5/16 x 1 1/4	0,40
420	3/4"	AFG-402/90M-S16	M 24x1,5	12	19	50,8	70	23,8	70	51	19	8,5	28	43	11	M 10x35	3/8 x 1 1/2	0,63
420	3/4"	AFG-402/90M-S20	M 30x2	16	19	50,8	70	23,8	70	51	19	10,5	28	43	11	M 10x35	3/8 x 1 1/2	0,60
420	3/4"	AFG-402/90M-S25	M 36x2	20	19	50,8	70	23,8	70	51	19	12,0	28	43	11	M 10x35	3/8 x 1 1/2	0,60
420	1"	AFG-403/90M-S25	M 36x2	20	25	57,2	79	27,8	85	64	21	12,0	34	51	13	M 12x45	7/16 x 1 3/4	0,93
420	1"	AFG-403/90M-S30	M 42x2	25	25	57,2	79	27,8	86	65	21	13,5	34	52	13	M 12x45	7/16 x 1 3/4	0,91
420	1 1/4"	AFG-404/90M-S30	M 42x2	25	29	66,6	94	31,8	96	74	25	13,5	38	57	15	M 14x50	–	1,49
420	1 1/4"	AFG-404/90M-S38	M 52x2	29	29	66,6	94	31,8	100	74	25	16,0	38	61	15	M 14x50	–	1,53
420	1 1/2"	AFG-405/90M-S38	M 52x2	29	38	79,3	110	36,5	100	85	25	16,0	42	65	17	M 16x50	5/8 x 2	2,26

*1 oder vergleichbare Güte / or comparable material

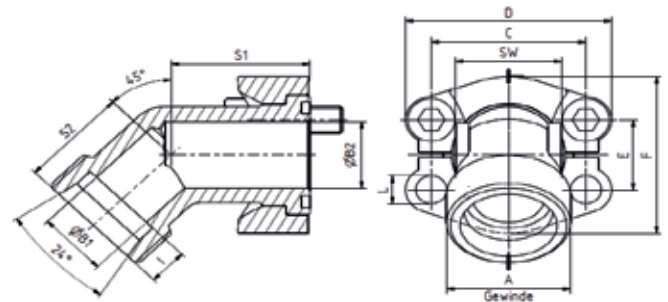

Bestellbezeichnung: ordering code:	S355J2^{*1}	1.4404^{*1}
• nur 45° Flansch-Adapter only 45° flange-adapter	WFG-...-45-...	WFG-X-...-45-...
• incl. Flanschhälften, Schraubensatz und O-Ring including split flanges, bolts and o-ring	WFG-...-45-...M	WFG-X-...-45-...MX
• incl. Flanschhälften, Schraubensatz, O-Ring, Schneidring und Überwurfmutter including split flanges, bolts, o-ring, cutting ring and nut	WFG-...-45-...MM	WFG-X-...-45-...MMX

maximaler Betriebsdruck maximum recommended working pressure	S.A.E. Baugröße nominal flange size	Typ type	Abmessungen dimensions												Schrauben bolts	Gewicht weight	
			A	B1	B2	C	D	E	F	I	L	S1	S2	SW			M
10,9		Standarddruckreihe / Standard pressure															
315	1/2"	WFG-3001-45-L15	M22x1,5	12	12	38,1	54	17,5	46	7	8,5	39	32,5	24	M8x25	0,19	
350		WFG-3001-45-S16	M24x1,5	12	12	38,1	54	17,5	46	8,5	8,5	39	32,5	24	M8x25	0,19	
315	3/4"	WFG-3002-45-L18	M26x1,5	15	19	47,6	65	22,2	52	7,5	10,5	40,15	32,5	30	M10x30	0,27	
160		WFG-3002-45-L22	M30x2	19	19	47,6	65	22,2	52	7,5	10,5	40,15	32,5	30	M10x30	0,26	
350		WFG-3002-45-S20	M30x2	16	19	47,6	65	22,2	52	10,5	10,5	40,15	32,5	30	M10x30	0,28	
350		WFG-3002-45-S25	M36x2	20	19	47,6	65	22,2	52	12,0	10,5	40,15	32,5	30	M10x30	0,28	
160	1"	WFG-3003-45-L28	M36x2	24	25	52,4	70	26,2	59	7,5	10,5	47	37,35	36	M10x30	0,39	
250		WFG-3003-45-S25	M36x2	20	25	52,4	70	26,2	59	12,0	10,5	47	37,35	36	M10x30	0,42	
250		WFG-3003-45-S30	M42x2	24	25	52,4	70	26,2	59	13,5	10,5	47	37,35	36	M10x30	0,43	
160	1 1/4"	WFG-3004-45-L35	M45x2	27	27	58,7	79	30,2	73	10,5	*2	51,8	40,4	41	*3	0,6	
280		WFG-3004-45-S30	M42x2	25	27	58,7	79	30,2	73	13,5	*2	51,8	40,4	41	*3	0,61	
280		WFG-3004-45-S38	M52x2	27	27	58,7	79	30,2	73	16,0	*2	51,8	40,4	41	*3	0,66	
160	1 1/2"	WFG-3005-45-L42	M52x2	36	36	69,9	94	35,7	83	11,0	13,3	60,45	45,2	50	M12x35	0,83	
210		WFG-3005-45-S38	M52x2	30	36	69,9	94	35,7	83	16,0	13,3	60,45	45,2	50	M12x35	0,92	
		Hochdruckreihe / High pressure															
420	1/2"	WFG-6001-45-S16	M24x1,5	12	12	40,5	56,4	18,2	47,8	8,5	8,5	39	32,5	24	M8x30	0,2	
420	3/4"	WFG-6002-45-S16	M24x1,5	12	17	50,8	71	23,8	61	8,5	10,5	40,15	32,5	32	M10x35	0,34	
420		WFG-6002-45-S20	M30x2	16	17	50,8	71	23,8	61	10,5	10,5	40,15	32,5	32	M10x35	0,34	
420		WFG-6002-45-S25	M36x2	20	17	50,8	71	23,8	61	12,0	10,5	40,15	32,5	32	M10x35	0,35	
420	1"	WFG-6003-45-S25	M36x2	20	24	57,2	81	27,8	70	12,0	13,3	47	37,35	41	M12x45	0,55	
420		WFG-6003-45-S30	M42x2	25	24	57,2	81	27,8	70	13,5	13,3	47	37,35	41	M12x45	0,55	
420	1 1/4"	WFG-6004-45-S30	M42x2	25	31	66,7	95	31,8	78	13,5	*4	51,8	40,4	46	*5	0,7	
350		WFG-6004-45-S38	M52x2	30	31	66,7	95	31,8	78	16,0	*4	51,8	40,4	46	*5	0,7	
350	1 1/2"	WFG-6005-45-S30	M42x2	25	36	79,4	113	36,5	95	13,5	16,8	60,45	45,2	50	M16x55	-	
350		WFG-6005-45-S38	M52x2	30	36	79,4	113	36,5	95	16,0	16,8	60,45	45,2	50	M16x55	1,0	

*1 oder vergleichbare Güte / or comparable material

*4 Schraubenbohrung 14,6 oder 13,3

*2 Schraubenbohrung 10,5; 12,0; 12,75 / bolt hole 10,5; 12,0; 12,75

*5 M14x50 oder M12x45

*3 M10x30 oder M12x35

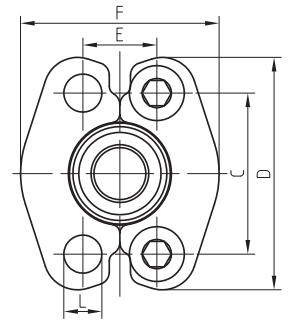
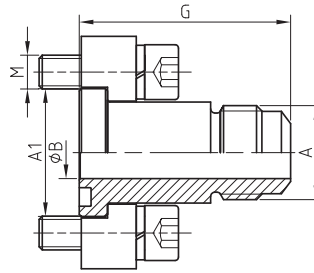

Bestellbezeichnung: ordering code:	S355J2^{*1} C22	1.4404^{*1} 316L
• nur Außengewindeflansch adaptor only	SFCE-...J	SFCE-X-...J
• incl. Flanschhälften, metrischem Schraubensatz und O-Ring including split flanges, metric bolts and o-ring	SFCE-...JM	SFCE-X-...J...MX
• incl. Flanschhälften, UNC-Schraubensatz und O-Ring including split flanges, UNC bolts and o-ring	SFCE-...JU	SFCE-X-...J...UX

maximaler Betriebsdruck maximum recommended working pressure	S.A.E. Baugröße nominal flange size	Typ type	Abmessungen dimensions											Schrauben bolts		Gewicht weight		
			A	A1	B	C	D	E	F	G	SW	L	M	kg				
kg/cm ²	inch															metr.	unc.	
Schraube Festigkeitskl. 10.9															Standarddruckreihe / Standard pressure			
350	1/2"	SFCE 3001-J 7/8	7/8" -14UN	30,2	12,3	38,1	54	17,5	46	48	20	8,50	M 8x25	5/16 x 1 1/4	-			
350	3/4"	SFCE 3002-J 1 1/16	1 1/16" -12UN	38,1	15,5	47,6	65	22,3	52	55	30	10,50	M 10x30	3/8 x 1 1/4	-			
320	1"	SFCE 3003-J 1 1/16	1 1/16" -12UN	44,5	15,5	52,4	70	26,2	59	55	36	10,50	M 10x30	3/8 x 1 1/4	-			
280	1 1/4"	SFCE 3004-J 1 5/16	1 5/16" -12UN	50,8	21,5	58,7	79	30,2	73	58	42	*2	*3	7/16 x 1 1/2	-			
280	1 1/4"	SFCE 3004-J 1 5/8	1 5/8" -12UN	50,8	27,5	58,7	79	30,2	73	58	42	*2	*3	7/16 x 1 1/2	-			
210	1 1/2"	SFCE 3005-J 1 7/8	1 7/8" -12UN	60,3	33,0	69,9	94	35,7	83	62	42	13,30	M 12x35	1/2 x 1 1/2	-			
Schraube Festigkeitskl. 10.9															Hochdruckreihe / High pressure			
350	1/2"	SFCE 6001-J 1 1/16	1 1/16" -12UN	31,8	15,5	40,5	56	18,2	48	50	20	8,50	M 8x30	5/16 x 1 1/4	-			
350	1/2"	SFCE 6001-J 7/8	7/8" -14UN	31,8	12,3	40,5	56	18,2	48	50	20	8,50	M 8x30	5/16 x 1 1/4	-			
350	1/2"	SFCE 6001-J 3/4	3/4" -16UN	31,8	9,9	40,5	56	18,2	48	50	20	8,50	M 8x30	5/16 x 1 1/4	-			
350	3/4"	SFCE 6002-J 1 1/16	1 1/16" -12UN	41,3	15,5	50,8	71	23,8	60	64	30	10,50	M 10x35	3/8 x 1 1/2	-			
350	1"	SFCE 6003-J 1 1/16	1 1/16" -12UN	47,6	15,5	57,2	81	27,8	70	72	36	*4	M 12x45	7/16 x 1 1/2	-			
350	1"	SFCE 6003-J 1 5/16	1 5/16" -12UN	47,6	21,5	57,2	81	27,8	70	72	36	*4	M 12x45	7/16 x 1 1/2	-			
350	1 1/4"	SFCE 6004-J 1 5/16	1 5/16" -12UN	54,0	21,5	66,6	95	31,8	78	81	41	14,60	M 14x50	-	-			
350	1 1/4"	SFCE 6004-J 1 5/16-M12	1 5/16" -12UN	54,0	21,5	66,6	95	31,8	78	81	41	13,30	M 12x45	1/2 x 1 3/4	-			
275	1 1/4"	SFCE 6004-J 1 5/8	1 5/8" -12UN	54,0	27,5	66,6	95	31,8	78	81	41	14,60	M 14x50	-	-			
275	1 1/4"	SFCE 6004-J 1 5/8-M12	1 5/8" -12UN	54,0	27,5	66,6	95	31,8	78	81	41	13,30	M 12x45	1/2 x 1 3/4	-			
275	1 1/2"	SFCE 6005-J 1 5/8	1 5/8" -12UN	63,5	27,5	79,3	113	36,5	95	86	41	16,80	M 16x55	5/8 x 2	-			
210	1 1/2"	SFCE 6005-J 1 7/8	1 7/8" -12UN	63,5	33,0	79,3	113	36,5	95	86	42	16,80	M 16x55	5/8 x 2	-			

Oberfläche: CR-6: auslaufend/Neu: CR-6 frei / surface: CR-6: phase-out/New: CR-6 free
*1 oder vergleichbare Güte / or comparable material

*2 wahlweise 10,50, 12,00 oder 12,75 / choice of 10.50, 12.00 or 12.75

*3 wahlweise M 10x30 oder M 12x35 / choice of M 10x30 or M 12x35

*4 wahlweise 12,0 oder 13,0 / choice of 12.0 or 13.0

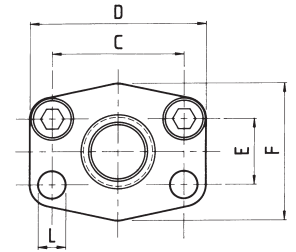
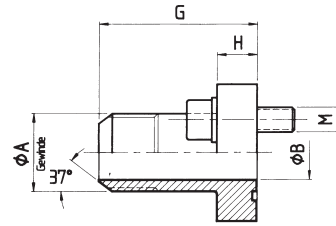

Bestellbezeichnung: ordering code:	S355J2^{*1}
• nur Flansch flange only	AFG-...
• incl. metrischem Schraubensatz und O-Ring including metric bolts and o-ring	AFG-...M
• incl. UNC-Schraubensatz und O-Ring including UNC bolts and o-ring	AFG-...U

maximaler Betriebsdruck maximum recommended working pressure	S.A.E. Baugröße nominal flange size	Typ type	Abmessungen dimensions									Schrauben bolts		Gewicht weight	
			A	B	C	D	E	F	G	H	L	M	kg		
kg/cm ²	inch														
Schraube Festigkeitskl. 10.9	Standarddruckreihe / Standard pressure											metr.	unc.		
350	1/2"	AFG 080 JIC 3/4	3/4" -16 JIC	9,9	38,1	54	17,5	46	52	13	9,0	M 8x30	5/16 x 1 1/4	0,25	
350	1/2"	AFG 080 JIC 7/8	7/8" -14 JIC	12,3	38,1	54	17,5	46	52	13	9,0	M 8x30	3/8 x 1 1/4	0,30	
350	3/4"	AFG 100 JIC 1 1/16	1 1/16" -12 JIC	15,5	47,6	65	22,3	50	60	14	11,5	M 10x30	3/8 x 1 1/4	0,35	
320	1"	AFG 102 JIC 1 5/16	1 5/16" -12 JIC	21,5	52,4	70	26,2	55	63	16	11,5	M 10x30	3/8 x 1 1/4	0,50	
280	1 1/4"	AFG 104 JIC 1 5/8	1 5/8" -12 JIC	27,5	58,7	79	30,2	68	65	14	11,5	M 10x30	7/16 x 1 1/2	0,70	
280	1 1/4"	AFG 104 JIC 1 5/16	1 5/16" -12 JIC	21,5	58,7	79	30,2	68	65	14	11,5	M 10x30	7/16 x 1 1/2	0,70	
210	1 1/2"	AFG 106 JIC 1 7/8	1 7/8" -12 JIC	33,0	69,9	94	35,7	78	70	16	13,5	M 12x35	1/2 x 1 1/2	1,00	

*1 oder vergleichbare Güte / or comparable material

*2 L=13,5 für UNC-Schrauben / L=13.5 with UNC-bolts

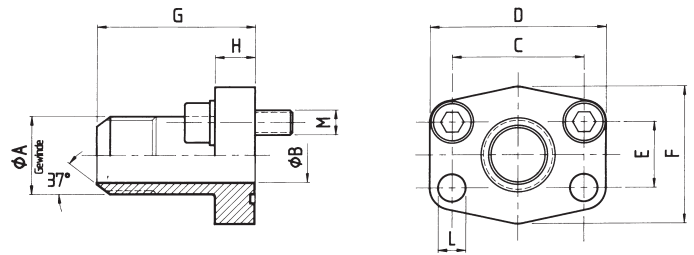

Bestellbezeichnung: ordering code:	S355J2^{*1}
• nur Flansch flange only	AFG-...
• incl. metrischem Schraubensatz und O-Ring including metric bolts and o-ring	AFG-...M
• incl. UNC-Schraubensatz und O-Ring including UNC bolts and o-ring	AFG-...U

maximaler Betriebsdruck maximum recommended working pressure	S.A.E. Baugröße nominal flange size	Typ type	Abmessungen dimensions									Schrauben bolts		Gewicht weight	
			A	B	C	D	E	F	G	H	L	M	kg		
kg/cm ²	inch														
Schraube Festigkeitskl. 10.9	Hochdruckreihe / High pressure											metr.	unc.		
420	1/2"	AFG 401 JIC 3/4	3/4" -16 JIC	9,9	40,5	56	18,2	48	60	16	9,0	M 8x30	5/16 x 1 1/4	0,30	
420	1/2"	AFG 401 JIC 7/8	7/8" -14 JIC	12,3	40,5	56	18,2	48	60	16	9,0	M 8x30	5/16 x 1 1/4	0,40	
420	3/4"	AFG 402 JIC 1 1/16	1 1/16" -12 JIC	15,5	50,8	71	23,8	60	73	19	11,5	M 10x35	3/8 x 1 1/2	0,70	
420	1"	AFG 403 JIC 1 5/16	1 5/16" -12 JIC	21,5	57,2	81	27,8	70	82	24	13,0	M 12x45	7/16 x 1 3/4	1,00	
420	1 1/4"	AFG 404 JIC 1 5/8	1 5/8" -12 JIC	27,5	66,6	95	31,8	78	92	27	15,0 ^{*2}	M 14x50	1/2 x 1 3/4	1,50	
420	1 1/4"	AFG 404 JIC 1 5/16	1 5/16" -12 JIC	21,5	66,6	95	31,8	78	92	27	15,0 ^{*2}	M 14x50	1/2 x 1 3/4	1,50	
420	1 1/2"	AFG 405 JIC 1 7/8	1 7/8" -12 JIC	33,0	79,3	113	36,5	95	96	30	17,5	M 16x55	5/8 x 2	2,30	

*1 oder vergleichbare Güte / or comparable material

*2 L=13,5 für UNC-Schrauben / L=13.5 with UNC-bolts

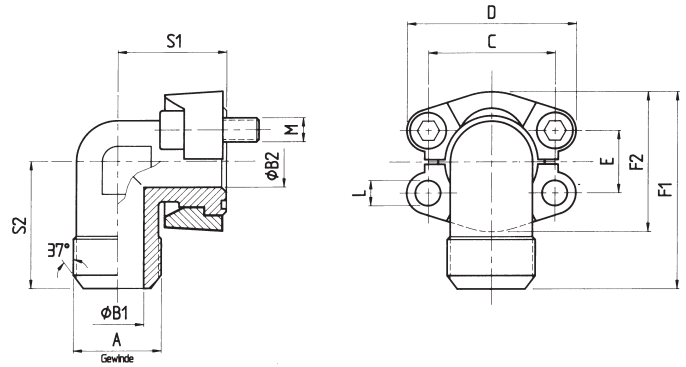

Bestellbezeichnung: ordering code:	S355J2^{*1}	1.4404^{*1} 316L
• nur 90° Zwischenstück only 90° elbow	WFG-...	WFG-X-...
• incl. Flanschhälften, Schraubensatz (metrisch) und O-Ring including split flanges, metric bolts and o-ring	WFG-...M	WFG-X-...MX
• incl. Flanschhälften, UNC-Schraubensatz und O-Ring including split flanges, UNC bolts and o-ring	WFG-...U	WFG-X-...UX

maximaler Betriebsdruck maximum recommended working pressure	S.A.E. Baugröße nominal flange size	Typ type	Abmessungen dimensions											Schrauben bolts		Gewicht weight			
			A	B1	B2	C	D	E	F1	F2	S1	S2	L	M	kg				
kg/cm ²	inch																		
Schraube Festigkeitskl.		Standarddruckreihe / Standard pressure															metr.	unc.	
10.9																			
350	1/2"	WFG 3001 JIC 3/4	3/4 -16 JIC	9,9	13	38,1	54	17,5	60,8	46	38	38	8,50	M 8x25	5/16 x 1 1/4	0,34			
350	1/2"	WFG 3001 JIC 7/8	7/8 -14 JIC	12,3	13	38,1	54	17,5	60,8	46	38	38	8,50	M 8x25	5/16 x 1 1/4	0,40			
350	3/4"	WFG 3002 JIC 7/8	7/8 -14 JIC	12,3	19	47,6	65	22,3	70,9	52	42	45	10,50	M 10x30	3/8 x 1 1/2	0,60			
350	3/4"	WFG 3002 JIC 1 1/16	1 1/16 -12 JIC	15,5	19	47,6	65	22,3	70,9	52	42	45	10,50	M 10x30	3/8 x 1 1/2	0,63			
350	3/4"	WFG 3002 JIC 1 5/16	1 5/16 -12 JIC	21,5	19	47,6	65	22,3	70,9	52	42	45	10,50	M 10x30	3/8 x 1 1/2	0,66			
320	1"	WFG 3003 JIC 1 1/16	1 1/16 -12 JIC	15,5	24	52,4	70	26,2	79,2	59	45	50	10,50	M 10x30	3/8 x 1 1/2	0,80			
320	1"	WFG 3003 JIC 1 5/16	1 5/16 -12 JIC	21,5	25	52,4	70	26,2	79,2	59	45	52	10,50	M 10x30	3/8 x 1 1/2	0,85			
320	1"	WFG 3003 JIC 1 3/8	1 3/8 -12 JIC	27,5	25	52,4	70	26,2	79,2	59	45	52	10,50	M 10x30	3/8 x 1 1/2	0,89			
280	1 1/4"	WFG 3004 JIC 1 5/16	1 5/16 -12 JIC	21,5	24	58,7	79	30,2	85,3	73	50	59	*2	*3	7/16 x 1 1/2	1,16			
280	1 1/4"	WFG 3004 JIC 1 3/8	1 3/8 -12 JIC	27,5	31	58,7	79	30,2	85,3	73	50	59	*2	*3	7/16 x 1 1/2	1,27			
210	1 1/2"	WFG 3005 JIC 1 3/8	1 3/8 -12 JIC	27,5	38	69,9	94	35,7	117,1	83	76	76	13,30	M 12x35	1/2 x 1 1/2	1,90			
210	1 1/2"	WFG 3005 JIC 1 7/8	1 7/8 -12 JIC	33,0	38	69,9	94	35,7	117,1	83	76	76	13,30	M 12x35	1/2 x 1 1/2	2,05			
210	2"	WFG 3006 JIC 1 7/8	1 7/8 -12 JIC	33,0	45	77,8	102	42,9	128,5	97,0	108	80	13,30	M 12x35	1/2 x 1 1/2	-			
210	2"	WFG 3006 JIC 2 1/2	2 1/2 -12 JIC	45,0	45	77,8	102	42,9	128,5	97,0	108	80	13,30	M 12x35	1/2 x 1 1/2	-			

Oberfläche: CR-6: auslaufend/Neu: CR-6 frei / surface: CR-6: phase-out/Neu: CR-6 free
*1 oder vergleichbare Güte / or comparable material

*2 wahlweise 10,50, 12,00 oder 12,75 / choice of 10.50, 12.00 or 12.75
*3 wahlweise M 10x30 oder M 12x35 / choice of M 10x30 or M 12x35

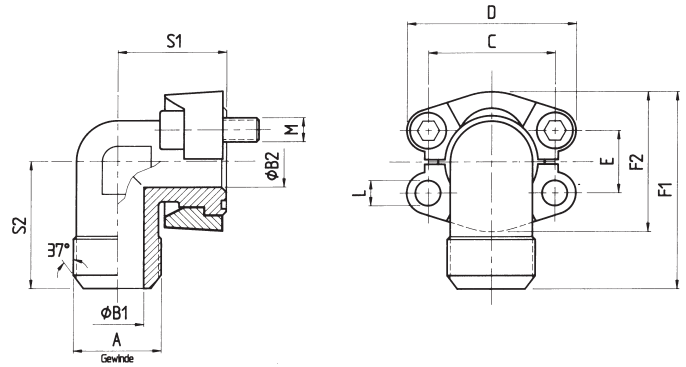

Bestellbezeichnung: ordering code:	S355J2^{*1}	1.4404^{*1} 316L
• nur 90° Zwischenstück only 90° elbow	WFG-...	WFG-X-...
• incl. Flanschhälften, Schraubensatz (metrisch) und O-Ring including split flanges, metric bolts and o-ring	WFG-...M	WFG-X-...MX
• incl. Flanschhälften, UNC-Schraubensatz und O-Ring including split flanges, UNC bolts and o-ring	WFG-...U	WFG-X-...UX

maximaler Betriebsdruck maximum recommended working pressure	S.A.E. Baugröße nominal flange size	Typ type	Abmessungen dimensions											Schrauben bolts		Gewicht weight
			A	B1	B2	C	D	E	F1	F2	S1	S2	L	M	kg	
kg/cm ²	inch													metr.	unc.	
Schraube Festigkeitskl.			Hochdruckreihe / High pressure													
10,9																
420	1/2"	WFG 6001 JIC 3/4	3/4 -16 JIC	9,9	13	40,5	56	18,2	61,6	48	39	38	8,50	M 8x30	5/16 x 1 1/4	0,37
420	1/2"	WFG 6001 JIC 7/8	7/8 -14 JIC	12,3	13	40,5	56	18,2	61,6	48	39	38	8,50	M 8x35	5/16 x 1 1/4	0,45
420	3/4"	WFG 6002 JIC 7/8	7/8 -14 JIC	12,3	17	50,8	71	23,8	78,0	60	48	48	10,50	M 10x35	3/8 x 1 1/2	0,88
420	3/4"	WFG 6002 JIC 1 1/16	1 1/16 -12 JIC	15,5	17	50,8	71	23,8	78,0	60	48	48	10,50	M 10x35	3/8 x 1 1/2	0,97
420	3/4"	WFG 6002 JIC 1 5/16	1 5/16 -12 JIC	21,5	17	50,8	71	23,8	78,0	60	48	48	10,50	M 10x35	3/8 x 1 1/2	1,02
420	1"	WFG 6003 JIC 1 1/16	1 1/16 -12 JIC	15,5	24	57,2	81	27,8	99,0	70	60	60	*2	M 12x45	7/16 x 1 3/4	1,46
420	1"	WFG 6003 JIC 1 5/16	1 5/16 -12 JIC	21,5	24	57,2	81	27,8	99,0	70	60	60	*2	M 12x45	7/16 x 1 3/4	1,57
420	1"	WFG 6003 JIC 1 5/8	1 5/8 -12 JIC	27,5	24	57,2	81	27,8	99,0	70	60	60	*2	M 12x45	7/16 x 1 3/4	1,70
420	1 1/4"	WFG 6004 JIC 1 5/16	1 5/16 -12 JIC	21,5	31	66,6	95	31,8	115,5	78	68	68	*3	*4	1/2 x 1 3/4	2,20
420	1 1/4"	WFG 6004 JIC 1 5/8	1 5/8 -12 JIC	27,5	31	66,6	95	31,8	115,5	78	68	68	*3	*4	1/2 x 1 3/4	2,30
420	1 1/4"	WFG 6004 JIC 1 7/8	1 7/8 -12 JIC	33,0	30	66,6	95	31,8	115,5	78	68	68	*3	*4	1/2 x 1 3/4	2,45
420	1 1/2"	WFG 6005 JIC 1 5/8	1 5/8 -12 JIC	27,5	32	79,3	113	36,5	133,0	95	76	76	16,80	M 16x55	5/8 x 2	3,08
420	1 1/2"	WFG 6005 JIC 1 7/8	1 7/8 -12 JIC	33,0	36	79,3	113	36,5	133,0	95	76	76	16,80	M 16x55	5/8 x 2	3,45
420	2"	WFG 6006 JIC 1 7/8	1 7/8 -12 JIC	33,0	45	96,8	133	44,5	137,0	114	108	80	21	M 20x70	3/4 x 2 1/2	-
420	2"	WFG 6006 JIC 2 1/2	2 1/2 -12 JIC	45,0	45	96,8	133	44,5	137,0	114	108	80	21	M 20x70	3/4 x 2 1/2	-

Oberfläche: CR-6: auslaufend/Neu: CR-6 frei / surface: CR-6: phase-out/New: CR-6 free

*1 oder vergleichbare Güte / or comparable material

*2 wahlweise 12,0 oder 13,0 / choice of 12.0 or 13.0

*3 wahlweise 13,3 oder 14,6 / choice of 13.3 or 14.6

*4 wahlweise M 12x45 oder M 14x50

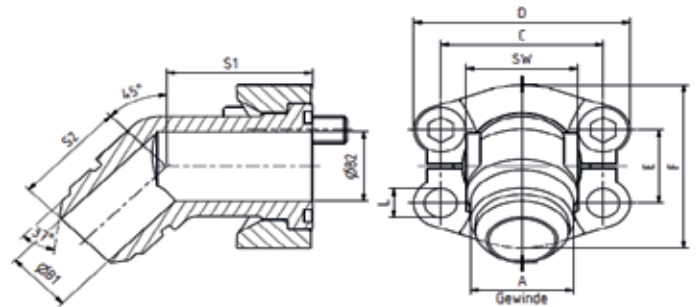

Bestellbezeichnung: ordering code:	S355J2^{*1}	1.4404^{*1}
• nur 45° Flansch-Adapter only 45° flange-adapter	WFG-...-45-J...	WFG-X-...-45-J...
• incl. Flanschhälften, Schraubensatz und O-Ring including split flanges, bolts and o-ring	WFG-...-45-J...M	WFG-X-...-45-J...MX

maximaler Betriebsdruck maximum recommended working pressure	S.A.E. Baugröße nominal flange size	Typ type	Abmessungen dimensions										Schrauben bolts	Gewicht weight			
			A	B1	B2	C	D	E	F	L	S1	S2			SW	M	kg
kg/cm ²	inch																
Schraube Festigkeitskl. 10.9																	
Standarddruckreihe / Standard pressure																	
350	1/2"	WFG-3001-45-J3/4	3/4"-16UNF	9,9	12	38,1	54	17,5	46	8,5	39	32,5	24	M8x25	–		
350		WFG-3001-45-J7/8	7/8"-14 UNF	12,3	12	38,1	54	17,5	46	8,5	39	32,5	24	M8x25	–		
350	3/4"	WFG-3002-45-J7/8	7/8"-14UNF	12,3	19	47,6	65	22,2	52	10,5	40,15	32,5	30	M10x30	–		
350		WFG-3002-45-J1.1/16	1 1/16"-12UN	15,5	19	47,6	65	22,2	52	10,5	40,15	32,5	30	M10x30	–		
320	1"	WFG-3003-45-J1.1/16	1 1/16"-12UN	15,5	25	52,4	70	26,2	59	10,5	47	37,35	36	M10x30	–		
320		WFG-3003-45-J1.5/16	1 5/16"-12UN	21,5	25	52,4	70	26,2	59	10,5	47	37,35	36	M10x30	–		
280	1 1/4"	WFG-3004-45-J1.5/16	1 5/16"-12UN	21,5	27	58,7	79	30,2	73	*2	51,8	40,4	41	*3	–		
280		WFG-3004-45-J1.5/8	1 5/8"-12UN	27,5	27	58,7	79	30,2	73	*2	51,8	40,4	41	*3	–		
210	1 1/2"	WFG-3005-45-J1.5/8	1 5/8"-12UN	27,5	36	69,9	94	35,7	83	13,3	60,45	45,2	50	M12x35	–		
210		WFG-3005-45-J1.7/8	1 7/8"-12UN	33	36	69,9	94	35,7	83	13,3	60,45	45,2	50	M12x35	–		
Schraube Festigkeitskl. 10.9																	
Hochdruckreihe / High pressure																	
420	1/2"	WFG-6001-45-J3/4	3/4"-16UNF	11,1	12	40,5	56,4	18,2	47,8	8,5	39	32,5	24	M8x30	–		
420		WFG-6001-45-J7/8	7/8"-14UNF	12,3	12	40,5	56,4	18,2	47,8	8,5	39	32,5	24	M8x30	–		
400	3/4"	WFG-6002-45-J7/8	7/8"-14UNF	12,3	17	50,8	71	23,8	61	10,5	40,15	32,5	32	M10x35	–		
400		WFG-6002-45-J1.1/16	1 1/16"-12UN	15,5	17	50,8	71	23,8	61	10,5	40,15	32,5	32	M10x35	–		
400	1"	WFG-6003-45-J1.1/16	1 1/16"-12UN	15,5	24	57,2	81	27,8	70	13,3	47	37,35	41	M12x45	–		
400		WFG-6003-45-J1.5/16	1 5/16"-12UN	21,5	24	57,2	81	27,8	70	13,3	47	37,35	41	M12x45	–		
400	1 1/4"	WFG-6004-45-J1.5/16	1 5/16"-12UN	21,5	31	66,7	95	31,8	78	*4	51,8	40,4	46	*5	–		
400		WFG-6004-45-J1.5/8	1 5/8"-12UN	27,5	31	66,7	95	31,8	78	*4	51,8	40,4	46	*5	–		
400	1 1/2"	WFG-6005-45-J1.5/8	1 5/8"-12UN	27,5	36	79,4	113	36,5	95	16,8	60,45	45,2	50	M16x55	–		
400		WFG-6005-45-J1.7/8	1 7/8"-12UN	33	36	79,4	113	36,5	95	16,8	60,45	45,2	50	M16x55	–		

*1 oder vergleichbare Güte / or comparable material

*2 Schraubenbohrung 10,5; 12,0; 12,75 / bolt hole 10,5; 12,0; 12,75

*3 M10x30 oder M12x35

*4 Schraubenbohrung 14,6 oder 13,3

*5 M14x50 oder M12x45

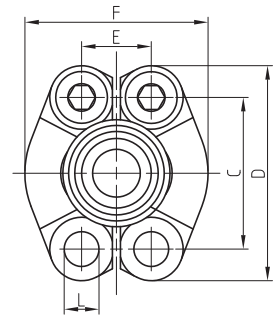
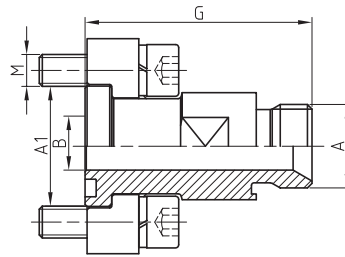

Bestellbezeichnung: ordering code:	S355J2^{*1}	1.4404^{*1} 316L
• nur Außengewindeflansch adaptor only	SFCE-...G	SFCE-X-...G
• incl. Flanschhälften, metrischem Schraubensatz und O-Ring including split flanges, metric bolts and o-ring	SFCE-...GM	SFCE-X-...GMX
• incl. Flanschhälften, UNC-Schrau- bensatz und O-Ring including split flanges, UNC bolts and o-ring	SFCE-...GU	SFCE-X-...GUX

maximaler Betriebsdruck maximum recommended working pressure	S.A.E. Baugröße nominal flange size	Typ type	Abmessungen dimensions										Schrauben bolts		Gewicht weight		
			A	A1	B	C	D	E	F	G	SW	L	M	kg			
kg/cm ²	inch																
Schraube Festigkeitskl.	Standarddruckreihe / Standard pressure														<i>metr.</i>	<i>unc.</i>	
10.9																	
350	1/2"	SFCE 3001-G012	G 1/2"	30,2	12,0	38,1	54	17,5	46	57	24	8,50	M 8x25	5/16 x 1 1/4	0,16		
350	3/4"	SFCE 3002-G034	G 3/4"	38,1	17,0	47,6	65	22,3	52	62	30	10,50	M 10x30	3/8 x 1 1/2	0,26		
320	1"	SFCE 3003-G100	G 1"	44,5	24,0	52,4	70	26,2	59	65	36	10,50	M 10x30	3/8 x 1 1/2	0,36		
280	1 1/4"	SFCE 3004-G114	G 1 1/4"	50,8	27,0	58,7	79	30,2	73	69	46	*2	*3	7/16 x 1 1/2	0,51		
210	1 1/2"	SFCE 3005-G112	G 1 1/2"	60,3	32,0	69,9	94	35,7	83	77	46	13,30	M 12x35	1/2 x 1 1/2	0,65		
210	2"	SFCE 3006-G200	G 2"	71,4	40,0	77,8	102	42,9	97	74	55	13,30	M 12x35	1/2 x 1 1/2	1,05		
Schraube Festigkeitskl.	Hochdruckreihe / High pressure														<i>metr.</i>	<i>unc.</i>	
10.9																	
420	1/2"	SFCE 6001-G012	G 1/2"	31,8	12,0	40,5	56	18,2	48	60	24	8,50	M 8x30	5/16 x 1 1/4	0,18		
420	3/4"	SFCE 6002-G034	G 3/4"	41,3	19,0	50,8	71	23,8	60	69	30	10,50	M 10x35	3/8 x 1 1/2	0,30		
420	1"	SFCE 6003-G100	G 1"	47,6	20,0	57,2	81	27,8	70	79	36	*4	M 12x45	7/16 x 1 1/2	0,45		
420	1 1/4"	SFCE 6004-G114	G 1 1/4"	54,0	30,0	66,6	95	31,8	78	88	46	14,60	M 14x50	-	0,67		
420	1 1/4"	SFCE 6004-G114-M12	G 1 1/4"	54,0	27,5	66,6	95	31,8	78	88	46	13,30	M 12x45	1/2 x 1 3/4	0,67		
420	1 1/2"	SFCE 6005-G112	G 1 1/2"	63,5	30,0	79,3	113	36,5	95	96	46	16,80	M 16x55	5/8 x 2	0,89		
420	2"	SFCE 6006-G200	G 2"	79,4	38,0	96,8	133	44,5	114	122	55	21,00	M 20x70	3/4 x 2 1/2	2,16		

Oberfläche: CR-6: auslaufend/Neu: CR-6 frei / surface: CR-6: phase-out/Neu: CR-6 free

*1 oder vergleichbare Güte / or comparable material

*2 wahlweise 10,5, 12,00 oder 12,75 / choice of 10.5, 12.00 or 12.75

*3 wahlweise M 10x30 oder M 12x35 / choice of M 10x30 or M 12x35

*4 wahlweise 12,0 oder 13,0 / choice of 12.0 or 13.0

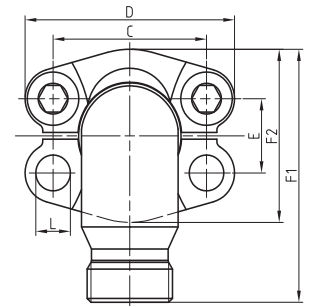
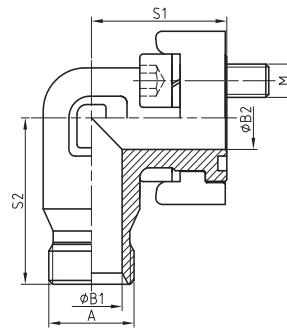

Bestellbezeichnung: ordering code:	S355J2^{*1}
• nur Flansch flange only	WFG-...G
• incl. Flanschhälften, metrischem Schraubensatz und O-Ring including split flanges, metric bolts and o-ring	WFG-...GM
• incl. Flanschhälften, UNC-Schraubensatz und O-Ring including split flanges, UNC bolts and o-ring	WFG-...GU

maximaler Betriebsdruck maximum recommended working pressure	S.A.E. Baugröße nominal flange size	Typ type	Abmessungen dimensions											Schrauben bolts		Gewicht weight			
			A	B1	B2	C	D	E	F1	F2	S1	S2	L	M	kg				
kg/cm ²	inch																		
Schraube Festigkeitskl.		Standarddruckreihe / Standard pressure													<i>metr.</i>	<i>unc.</i>			
10.9																			
350	1/2"	WFG 3001-G1/2	G 1/2"	11,0	11	38,1	54	17,5	63,0	46	39	40	8,50	M 8x25	5/16 x 1 1/4	0,18			
350	3/4"	WFG 3002-G3/4	G 3/4"	16,7	19	47,6	65	22,3	76,0	52	42	50	10,50	M 10x30	3/8 x 1 1/2	0,31			
320	1"	WFG 3003-G1	G 1"	22,2	25	52,4	70	26,2	81,5	59	45	52	10,50	M 10x30	3/8 x 1 1/2	0,42			
280	1 1/4"	WFG 3004-G1 1/4	G 1 1/4"	28,6	24	58,7	79	30,2	94,5	73	50	60	*2	*3	7/16 x 1 1/2	0,67			
210	1 1/2"	WFG 3005-G1 1/2	G 1 1/2"	33,3	36	69,9	94	35,7	117,5	83	76	76	13,30	M 12x35	1/2 x 1 1/2	1,19			
210	2"	WFG 3006-G1 1/2	G 1 1/2"	33,3	45	77,8	102	42,9	128,5	97,0	108	80	13,30	M 12x35	1/2 x 1 1/2	-			
210	2"	WFG 3006-G2	G 2"	46,0	45	77,8	102	42,9	128,5	97,0	108	80	13,30	M 12x35	1/2 x 1 1/2	-			
Schraube Festigkeitskl.		Hochdruckreihe / High pressure													<i>metr.</i>	<i>unc.</i>			
10.9																			
420	1/2"	WFG 6001-G1/2	G 1/2"	11,0	12	40,5	56	18,2	64,0	48	39	40	8,50	M 8x30	5/16 x 1 1/4	0,18			
420	3/4"	WFG 6002-G3/4	G 3/4"	16,7	17	50,8	71	23,8	80,0	60	48	50	10,50	M 10x35	3/8 x 1 1/2	0,41			
420	1"	WFG 6003-G1	G 1"	22,2	24	57,2	81	27,8	94,0	70	60	59	*4		7/16 x 1 1/2	0,65			
420	1 1/4"	WFG 6004-G1 1/4	G 1 1/4"	28,6	31	66,6	95	31,8	104,0	78	68	65	*5	*6	1/2 x 1 3/4	0,81			
420	1 1/2"	WFG 6005-G1 1/2	G 1 1/2"	33,3	36	79,3	113	36,5	123,5	95	76	76	16,80	M 16x55	5/8 x 2	1,24			
420	2"	WFG 6006-G1 1/2	G 1 1/2"	33,3	45	96,8	133	44,5	137,0	114	108	80	21	M 20x70	3/4 x 2 1/2	-			
420	2"	WFG 6006-G2	G 2"	46,0	45	96,8	133	44,5	137,0	114	108	80	21	M 20x70	3/4 x 2 1/2	-			

*1 oder vergleichbare Güte / or comparable material

*2 wahlweise 10,5, 12,0 oder 12,75 / choice of 10.5, 12.0 or 12.75

*3 wahlweise M 10x30 oder M 12x35 / choice of M 10x30 or M 12x35

*4 wahlweise 12,0 oder 13,0 / choice of 12.0 or 13.0

*5 wahlweise 13,3 oder 14,75 / choice of 13.3 or 14.75

*6 wahlweise M 12x45 oder M 14x50

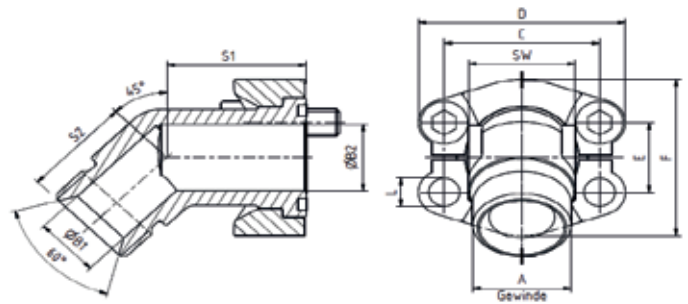

Bestellbezeichnung: ordering code:	S355J2^{*1}	1.4404^{*1}
• nur 45° Flansch-Adapter only 45° flange-adapter	WFG-...-45-G...	WFG-X-...-45-G...
• incl. Flanschhälften, Schraubensatz und O-Ring including split flanges, bolts and o-ring	WFG-...-45-G...M	WFG-X-...-45-G...MX

maximaler Betriebsdruck maximum recommended working pressure	S.A.E. Baugröße nominal flange size	Typ type	Abmessungen dimensions											Schrauben bolts	Gewicht weight		
			A	B1	B2	C	D	E	F	L	S1	S2	SW			M	kg
kg/cm ²	inch																
Schraube Festigkeitskl. 10.9	Standarddruckreihe / Standard pressure																
350	1/2"	WFG-3001-45-G012	G1/2"	11,1	12	38,1	54	17,5	46	8,5	39	32,5	24	M8x25	–		
350	3/4"	WFG-3002-45-G034	G3/4"	16,7	19	47,6	65	22,2	52	10,5	40,15	32,5	30	M10x30	–		
315	1"	WFG-3003-45-G100	G1"	22,2	25	52,4	70	26,2	59	10,5	47	37,35	36	M10x30	–		
250	1 1/4"	WFG-3004-45-G114	G1 1/4"	28,6	27	58,7	79	30,2	73	*2	51,8	40,4	41	*3	–		
200	1 1/2"	WFG-3005-45-G112	G1 1/2"	33,3	36	69,9	94	35,7	83	13,3	60,45	45,2	50	M12x35	–		
Schraube Festigkeitskl. 10.9	Hochdruckreihe / High pressure																
420	1/2"	WFG-6001-45-G012	G1/2"	11,1	12	40,5	56,4	18,2	47,8	8,5	39	32,5	24	M8x30	–		
420	3/4"	WFG-6002-45-G034	G3/4"	16,7	17	50,8	71	23,8	61	10,5	40,15	32,5	32	M10x35	–		
420	1"	WFG-6003-45-G100	G1"	22,2	24	57,2	81	27,8	70	13,3	47	37,35	41	M12x45	–		
420	1 1/4"	WFG-6004-45-G114	G1 1/4"	28,6	31	66,7	95	31,8	78	*4	51,8	40,4	46	*5	–		
420	1 1/2"	WFG-6005-45-G112	G1 1/2"	33,3	36	79,4	113	36,5	95	16,8	60,45	45,2	50	M16x55	–		

*1 oder vergleichbare Güte / or comparable material

*2 Schraubenbohrung 10,5; 12,0; 12,75 / bolt hole 10,75; 12,0; 12,75

*3 M10x30 oder M12x35

*4 Schraubenbohrung 14,6 oder 13,3

*5 M14x50 oder M12x45

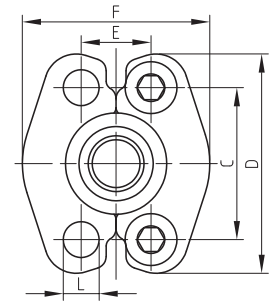
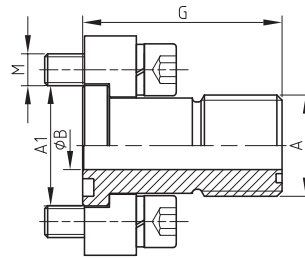

Bestellbezeichnung: ordering code:	S355J2^{*1} C22	1.4404^{*1} 316L
• nur Außengewindeflansch adaptor only	SORS-...	SORX-...
• incl. Flanschhälften, metrischem Schraubensatz und O-Ring including split flanges, metric bolts and o-ring	SORS-...M	SORX-...MX
• incl. Flanschhälften, UNC-Schraubensatz und O-Ring including split flanges, UNC bolts and o-ring	SORS-...U	SORX-...UX

maximaler Betriebsdruck maximum recommended working pressure	S.A.E. Baugröße nominal flange size	Typ type	Abmessungen dimensions										Schrauben bolts		Gewicht weight	
			A	A1	B	C	D	E	F	G	SW	L	M	kg		
kg/cm ²	inch															
Schraube Festigkeitskl.		Standarddruckreihe / Standard pressure														
10.9																
350	1/2"	SORS-3001-1-14	1"-14UN	30,2	12,3	38,1	54	17,5	46	48	24	8,50	M 8x25	5/16 x 1 1/4	-	
350	1/2"	SORS-3001-1 3/16-16	1 3/16"-16UN	30,2	9,6	38,1	54	17,5	46	48	24	8,50	M 8x25	5/16 x 1 1/4	-	
350	3/4"	SORS-3002-1 3/16-12	1 3/16"-12UN	38,1	15,5	47,6	65	22,3	52	53	30	10,50	M 10x30	3/8 x 1 1/4	-	
320	1"	SORS-3003-1 11/16-12	1 11/16"-12UN	44,5	26,0	52,4	70	26,2	59	54	36	10,50	M 10x30	3/8 x 1 1/4	-	
320	1"	SORS-3003-1 7/16-12	1 7/16"-12UN	44,5	20,6	52,4	70	26,2	59	54	36	10,50	M 10x30	3/8 x 1 1/4	-	
280	1 1/4"	SORS-3004-1 11/16-12	1 11/16"-12UN	50,8	26,0	58,7	79	30,2	73	58	42	*2	*3	7/16 x 1 1/2	-	
280	1 1/4"	SORS-3004-2-12	2"-12UN	50,8	32,0	58,7	79	30,2	73	58	42	*2	*3	7/16 x 1 1/2	-	
210	1 1/2"	SORS-3005-2-12	2"-12UN	60,3	32,0	69,9	94	35,7	83	60	46	13,30	M 12x35	1/2 x 1 1/2	-	
Schraube Festigkeitskl.		Hochdruckreihe / High pressure														
10.9																
420	1/2"	SORS-6001-1 3/16-16	1 3/16"-16UN	31,8	9,6	40,5	56	18,2	48	48	24	8,50	M 8x30	5/16 x 1 1/4	-	
420	1/2"	SORS-6001-1-14	1"-14UN	31,8	12,3	40,5	56	18,2	48	48	24	8,50	M 8x30	5/16 x 1 1/4	-	
420	3/4"	SORS-6002-1 3/16-12	1 3/16"-12UN	41,3	15,5	50,8	71	23,8	60	58	30	10,50	M 10x35	3/8 x 1 1/2	-	
420	1"	SORS-6003-1 7/16-12	1 7/16"-12UN	47,6	20,6	57,2	81	27,8	70	66	36	*4	M 12x45	7/16 x 1 1/4	-	
350	1"	SORS-6003-1 11/16-12	1 11/16"-12UN	47,6	26,0	57,2	81	27,8	70	66	36	*4	M 12x45	7/16 x 1 1/4	-	
350	1 1/4"	SORS-6004-1 11/16-12	1 11/16"-12UN	54,0	26,0	66,6	95	31,8	78	70	42	14,60	M 14x50	-	0,57	
350	1 1/4"	SORS-6004-1 11/16-12-M12	1 11/16"-12UN	54,0	26,0	66,6	95	31,8	78	70	42	13,30	M 12x45	1/2 x 1 3/4	0,57	
310	1 1/4"	SORS-6004-2-12	2"-12UN	54,0	32,0	66,6	95	31,8	78	70	42	14,60	M 14x50	-	0,50	
310	1 1/4"	SORS-6004-2-12-M12	2"-12UN	54,0	32,0	66,6	95	31,8	78	70	42	13,30	M 12x45	1/2 x 1 3/4	0,50	
310	1 1/2"	SORS-6005-2-12	2"-12UN	63,5	32,0	79,3	113	36,5	95	78	46	16,80	M 16x55	5/8 x 2	-	

Oberfläche: CR-6: auslaufend/Neu: CR-6 frei / surface: CR-6: phase-out/Neu: CR-6 free

*1 oder vergleichbare Güte / or comparable material

*2 wahlweise 10,5, 12,00 oder 12,75 / choice of 10.5, 12.00 or 12.75

*3 wahlweise M 10x30 oder M 12x35 / choice of M 10x30 or M 12x35

*4 wahlweise 12,0 oder 13,0 / choice of 12.0 or 13.0

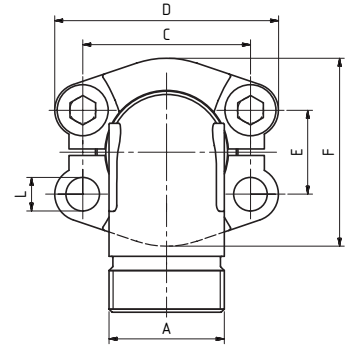
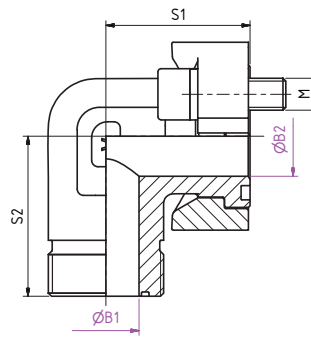

Bestellbezeichnung: ordering code:	S355J2^{*1}	1.4404^{*1}
• nur 90° Flansch-Adapter only 45° flange-adapter	WORS-...	WORX-...
• incl. Flanschhälften, Schraubensatz und O-Ring including split flanges (or complete flange), metric bolts and o-ring	WORS-...M	WORX-...MX
• incl. Flanschhälften, UNC-Schraubensatz, O-Ring including split flanges, unc-bolts, o-ring	WORS-...U	WORX-...UX

maximaler Betriebsdruck maximum recommended working pressure	S.A.E. Baugröße nominal flange size	Typ type	Abmessungen dimensions											Schrauben bolts		Gewicht weight
			A	B1	B2	C	D	E	F	L	S1	S2	SW	M	kg	
kg/cm ²	inch													metr.	unc.	
Schraube Festigkeitskl. 10.9			Standarddruckreihe / Standard pressure													
350	1/2"	WORS-3001-1 3/16	1 3/16"-16 UN	9,6	11	38,1	54	17,5	46	8,5	39	38	24	M 8x25	5/16 x 1 1/4	-
350		WORS-3001-1-14	1"-14 UNS	12,3	11	38,1	54	17,5	46	8,5	39	38	24	M 8x25	5/16 x 1 1/4	-
350	3/4"	WORS-3002-1 3/16	1 3/16"-12 UN	15,5	19	47,6	65	22,2	52	10,5	42	45	30	M10x30	3/8 x 1 1/4	-
320		WORS-3003-1 3/16	1 3/16"-12 UN	15,5	25	52,4	70	26,2	59	10,5	45	50	36	M10x30	3/8 x 1 1/4	-
320	1"	WORS-3003-1 7/16	1 7/16"-12 UN	20,6	25	52,4	70	26,2	59	10,5	45	50	36	M10x30	3/8 x 1 1/4	-
320		WORS-3003-1 1 1/16	1 1 1/16"-12 UN	26	25	52,4	70	26,2	59	10,5	45	50	36	M10x30	3/8 x 1 1/4	-
280	1 1/4"	WORS-3004-1 1 1/16	1 7/16"-12 UN	20,6	27	58,7	79	30,2	73	*2	50	59	41	*3	7/16 x 1 1/2	-
280		WORS-3004-1 1 1/16	1 1 1/16"-12 UN	26	27	58,7	79	30,2	73	*2	50	59	41	*3	7/16 x 1 1/2	-
280		WORS-3004-2-12	2"-12 UN	32	27	58,7	79	30,2	73	*2	50	59	41	*3	7/16 x 1 1/2	-
210	1 1/2"	WORS-3005-1 1 1/16	1 1 1/16"-12 UN	26	36	69,9	94	35,7	83	13,3	55	64	50	M12x35	1/2 x 1 1/2	-
210		WORS-3005-2-12	2"-12 UN	32	36	69,9	94	35,7	83	13,3	55	64	50	M12x35	1/2 x 1 1/2	-
210	2"	WORS-3006-2-12	2"-12 UN	32	45	77,8	101,6	42,9	97	13,3	108	80	60	M12x35	4 1 1/2	-
Schraube Festigkeitskl. 10.9			Hochdruckreihe / High pressure													
420	1/2"	WORS-6001-1 3/16	1 3/16"-16 UN	9,6	12	40,5	56,4	18,2	47,8	8,5	39	38	24	M 8x30	5/16 x 1 1/4	-
420		WORS-6001-1-14	1"-14 UNS	12,3	12	40,5	56,4	18,2	47,8	8,5	39	38	24	M8x30	5/16 x 1 1/4	-
420	3/4"	WORS-6002-1-14	1"-14 UNS	12,3	17	50,8	71	23,8	61	10,5	48	48	32	M10x35	3/8 x 1 1/2	-
420		WORS-6002-1 3/16	1 3/16"-12 UN	15,5	17	50,8	71	23,8	61	10,5	48	48	32	M10x35	3/8 x 1 1/2	-
420	1"	WORS-6003-1 3/16	1 3/16"-12 UN	20,6	24	57,2	81	27,8	70	*4	60	55	41	M12x45	7/16 x 1 3/4	-
420		WORS-6003-1 1 1/16	1 1 1/16"-12 UN	26	24	57,2	81	27,8	70	*4	60	55	41	M12x45	7/16 x 1 3/4	-
350	1 1/4"	WORS-6004-1 7/16	1 7/16"-12 UN	20,6	31	66,7	95	31,8	78	*5	68	65	46	*6	1/2 x 1 3/4	-
350		WORS-6004-1 1 1/16	1 1 1/16"-12 UN	26	31	66,7	95	31,8	78	*5	68	65	46	*6	1/2 x 1 3/4	-
350		WORS-6004-2-12	2"-12 UN	32	31	66,7	95	31,8	78	*5	68	65	46	*6	1/2 x 1 3/4	-
310	1 1/2"	WORS-6005-1 1 1/16	1 1 1/16"-12 UN	26	36	79,4	113	36,5	95	16,8	76	72	50	M16x55	5/8 x 2	-
310		WORS-6005-2-12	2"-12 UN	32	36	79,4	113	36,5	95	16,8	76	72	50	M16x55	5/8 x 2	-
310	2"	WORS-6006-2-12	2"-12 UN	32	45	96,8	133	44,5	114	21	108	80	60	M20x70	3/4 x 2 1/2	-

*1 oder vergleichbare Güte / or comparable material

*2 Schraubenbohrung 10,5; 12,0; 12,75 / bolt hole 10,75; 12,0; 12,75

*3 M10x30 oder M12x35

*4 Schraubenbohrung 13,3 oder 12,0

*5 Schraubenbohrung 14,6 oder 13,3

*6 M14x50 oder M12x45

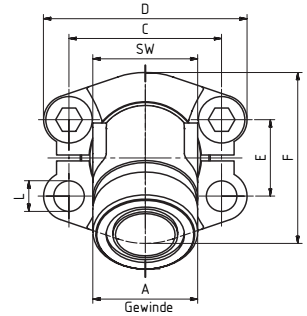
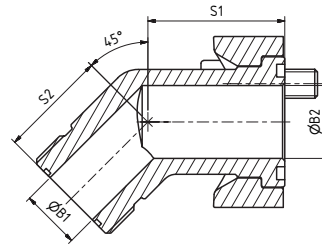

Bestellbezeichnung: ordering code:	S355J2^{*1}	1.4404^{*1}
• nur 90° Flansch-Adapter only 45° flange-adapter	WORS-...-45-...(UN)	WORX-...-45-...(UN)
• incl. Flanschhälften, Schraubensatz und O-Ring including split flanges, bolts and o-ring	WORS-...-45-...(UN)M	WORX-...-45-...(UN)MX
• incl. Flanschhälften, UNC-Schraubensatz, O-Ring including split flanges, unc-bolts, o-ring	WORS-...-45-...(UN)U	WORX-...-45-...(UN)UX

maximaler Betriebsdruck maximum recommended working pressure	S.A.E. Baugröße nominal flange size	Typ type	Abmessungen dimensions											Schrauben bolts		Gewicht weight			
			A	B1	B2	C	D	E	F	L	S1	S2	SW	M	kg				
kg/cm ²	inch																metr.	unc.	
Schraube Festigkeitskl.		Standarddruckreihe / Standard pressure																	
10.9																			
350	1/2"	WORS-3001-45-1 3/16	1 3/16"-16 UN	9,6	11	38,1	54	17,5	46	8,5	39	32,5	24	M 8x25	5/16 x 1 1/4	-			
350		WORS-3001-45-1-14	1"-14 UNS	12,3	11	38,1	54	17,5	46	8,5	39	32,5	24	M 8x25	5/16 x 1 1/4	-			
350	3/4"	WORS-3002-45-1 3/16	1 3/16"-12 UN	15,5	19	47,6	65	22,2	52	10,5	40,15	32,5	30	M10x30	3/8 x 1 1/4	-			
320	1"	WORS-3003-45-1 3/16	1 3/16"-12 UN	15,5	25	52,4	70	26,2	59	10,5	47	37,35	36	M10x30	3/8 x 1 1/4	-			
320		WORS-3003-45-1 7/16	7/16"-12 UN	20,6	25	52,4	70	26,2	59	10,5	47	37,35	36	M10x30	3/8 x 1 1/4	-			
320		WORS-3003-45-1 1 1/16	1 1/16"-12 UN	26	25	52,4	70	26,2	59	10,5	47	37,35	36	M10x30	3/8 x 1 1/4	-			
280	1 1/4"	WORS-3004-45-1 7/16	1 7/16"-12 UN	20,6	27	58,7	79	30,2	73	*2	51,8	40,4	41	*3	7/16 x 1 1/2	-			
280		WORS-3004-45-1 1 1/16	1 1/16"-12 UN	20,6	27	58,7	79	30,2	73	*2	51,8	40,4	41	*3	7/16 x 1 1/2	-			
280		WORS-3004-45-2-12	2"-12 UN	32	27	58,7	79	30,2	73	*2	51,8	40,4	41	*3	7/16 x 1 1/2	-			
210	1 1/2"	WORS-3005-45-1 1 1/16	1 1/16"-12 UN	26	36	69,9	94	35,7	83	13,3	60,45	45,2	50	M12x35	1/2 x 1 1/2	-			
210		WORS-3005-45-2-12	2"-12 UN	32	36	69,9	94	35,7	83	13,3	60,45	45,2	50	M12x35	1/2 x 1 1/2	-			
Schraube Festigkeitskl.		Hochdruckreihe / High pressure																	
10.9																			
420	1/2"	WORS-6001-45-1 3/16	1 3/16"-16UN	9,6	12	40,5	56,4	18,2	47,8	8,5	39	32,5	24	M8x30	5/16 x 1 1/4	-			
420		WORS-6001-45-1-14	1"-14 UNS	12,3	12	40,5	56,4	18,2	47,8	8,5	39	32,5	24	M8x30	5/16 x 1 1/4	-			
420	3/4"	WORS-6002-45-1-14	1"-14 UNS	12,3	17	50,8	71	23,8	61	10,5	40,15	32,5	32	M10x35	3/8 x 1 1/2	-			
420		WORS-6002-45-1 3/16	1 3/16"-12 UN	15,5	17	50,8	71	23,8	61	10,5	40,15	32,5	32	M10x35	3/8 x 1 1/2	-			
420	1"	WORS-6003-45-1 7/16	1 7/16"-12 UN	20,6	24	57,2	81	27,8	70	*4	47	37,35	41	M12x45	7/16 x 1 3/4	-			
420		WORS-6003-45-1 1 1/16	1 1/16"-12 UN	26	24	57,2	81	27,8	70	*4	47	37,35	41	M12x45	7/16 x 1 3/4	-			
350	1 1/4"	WORS-6004-45-1 7/16	1 7/16"-12 UN	20,6	31	66,7	95	31,8	78	*5	51,8	40,4	46	*6	1/2 x 1 3/4	-			
350		WORS-6004-45-1 1 1/16	1 1/16"-12 UN	26	31	66,7	95	31,8	78	*5	51,8	40,4	46	*6	1/2 x 1 3/4	-			
350		WORS-6004-45-2-12	2"-12 UN	32	31	66,7	95	31,8	78	*5	51,8	40,4	46	*6	1/2 x 1 3/4	-			
310	1 1/2"	WORS-6005-45-1 1 1/16	1 1/16"-12 UN	26	36	79,4	113	36,5	95	16,8	60,45	45,2	50	M16x55	5/8 x 2	-			
310		WORS-6005-45-2-12	2"-12 UN	32	36	79,4	113	36,5	95	16,8	60,45	45,2	50	M16x55	5/8 x 2	-			

*1 oder vergleichbare Güte / or comparable material

*2 Schraubenbohrung 10,5; 12,0; 12,75 / bolt hole 10,75; 12,0; 12,75

*3 M10x30 oder M12x35

*4 Schraubenbohrung 13,3 oder 12,0

*5 Schraubenbohrung 14,6 oder 13,3

*6 M14x50 oder M12x45



BL-...

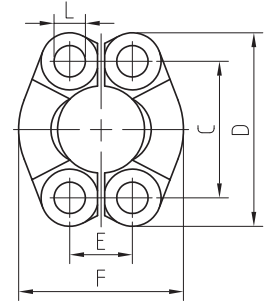
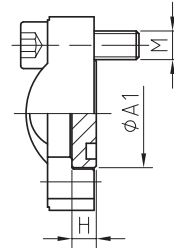

BLO-...

ohne Nut

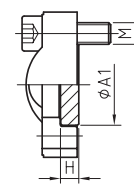

Bestellbezeichnung: ordering code:	S355J2^{*1}	1.4404^{*1} 316L
• nur Blindstopfen flange plug only	BL-...	BL-X-...
• incl. Flanschhälften (oder Vollflansch), metrischem Schraubensatz und O-Ring including split flanges (or complete flange), metric bolts and o-ring	BL-...FH-M	BL-X-...FH-MX
• incl. Flanschhälften (oder Vollflansch), UNC-Schraubensatz und O-Ring including split flanges (or complete flange), UNC bolts and o-ring	BL-...FH-U	BL-X-...FH-UX
• Blindstopfen ohne Nut Plug without groove	BLO-...	

maximaler Betriebsdruck maximum recommended working pressure	S.A.E. Baugröße nominal flange size	Typ type	Abmessungen dimensions							Schrauben bolts		Gewicht (nur Teller) weight (plug only)	
			A1	C	D	E	F	H	L	M	kg		
kg/cm ²	inch											kg	
Schraube Festigkeitskl. 10.9	Standarddruckreihe / Standard pressure										metr.	unc.	
210	1/2"	BL/BLO 3001	30,2	38,1	54	17,5	46	6,8	8,50	M 8x25	5/16 x 1 1/4	0,03	
210	3/4"	BL/BLO 3002	38,1	47,6	65	22,3	52	6,8	10,50	M 10x30	3/8 x 1 1/4	0,05	
210	1"	BL/BLO 3003	44,5	52,4	70	26,2	59	8,0	10,50	M 10x30	3/8 x 1 1/4	0,09	
210	1 1/4"	BL/BLO 3004	50,8	58,7	79	30,2	73	8,0	*2	*3	7/16 x 1 1/2	0,12	
160	1 1/2"	BL/BLO 3005	60,3	69,9	94	35,7	83	8,0	13,30	M 12x35	1/2 x 1 1/2	0,17	
210	2"	BL/BLO 3006	71,4	77,8	102	42,9	97	9,6	13,30	M 12x35	1/2 x 1 1/2	0,29	
-	2 1/2"	BL/BLO 3007	84,1	88,9	114	50,8	109	9,6	13,30	M 12x35	1/2 x 1 1/2	0,39	
-	3"	BL/BLO 3008	101,6	106,4	135	61,9	131	9,6	17,00	M 16x50	5/8 x 2	0,58	
-	3 1/2"	BL/BLO 3009	114,3	120,7	152	69,9	140	11,3	17,00	M 16x50	5/8 x 2	0,86	
-	4"	BL/BLO 3010	127,0	130,2	162	77,8	152	11,3	17,00	M 16x50	5/8 x 2	1,02	
-	5"	BL/BLO 3011	152,4	152,4	185	92,1	181	11,3	17,00	M 16x55	5/8 x 2	1,96	
Schraube Festigkeitskl. 10.9	Hochdruckreihe / High pressure										metr.	unc.	
250	1/2"	BL/BLO 6001	31,8	40,5	56	18,2	48	7,8	8,50	M 8x30	5/16 x 1 1/4	0,04	
250	3/4"	BL/BLO 6002	41,3	50,8	71	23,8	60	8,8	10,50	M 10x35	3/8 x 1 1/2	0,09	
250	1"	BL/BLO 6003	47,6	57,2	81	27,8	70	9,5	*4	M 12x45	7/16 x 1 3/4	0,13	
250	1 1/4"	BL/BLO 6004	54,0	66,6	95	31,8	78	10,3	*5	*6	1/2 x 1 3/4	0,18	
250	1 1/2"	BL/BLO 6005	63,5	79,3	113	36,5	95	12,6	16,80	M 16x55	5/8 x 2	0,30	
250	2"	BL/BLO 6006	79,4	96,8	133	44,5	114	12,6	21,00	M 20x70	3/4 x 2 1/2	0,48	
-	2 1/2"	BL/BLO 6007	108,0	123,8	180	58,8	152	21,2	26,00	M 24x80	-	1,26	
-	3"	BL/BLO 6008	132,0	152,4	215	71,6	198	26,5	32,00	M 30x90	-	2,31	

*1 oder vergleichbare Güte / or comparable material

*2 wahlweise 10,5, 12,00 oder 12,75 / choice of 10.5, 12.00 or 12.75

*3 wahlweise M 10x30 oder M 12x35 / choice of M 10x30 or M 12x35

*4 wahlweise 12,0 oder 13,0 / choice of 12.0 or 13.0

*5 wahlweise 13,3 oder 14,6 / choice of 13.3 or 14.6

*6 wahlweise M 12x45 oder M 14x50

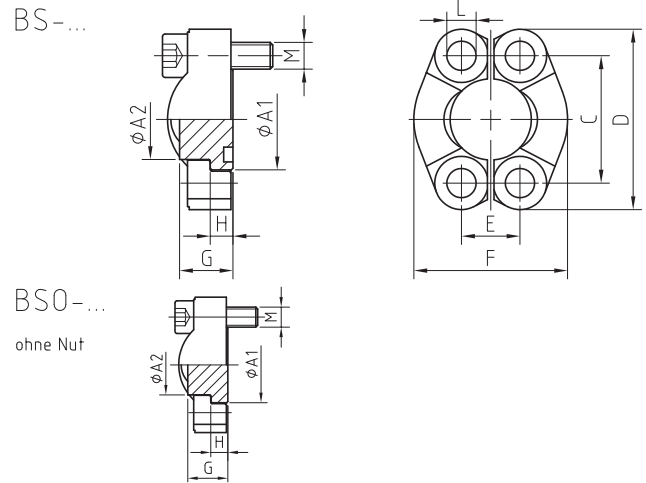
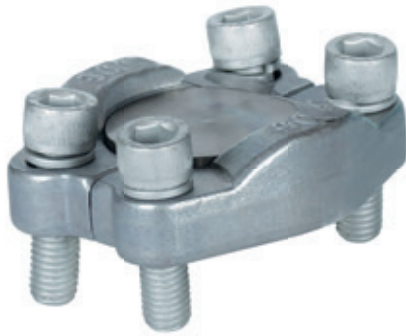

Bestellbezeichnung: ordering code:	S355J2^{*1}	1.4404^{*1} 316L
• nur Blindstopfen flange plug only	BS-...	BS-X-...
• incl. Flanschhälften (oder Vollflansch), metrischem Schraubensatz und O-Ring including split flanges (or complete flange), metric bolts and O-ring	BS-...-M	BS-X-...-MX
• incl. Flanschhälften (oder Vollflansch), UNC-Schraubensatz und O-Ring including split flanges (or complete flange), UNC bolts and O-ring	BS-...-U	BS-X-...-UX
• Blindstopfen ohne Nut Plug without groove	BSO-...	

maximaler Betriebsdruck maximum recommended working pressure	S.A.E. Baugröße nominal flange size	Typ type	Abmessungen dimensions										Schrauben bolts		Gewicht (nur Teller) weight (plug only)	
			A1	A2	C	D	E	F	G	H	L	M		kg		
kg/cm ²	inch															
Schraube Festigkeitskl. 10.9		Standarddruckreihe / Standard pressure											metr.	unc.		
350	1/2"	BS/BSO 3001	30,2	24,0	38,1	54	17,5	46	16	6,8	8,50	M 8x25	5/16 x 1 1/4	0,07		
350	3/4"	BS/BSO 3002	38,1	31,8	47,6	65	22,3	52	17	6,8	10,50	M 10x30	3/8 x 1 1/4	0,12		
320	1"	BS/BSO 3003	44,5	38,0	52,4	70	26,2	59	17	8,0	10,50	M 10x30	3/8 x 1 1/4	0,17		
280	1 1/4"	BS/BSO 3004	50,8	43,0	58,7	79	30,2	73	17	8,0	*2	*3	7/16 x 1 1/2	0,22		
210	1 1/2"	BS/BSO 3005	60,3	50,0	69,9	94	35,7	83	19	8,0	13,30	M 12x35	1/2 x 1 1/2	0,34		
210	2"	BS/BSO 3006	71,4	62,0	77,8	102	42,9	97	19	9,6	13,30	M 12x35	1/2 x 1 1/2	0,51		
175	2 1/2"	BS/BSO 3007	84,1	74,0	88,9	114	50,8	109	40	9,6	13,30	M 12x35	1/2 x 1 1/2	1,43		
160	3"	BS/BSO 3008	101,6	90,0	106,4	135	61,9	131	45	9,6	17,00	M 16x50	5/8 x 2	2,35		
35	3 1/2"	BS/BSO 3009	114,3	102,0	120,7	152	69,9	140	30	11,3	17,00	M 16x50	5/8 x 2	2,80		
35	4"	BS/BSO 3010	127,0	114,5	130,2	162	77,8	152	36	11,3	17,00	M 16x50	5/8 x 2	3,08		
35	5"	BS/BSO 3011	152,4	140,0	152,4	185	92,1	181	45	11,3	17,00	M 16x55	5/8 x 2	5,69		
Schraube Festigkeitskl. 10.9		Hochdruckreihe / High pressure											metr.	unc.		
420	1/2"	BS/BSO 6001	31,8	24,0	40,5	56	18,2	48	14	7,8	8,50	M 8x30	5/16 x 1 1/4	0,07		
420	3/4"	BS/BSO 6002	41,3	31,8	50,8	71	23,8	60	15	8,8	10,50	M 10x35	3/8 x 1 1/2	0,13		
420	1"	BS/BSO 6003	47,6	38,0	57,2	81	27,8	70	16	9,5	*4	*6	7/16 x 1 3/4	0,18		
420	1 1/4"	BS/BSO 6004	54,0	44,0	66,6	95	31,8	78	16	10,3	*5	*6	1/2 x 1 3/4	0,38		
420	1 1/2"	BS/BSO 6005	63,5	50,8	79,3	113	36,5	95	19	12,6	16,80	M 16x55	5/8 x 2	0,41		
420	2"	BS/BSO 6006	79,4	67,0	96,8	133	44,5	114	30	12,6	21,00	M 20x70	3/4 x 2 1/2	0,95		
420	2 1/2"	BS/BSO 6007	108,0	89,0	123,8	180	58,8	152	45	21,2	26,00	M 24x80	-	2,66		
420	3"	BS/BSO 6008	132,0	114,3	152,4	215	71,6	198	55	26,5	32,00	M 30x90	-	5,10		

*1 oder vergleichbare Güte / or comparable material

*2 wahlweise 10,5, 12,00 oder 12,75 / choice of 10.5, 12.00 or 12.75

*3 wahlweise M 10x30 oder M 12x35 / choice of M 10x30 or M 12x35

*4 wahlweise 12,0 oder 13,0 / choice of 12.0 or 13.0

*5 wahlweise 13,3 oder 14,6 / choice of 13.3 or 14.6

*6 wahlweise M 12x45 oder M 14x50

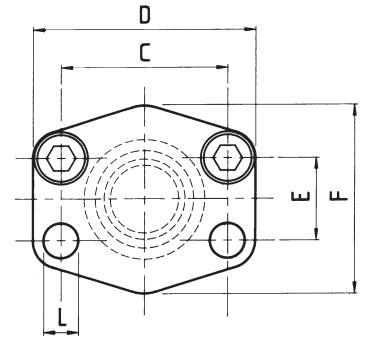
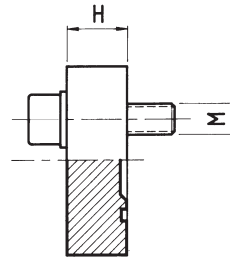

Bestellbezeichnung: ordering code:	S355J2^{*1}	1.4404^{*1} 316L
• nur Flansch flange only	AFC-...	AFC-X-...
• incl. metrischem Schraubensatz und O-Ring including metric bolts and o-ring	AFC-...M	AFC-X-...MX
• incl. UNC-Schraubensatz und O-Ring including UNC bolts and o-ring	AFC-...U	AFC-X-...UX

maximaler Betriebsdruck maximum recommended working pressure	S.A.E. Baugröße nominal flange size	Typ type	Abmessungen dimensions							Schrauben bolts		Gewicht weight
			C	D	E	F	H	L	M	kg		
kg/cm ²	inch											
Schraube Festigkeitskl. 10.9			Standarddruckreihe / Standard pressure							<i>metr.</i>	<i>unc.</i>	
350	1/2"	AFC 080	38,1	56	17,5	48	16	9,0	M 8x30	5/16 x 1 1/4	0,20	
350	3/4"	AFC 100	47,6	65	22,3	50	16	11,0	M 10x35	3/8 x 1 1/2	0,30	
320	1"	AFC 102	52,4	70	26,2	60	19	11,0	M 10x35	3/8 x 1 1/2	0,37	
280	1 1/4"	AFC 104	58,7	79	30,2	68	18	11,5	M 10x40	7/16 x 1 1/2	0,54	
210	1 1/2"	AFC 106	69,9	93	35,7	78	20	13,5	M 12x45	1/2 x 1 3/4	0,90	
210	2"	AFC 108	77,8	102	42,9	90	20	13,5	M 12x45	1/2 x 1 3/4	1,00	
175	2 1/2"	AFC 110	88,9	114	50,8	105	20	13,5	M 12x45	1/2 x 1 3/4	1,35	
160	3"	AFC 112	106,4	134	61,9	124	24	17,5	M 16x50	5/8 x 2	2,35	
35	3 1/2"	AFC 114	120,7	152	69,9	136	22	17,5	M 16x50	5/8 x 2	2,90	
35	4"	AFC 116	130,2	162	77,8	146	25	17,5	M 16x50	5/8 x 2	3,90	
35	5"	AFC 118	152,4	190	92,1	170	28	17,5	M 16x55	5/8 x 2	4,00	
Schraube Festigkeitskl. 10.9			Hochdruckreihe / High pressure							<i>metr.</i>	<i>unc.</i>	
420	1/2"	AFC 401	40,5	56	18,2	48	16	9,0	M 8x30	5/16 x 1 1/4	0,20	
420	3/4"	AFC 402	50,8	71	23,8	60	19	11,0	M 10x35	3/8 x 1 1/2	0,48	
420	1"	AFC 403	57,2	81	27,8	70	24	13,0	M 12x45	7/16 x 1 3/4	0,77	
420	1 1/4"	AFC 404	66,6	95	31,8	78	27	15,0 ^{*2}	M 14x50	–	1,15	
420	1 1/4"	AFC 404 L=13,5	66,6	95	31,8	78	27	13,5	M 12x45	1/2 x 1 3/4	1,20	
420	1 1/2"	AFC 405	79,3	112	36,5	94	30	17,0	M 16x50	5/8 x 2	1,80	
420	2"	AFC 406	96,8	134	44,5	114	28	21,0	M 20x65	3/4 x 2 1/2	2,00	
420	2 1/2"	AFC 407	123,8	180	58,8	150	45	26,0	M 24x80	–	5,30	
420	3"	AFC 408	152,4	208	71,6	178	55	32,0	M 30x90	–	12,07	

*1 oder vergleichbare Güte / or comparable material

*2 L=13,5 für UNC-Schrauben / L=13.5 with UNC-bolts

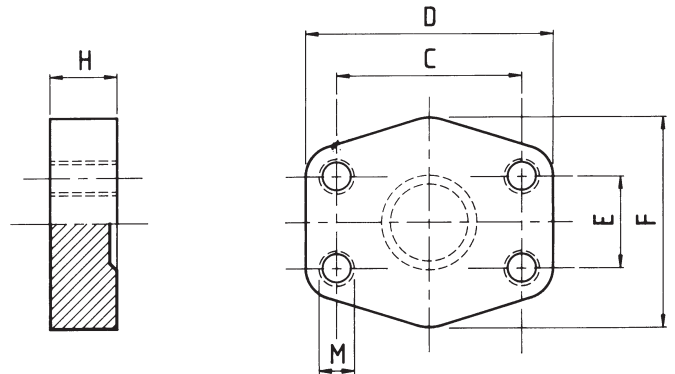

Bestellbezeichnung: ordering code:	S355J2^{*1}	1.4404^{*1} 316L
• nur Flansch flange only	GFC-...	GFC-X-...

maximaler Betriebsdruck maximum recommended working pressure	S.A.E. Baugröße nominal flange size	Typ type	Abmessungen dimensions					Gewinde thread	Gewicht weight
			C	D	E	F	H		
kg/cm ²	inch								
Schraube Festigkeitskl. 10.9			Standarddruckreihe / Standard pressure						
350	1/2"	GFC 080	38,1	56	17,5	48	16	M 8	0,20
350	3/4"	GFC 100	47,6	65	22,3	50	16	M 10	0,30
320	1"	GFC 102	52,4	70	26,2	60	19	M 10	0,37
280	1 1/4"	GFC 104	58,7	79	30,2	68	18	M 10	0,54
210	1 1/2"	GFC 106	69,9	93	35,7	78	20	M 12	0,90
210	2"	GFC 108	77,8	102	42,9	90	20	M 12	1,00
175	2 1/2"	GFC 110	88,9	114	50,8	105	20	M 12	1,35
160	3"	GFC 112	106,4	134	61,9	124	24	M 16	2,35
35	3 1/2"	GFC 114	120,7	152	69,9	136	22	M 16	2,90
35	4"	GFC 116	130,2	162	77,8	146	25	M 16	3,90
35	5"	GFC 118	152,4	190	92,1	170	28	M 16	4,00
Schraube Festigkeitskl. 10.9			Hochdruckreihe / High pressure						
420	1/2"	GFC 401	40,5	56	18,2	48	16	M 8	0,20
420	3/4"	GFC 402	50,8	71	23,8	60	19	M 10	0,48
420	1"	GFC 403	57,2	81	27,8	70	24	M 12	0,77
420	1 1/4"	GFC 404	66,6	95	31,8	78	27	M 14	1,15
420	1 1/4"	GFC 404 - M12	66,6	95	31,8	78	27	M 12	1,24
420	1 1/2"	GFC 405	79,3	112	36,5	94	30	M 16	1,80
420	2"	GFC 406	96,8	134	44,5	114	28	M 20	2,00
420	2 1/2"	GFC 407	123,8	180	58,8	150	45	M 24	5,30

*1 oder vergleichbare Güte / or comparable material

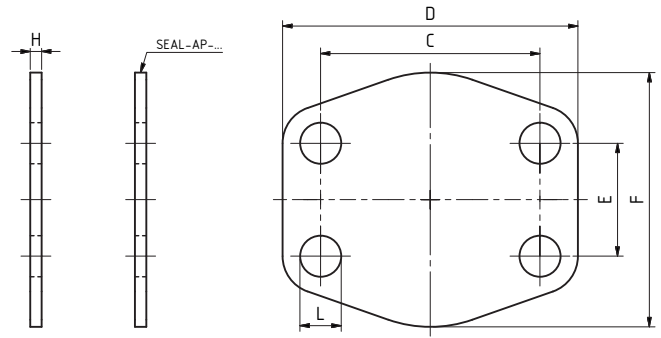

Bestellbezeichnung: ordering code:	St 35
• nur Abschlussplatte locking sheet only	AP-...
• Flachdichtung Buna 70 Shore flat seal	SEAL-AP-...

maximaler Betriebsdruck maximum recommended working pressure	S.A.E. Baugröße nominal flange size	Typ type	Abmessungen dimensions						Gewicht weight	
			C	D	E	F	H	L		Flachdichtung
kg/cm ²	inch								kg	
Schraube Festigkeitskl. 10.9		Standarddruckreihe / Standard pressure								
–	1/2"	AP-080	38,1	54	17,5	45,6	3	9	SEAL-AP-080	0,04
–	3/4"	AP-100	47,6	65	22,3	52,0	3	11	SEAL-AP-100	0,06
–	1"	AP-102	52,4	70	26,2	60,0	3	11	SEAL-AP-102	0,08
–	1 1/4"	AP-104	58,7	79	30,2	68,0	3	11	SEAL-AP-104	0,09
–	1 1/2"	AP-106	69,9	94	35,7	83,0	3	13	SEAL-AP-106	0,14
–	2"	AP-108	77,8	102	42,9	90,0	3	13	SEAL-AP-108	0,17
–	2 1/2"	AP-110	88,9	114	50,8	108,0	3	13	SEAL-AP-110	0,23
–	3"	AP-112	106,4	134	61,9	130,0	4	17	SEAL-AP-112	0,43
–	3 1/2"	AP-114	120,7	152	69,9	139,0	4	17	SEAL-AP-114	0,54
–	4"	AP-116	130,2	162	77,8	152,0	4	17	SEAL-AP-116	0,65
–	5"	AP-118	152,4	184	92,1	180,0	4	17	SEAL-AP-118	0,86
Schraube Festigkeitskl. 10.9		Hochdruckreihe / High pressure								
–	1/2"	AP-401	40,5	56	18,2	47,2	4	9	SEAL-AP-401	0,06
–	3/4"	AP-402	50,8	71	23,8	60,0	4	11	SEAL-AP-402	0,10
–	1"	AP-403	57,2	81	27,8	70,0	4	13	SEAL-AP-403	0,13
–	1 1/4"	AP-404	66,6	95	31,8	78,0	4	15	SEAL-AP-404	0,17
–	1 1/2"	AP-405	79,3	112	36,5	94,0	4	17	SEAL-AP-405	0,24
–	2"	AP-406	96,8	133	44,5	114,0	4	21	SEAL-AP-406	0,35
–	2 1/2"	AP-407	123,8	180	58,8	152,0	4	26	SEAL-AP-407	0,65
–	3"	AP-408	152,4	215	71,6	198,0	4	32	SEAL-AP-408	0,90

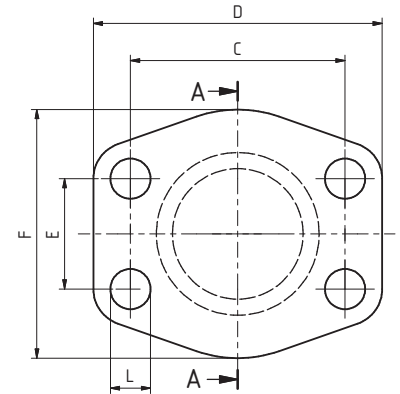
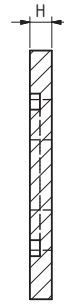

Bestellbezeichnung: ordering code:	S235JRG2 C45
• nur Abschlussplatte mit O-Ringnut locking sheet with o-ring groove only	APO-...

maximaler Betriebsdruck maximum recommended working pressure	S.A.E. Baugröße nominal flange size	Typ type	Abmessungen dimensions						Gewicht weight	
			C	D	E	F	H	L		
kg/cm ²	inch								kg	
Schraube Festigkeitskl. 10.9			Standarddruckreihe / Standard pressure							
–	1/2"	APO-080	38,1	54	17,5	45,6	6	9	0,078	
–	3/4"	APO-100	47,6	65	22,3	50,0	6	11	0,106	
–	1"	APO-102	52,4	70	26,2	60,0	6	11	0,138	
–	1 1/4"	APO-104	58,7	79	30,2	68,0	6	11	0,183	
–	1 1/2"	APO-106	69,9	94	35,7	82,0	6	13	0,265	
–	2"	APO-108	77,8	102	42,9	76,0	6	13	0,302	
–	2 1/2"	APO-110	88,9	114	50,8	108,0	6	13	0,443	
–	3"	APO-112	106,4	134	61,9	130,0	6	17	0,622	
–	3 1/2"	APO-114	120,7	152	69,9	139,0	6	17	0,776	
–	4"	APO-116	130,2	162	77,8	152,0	6	17	0,912	
–	5"	APO-118	152,4	184	92,1	180,0	6	17	1,238	
Schraube Festigkeitskl. 10.9			Hochdruckreihe / High pressure							
–	1/2"	APO-401	40,5	56	18,2	47,2	6	9	0,085	
–	3/4"	APO-402	50,8	71	23,8	60,0	6	11	0,141	
–	1"	APO-403	57,2	81	27,8	70,0	6	13	0,187	
–	1 1/4"	APO-404	66,6	95	31,8	78,0	6	15	0,249	
–	1 1/2"	APO-405	79,3	112	36,5	94,0	6	17	0,357	
–	2"	APO-406	96,8	133	44,5	114,0	6	21	0,510	
–	2 1/2"	APO-407	123,8	180	58,8	152,0	6	26	0,948	
–	3"	APO-408	152,4	208	71,6	178,0	6	33	1,270	

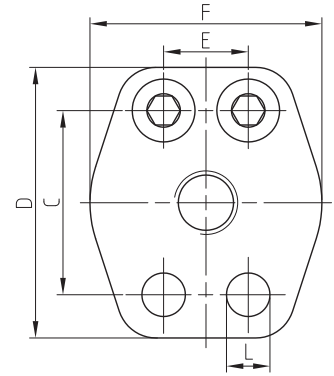
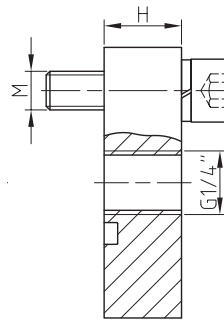

Bestellbezeichnung: ordering code:	S355J2^{*1}	1.4404^{*1} 316L
• nur Flansch flange only	AFC-...G1/4"	AFC-X-...G1/4"
• incl. metrischem Schraubensatz und O-Ring including metric bolts and o-ring	AFC-...G1/4"M	AFC-X-...G1/4"MX
• incl. UNC-Schraubensatz und O-Ring including UNC bolts and o-ring	AFC-...G1/4"U	AFC-X-...G1/4"UX

maximaler Betriebsdruck maximum recommended working pressure	S.A.E. Baugröße nominal flange size	Typ type	Abmessungen dimensions						Schrauben bolts		Gewicht weight	
			C	D	E	F	H	L	M	kg		
kg/cm ²	inch											
Schraube Festigkeitskl. 10.9	Standarddruckreihe / Standard pressure									metr.	unc.	
350	1/2"	AFC 080 G1/4"	38,1	56	17,5	48	16	9,0	M 8x30	5/16 x 1 1/4	0,20	
350	3/4"	AFC 100 G1/4"	47,6	65	22,3	50	16	11,0	M 10x35	3/8 x 1 1/2	0,30	
320	1"	AFC 102 G1/4"	52,4	70	26,2	60	19	11,0	M 10x35	3/8 x 1 1/2	0,37	
280	1 1/4"	AFC 104 G1/4"	58,7	79	30,2	68	18	11,5	M 10x40	7/16 x 1 1/2	0,54	
210	1 1/2"	AFC 106 G1/4"	69,9	93	35,7	78	20	13,5	M 12x45	1/2 x 1 3/4	0,90	
210	2"	AFC 108 G1/4"	77,8	102	42,9	90	20	13,5	M 12x45	1/2 x 1 3/4	1,00	
175	2 1/2"	AFC 110 G1/4"	88,9	114	50,8	105	20	13,5	M 12x45	1/2 x 1 3/4	1,35	
160	3"	AFC 112 G1/4"	106,4	134	61,9	124	24	17,5	M 16x50	5/8 x 2	2,35	
35	3 1/2"	AFC 114 G1/4"	120,7	152	69,9	136	22	17,5	M 16x50	5/8 x 2	2,90	
35	4"	AFC 116 G1/4"	130,2	162	77,8	146	25	17,5	M 16x50	5/8 x 2	3,90	
35	5"	AFC 118 G1/4"	152,4	190	92,1	170	28	17,5	M 16x55	5/8 x 2	4,00	
Schraube Festigkeitskl. 10.9	Hochdruckreihe / High pressure									metr.	unc.	
420	1/2"	AFC 401 G1/4"	40,5	56	18,2	48	16	9,0	M 8x30	5/16 x 1 1/4	0,20	
420	3/4"	AFC 402 G1/4"	50,8	71	23,8	60	19	11,0	M 10x35	3/8 x 1 1/2	0,48	
420	1"	AFC 403 G1/4"	57,2	81	27,8	70	24	13,0	M 12x45	7/16 x 1 1/2	0,77	
420	1 1/4"	AFC 404 G1/4"	66,6	95	31,8	78	27	15,0 ^{*2}	M 14x50	1/2 x 1 3/4	0,85	
420	1 1/2"	AFC 405 G1/4"	79,3	112	36,5	94	30	17,0	M 16x50	5/8 x 2	1,80	
420	2"	AFC 406 G1/4"	96,8	134	44,5	114	28	21,0	M 20x65	3/4 x 2 1/2	2,00	
420	2 1/2"	AFC 407 G1/4"	123,8	180	58,8	150	45	26,0	M 24x80	–	5,30	

*1 oder vergleichbare Güte / or comparable material

*2 L=13,5 für UNC-Schrauben / L=13.5 with UNC-bolts

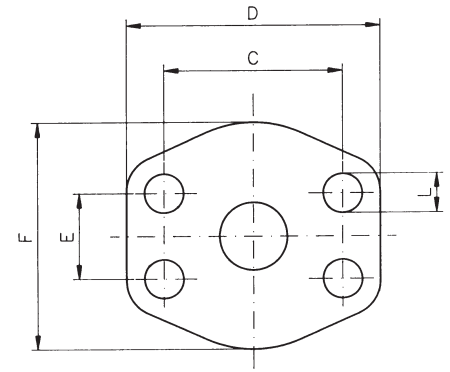
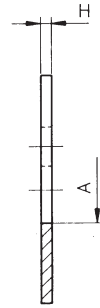

Bestellbezeichnung: ordering code:	ST 35
• nur Zwischenplatte adaptor sheet only	ZP-...

maximaler Betriebsdruck maximum recommended working pressure	S.A.E. Baugröße nominal flange size	Typ type	Abmessungen dimensions							Gewicht weight
			A	C	D	E	F	H	L	
kg/cm ²	inch									kg
Schraube Festigkeitskl.			Standarddruckreihe / Standard pressure							
10.9										
–	1/2"	ZP 080	13	38,1	54	17,5	45,6	3	9	0,04
–	3/4"	ZP 100	19	47,6	65	22,3	52,0	3	11	0,05
–	1"	ZP 102	25	52,4	70	26,2	60,0	3	11	0,06
–	1 1/4"	ZP 104	32	58,7	79	30,2	68,0	3	11	0,08
–	1 1/2"	ZP 106	38	69,9	94	35,7	83,0	3	13	0,11
–	2"	ZP 108	51	77,8	102	42,9	90,0	3	13	0,12
–	2 1/2"	ZP 110	63	88,9	114	50,8	108,0	3	13	0,16
–	3"	ZP 112	73	106,4	134	61,9	130,0	4	17	0,29
–	3 1/2"	ZP 114	89	120,7	152	69,9	139,0	4	17	0,34
–	4"	ZP 116	99	130,2	162	77,8	152,0	4	17	0,38
–	5"	ZP 118	120	152,4	184	92,1	180,0	4	17	0,49
Schraube Festigkeitskl.			Hochdruckreihe / High pressure							
10.9										
–	1/2"	ZP 401	13	40,5	56	18,2	47,2	4	9	0,06
–	3/4"	ZP 402	17	50,8	71	23,8	60,0	4	11	0,07
–	1"	ZP 403	24	57,2	81	27,8	70,0	4	13	0,12
–	1 1/4"	ZP 404	31	66,6	95	31,8	78,0	4	15	0,15
–	1 1/2"	ZP 405	38	79,3	112	36,5	94,0	4	17	0,21
–	2"	ZP 406	51	96,8	133	44,5	114,0	4	21	0,28
–	2 1/2"	ZP 407	62	123,8	180	58,8	152,0	4	26	0,56

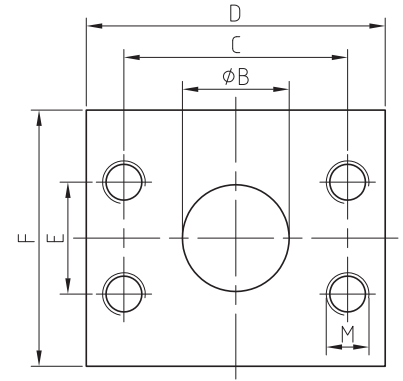
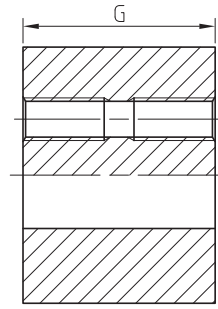

Bestellbezeichnung: ordering code:	S355J2*1 C45
• nur Flanschzwischenplatte connector flange only	ZFG-...

maximaler Betriebsdruck maximum recommended working pressure	S.A.E. Baugröße nominal flange size	Typ type	Abmessungen dimensions							Gewicht weight
			B	C	D	E	F	G	M	
kg/cm ²	inch									kg
Schraube Festigkeitskl.			Standarddruckreihe / Standard pressure							
10.9										
350	1/2"	ZFG-080	13	38,1	55	17,5	50	35	M 8	0,62
350	3/4"	ZFG-100	19	47,6	65	22,3	50	40	M 10	0,94
320	1"	ZFG-102	25	52,4	70	26,2	60	45	M 10	1,33
280	1 1/4"	ZFG-104	32	58,7	80	30,2	70	50	M 10	1,60
210	1 1/2"	ZFG-106	38	69,9	95	35,7	80	50	M 12	2,20
210	2"	ZFG-108	51	77,8	105	42,9	95	50	M 12	2,80
Schraube Festigkeitskl.			Hochdruckreihe / High pressure							
10.9										
420	1/2"	ZFG-401	13	40,5	55	18,2	50	35	M 8	0,62
420	3/4"	ZFG-402	19	50,8	70	23,8	60	45	M 10	1,41
420	1"	ZFG-403	25	57,2	80	27,8	70	50	M 12	1,64
420	1 1/4"	ZFG-404	32	66,6	95	31,8	80	50	M 14	2,90
420	1 1/2"	ZFG-405	38	79,3	115	36,5	95	60	M 16	4,30
420	2"	ZFG-406	51	96,8	135	44,5	115	65	M 20	6,20

*1 oder vergleichbare Güte / or comparable material

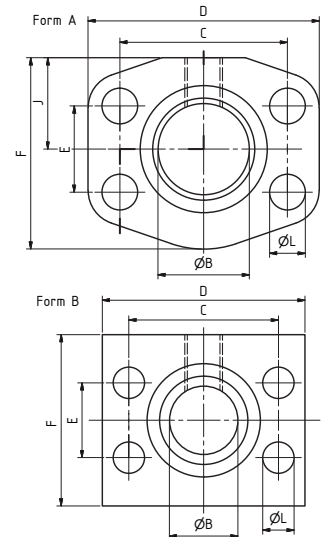
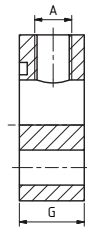

Bestellbezeichnung: ordering code:	S355J2*1	1.4404*1 316L
• nur Zwischenflansch adaptor-flange only	AGL-...	AGL-X-...

maximaler Betriebsdruck maximum recommended working pressure	S.A.E. Baugröße nominal flange size	Typ type	Abmessungen dimensions										Gewicht ohne Schrauben weight without bolts	
			A	B	C	D	E	F	G	J	L	kg		
kg/cm ²	inch													
Schraube Festigkeitskl. 10.9		Standarddruckreihe / Standard pressure												
350	1/2"	AGL-080	G 1/4"	12	38,1	56	17,5	38	24	19	9,0	0,28		
350	3/4"	AGL-100	G 1/4"	19	47,6	65	22,3	50	28	25	11,0	0,52		
320	1"	AGL-102	G 1/4"	24	52,4	71	26,2	57	24	27	11,0	0,47		
280	1 1/4"	AGL-104	G 1/4"	32	58,7	81	30,2	67	23	32	12,5	0,58		
210	1 1/2"	AGL-106	G 1/4"	38	69,9	95	35,7	76	24	37	13,5	0,80		
210	2"	AGL-108	G 1/4"	50	77,8	100	42,9	80	24	40	13,5	0,98		
175	2 1/2"	AGL-110	G 1/4"	63	88,9	114	50,8	103	25	50	13,5	1,21		
160	3"	AGL-112	G 1/4"	73	106,4	134	61,9	122	23	60	17,5	1,57		
35	3 1/2"	AGL-114	G 1/4"	89	120,7	152	69,9	138	25	68	17,0	2,12		
35	4"	AGL-116	G 1/4"	102	130,2	162	77,8	145	25	72	17,0	2,18		
35	5"	AGL-118	G 1/4"	127	152,4	190	92,1	169	26	84	17,5	2,69		
Schraube Festigkeitskl. 10.9		Hochdruckreihe / High pressure												
420	1/2"	AGL-401	G 1/4"	12	40,5	56	18,2	38	24	19	9,0	0,28		
420	3/4"	AGL-402	G 1/4"	19	50,8	71	23,8	57	24	27	11,0	0,50		
420	1"	AGL-403	G 1/4"	24	57,2	81	27,8	67	23	32	13,0	0,80		
420	1 1/4"	AGL-404	G 1/4"	32	66,6	96	31,8	77	24	37	15,0	0,80		
420	1 1/2"	AGL-405	G 1/4"	38	79,3	112	36,5	92	24	45	17,0	1,26		
420	2"	AGL-406	G 1/4"	50	96,8	134	44,5	112	24	55	21,0	1,78		
420	2 1/2"	AGL-407	G 1/4"	62	123,8	180	58,8	146	44	70	26,0	5,87		

*1 oder vergleichbare Güte / or comparable material

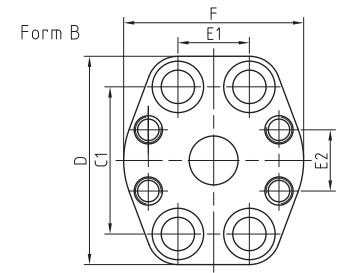
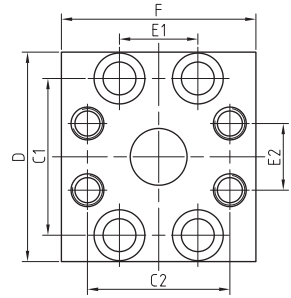
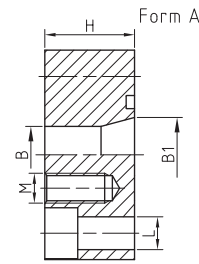

Bestellbezeichnung: ordering code:	S355J2^{*1}	1.4404^{*1} 316L
• nur Reduzierflansch flange only	G-AF-...	G-AF-X...

maximaler Betriebsdruck maximum recommended working pressure	S.A.E. Baugröße nominal flange size	Typ type	Abmessungen dimensions										Schrauben bolts		Gewicht weight		
			B1/B	C1	C2	D	E1	E2	F	H	L	M	metr.	unc.		kg	
kg/cm ²	inch																
Schraube Festigkeitskl. 10.9	Standarddruckreihe / Standard pressure													metr.	unc.		
320	1" - 3/4"	G-AF-303-302	25/19	52,4	47,6	70	26,2	22,3	65	30	11,0	M 10	M 10x30	–	0,78		
280	1 1/4" - 1"	G-AF-304-303	32/25	58,7	52,4	80	30,2	26,2	70	30	11,0	M 10	M 10x30	–	1,00		
210	1 1/2" - 1 1/4"	G-AF-305-304	38/32	69,9	58,7	95	35,7	30,2	80	30	13,5	M 10	M 12x35	–	1,32		
160	2" - 1 1/2"	G-AF-306-305	46/38	77,8	69,9	120	42,9	35,7	95	30	13,5	M 12	M 12x35	–	1,64		
160	2" - 1 1/4"	G-AF-306-304	51/32	77,8	58,7	102	42,9	30,2	80	35	13,5	M 10	M 12x40	–	1,60		
175	2 1/2" - 2"	G-AF-307-306	64/51	88,9	77,8	114	50,8	42,9	109	35	13,5	M 12	M 12x40	–	2,47		
175	2 1/2" - 1 1/2"	G-AF-307-305	62/38	88,9	69,9	114	50,8	35,7	109	35	13,5	M 12	M 12x40	–	2,61		
160	3" - 2"	G-AF-308-306	76/51	106,4	77,8	140	61,9	42,9	114	40	17,5	M 12	M 16x50	–	3,52		
160	3" - 2 1/2"	G-AF-308-307	76/64	106,4	88,9	140	61,9	50,8	114	40	17,5	M 12	M 16x50	–	3,30		
Schraube Festigkeitskl. 10.9	Hochdruckreihe / High pressure													metr.	unc.		
420	3/4" - 3/4"	G-AF-602-602	19	50,8	50,8	70	23,8	23,8	70	28	11	M 10	M 10x35	–	0,80		
420	1" - 1"	G-AF-603-603	25	57,2	57,2	80	27,8	27,8	75	36	13	M 12	M 12x45	–	1,10		
420	1" - 3/4"	G-AF-603-602	23/19	57,2	50,8	81	27,8	23,8	70	30	13	M 10	M 12x40	–	1,10		
420	1 1/4" - 1 1/4"	G-AF-604-604	31	66,6	66,6	100	31,8	31,8	90	35	15	M 14	M 14x40	–	1,40		
420	1 1/4" - 1"	G-AF-604-603	30/23	66,6	57,2	100	31,8	27,8	83	25	15	M 12	M 14x30	–	1,10		
420	1 1/2" - 1 1/2"	G-AF-605-605	38	79,3	79,3	113	36,5	36,5	113	50	17	M 16	M 16x55	–	3,30		
420	1 1/2" - 1 1/4"	G-AF-605-604	40/32	79,3	66,6	113	36,5	31,8	95	48	17	M 14	M 16x55	–	3,00		
420	2" - 1 1/2"	G-AF-606-605	49/38	96,8	79,3	140	44,5	36,5	125	60	22	M 16	M 20x60	–	5,30		
420	2 1/2" - 2"	G-AF-607-606	63/51	123,8	96,8	180	58,8	44,5	152	70	26	M 20	M 24x75	–	8,76		

*1 oder vergleichbare Güte / or comparable material

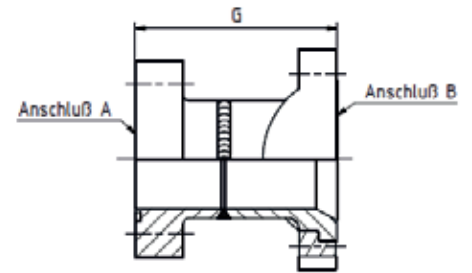
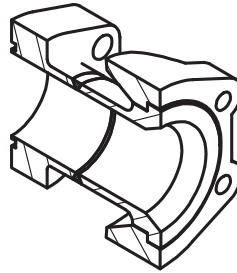

Bestellbezeichnung: ordering code:	S355J2¹ Steel
• Aufweitungsflansch; bestehend aus AFS, GSFS und VFG up size flange; AFS, GSFS and VFG	E-AF-.....

S.A.E. Baugröße nominal flange size	Typ type	Abmessungen dimensions			Schrauben bolts	Gewicht weight
		Anschluss A	Anschluss B	G		
inch					M	kg
Standarddruckreihe / Standard pressure						
1/2" - 3/4"	E-AF-301-302	1/2"	3/4"	88	M8x25	0,66
3/4" - 1"	E-AF-302-303	3/4"	1"	88	M10x35	0,87
1" - 1 1/4"	E-AF-303-304	1"	1 1/4"	95	M10x35	1,15
1 1/4" - 1 1/2"	E-AF-304-305	1 1/4"	1 1/2"	100	M10x40	1,64
1 1/2" - 2"	E-AF-305-306	1 1/2"	2"	103	M12x45	2,12
2" - 2 1/2"	E-AF-306-307	2"	2 1/2"	105	M12x45	2,77
2 1/2" - 3"	E-AF-307-308	2 1/2"	3"	110	M12x45	4,1
3" - 3 1/2"	E-AF-308-309	3"	3 1/2"	119	M16x50	5,39
3 1/2" - 4"	E-AF-309-310	3 1/2"	4"	125	M16x50	6,29
4" - 5"	E-AF-310-311	4"	5"	125	M16x50	8,59
Hochdruckreihe / High pressure						
1/2" - 3/4"	E-AF-601-602	1/2"	3/4"	76	M8x30	0,79
3/4" - 1"	E-AF-602-603	3/4"	1"	94	M10x35	1,42
1" - 1 1/4"	E-AF-603-604	1"	1 1/4"	108	M12x45	1,97
1 1/4" - 1 1/2"	E-AF-604-605	1 1/4"	1 1/2"	123	M14x50	3,3
1 1/2" - 2"	E-AF-605-606	1 1/2"	2"	136	M16x50	5,18
2" - 2 1/2"	E-AF-606-607	2"	2 1/2"	177	M20x70	10,33
2 1/2" - 3"	E-AF-607-608	2 1/2"	3"	213	M24x80	20,67

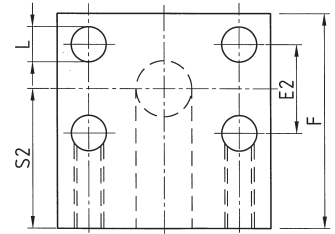
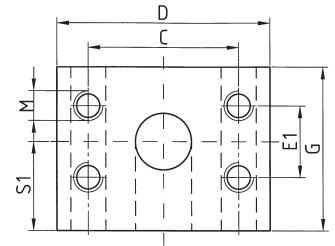
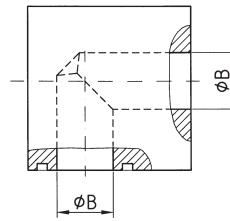

Bestellbezeichnung: ordering code:	S355J2^{*1}	1.4404^{*1} 316L
• nur Block block only	L-GD-...	L-GD-X-...

maximaler Betriebsdruck maximum recommended working pressure	S.A.E. Baugröße nominal flange size	Typ type	Abmessungen dimensions											Gewicht weight	
			B	C	D	E1	E2	F	G	L	M	S1	S2		kg
kg/cm ²	inch														
Schraube Festigkeitskl. 10.9		Standarddruckreihe / Standard pressure													
350	1/2"	L-GD 301	13	38,1	55	17,5	17,5	55	50	9,0	M 8	25,0	35	1,0	
350	3/4"	L-GD 302	19	47,6	65	22,3	22,3	60	60	11,0	M 10	30,0	40	1,2	
320	1"	L-GD 303	24	52,4	72	26,2	26,2	65	65	11,0	M 10	33,0	40	1,9	
280	1 1/4"	L-GD 304	32	58,7	82	30,2	30,2	82	80	11,0	M 10	39,0	38	3,5	
210	1 1/2"	L-GD 305	38	69,9	98	35,7	35,7	92	92	13,5	M 12	51,0	59	5,0	
210	2"	L-GD 306	46	77,8	102	42,9	42,9	85	87	13,5	M 12	51,0	48	7,9	
175	2 1/2"	L-GD 307	62	88,9	115	50,8	50,8	110	120	13,5	M 12	60,0	65	8,6	
160	3"	L-GD 308	73	106,4	135	61,9	61,9	150	135	17,5	M 16	67,5	90	10,5	
35	3 1/2"	L-GD 309	89	120,7	150	69,9	69,9	145	145	17,5	M 16	72,5	75	-	
Schraube Festigkeitskl. 10.9		Hochdruckreihe / High pressure													
420	1/2"	L-GD 601	13	40,5	60	18,2	18,2	60	50	9,0	M 8	25,0	40	1,0	
420	3/4"	L-GD 602	19	50,8	72	23,8	23,8	60	55	11,0	M 10	32,0	36	1,4	
420	1"	L-GD 603	23	57,2	82	27,8	27,8	68	64	14,0	M 12	37,0	40	2,3	
420	1 1/4"	L-GD 604	30	66,6	96	31,8	31,8	76	72	16,0	M 14	41,0	46	3,3	
420	1 1/2"	L-GD 605	38	79,3	114	36,5	36,5	86	89	18,0	M 16	50,0	52	5,4	
420	2"	L-GD 606	50	96,8	133	44,5	44,5	107	107	21,0	M 20	64,0	70	9,0	
420	2 1/2"	L-GD 607	62	123,8	180	58,8	58,8	160	155	26,0	M 24	77,5	90	14,6	

*1 oder vergleichbare Güte / or comparable material

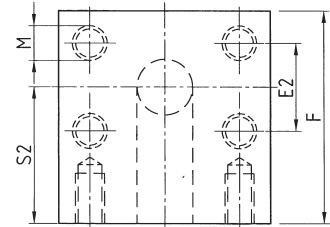
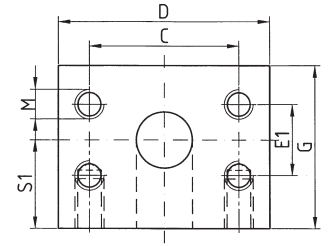
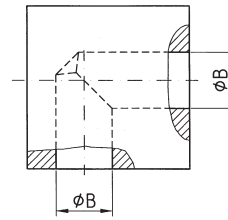

Bestellbezeichnung: ordering code:	S355J2^{*1}	1.4404^{*1} 316L
• nur Block block only	L-BL-...	L-BL-X...

maximaler Betriebsdruck maximum recommended working pressure	S.A.E. Baugröße nominal flange size	Typ type	Abmessungen dimensions									Gewicht weight	
			B	C	D	E	F	G	M	S1	S2		kg
kg/cm ²	inch												
Schraube Festigkeitskl.			Standarddruckreihe / Standard pressure										
10.9													
350	1/2"	L-BL-301	13	38,1	55	17,5	55	50	M 8	25,0	35	1,05	
350	3/4"	L-BL-302	19	47,6	65	22,3	60	60	M 10	30,0	40	1,56	
320	1"	L-BL-303	24	52,4	72	26,2	65	65	M 10	33,0	40	1,97	
280	1 1/4"	L-BL-304	32	58,7	82	30,2	82	80	M 10	39,0	38	2,64	
210	1 1/2"	L-BL-305	38	69,9	98	35,7	92	92	M 12	51,0	59	5,34	
210	2"	L-BL-306	51	77,8	102	42,9	85	87	M 12	51,0	48	4,20	
175	2 1/2"	L-BL-307	62	88,9	115	50,8	110	120	M 12	60,0	65	8,76	
160	3"	L-BL-308	73	106,4	135	61,9	150	135	M 16	67,5	90	15,87	
35	3 1/2"	L-BL-309	89	120,7	150	69,9	145	145	M 16	72,5	75	29,87	
Schraube Festigkeitskl.			Hochdruckreihe / High pressure										
10.9													
420	1/2"	L-BL-601	13	40,5	60	18,2	60	50	M 8	25,0	40	1,26	
420	3/4"	L-BL-602	19	50,8	72	23,8	60	55	M 10	32,0	36	1,59	
420	1"	L-BL-603	23	57,2	82	27,8	72	72	M 12	44,0	44	2,90	
420	1 1/4"	L-BL-604	30	66,6	96	31,8	72	72	M 14	41,0	46	3,17	
420	1 1/2"	L-BL-605	38	79,3	114	36,5	86	89	M 16	50,0	52	5,63	
420	2"	L-BL-606	50	96,8	133	44,5	113	113	M 20	70,0	70	10,60	
420	2 1/2"	L-BL-607	62	123,8	180	58,8	160	155	M 24	77,5	90	29,05	

*1 oder vergleichbare Güte / or comparable material

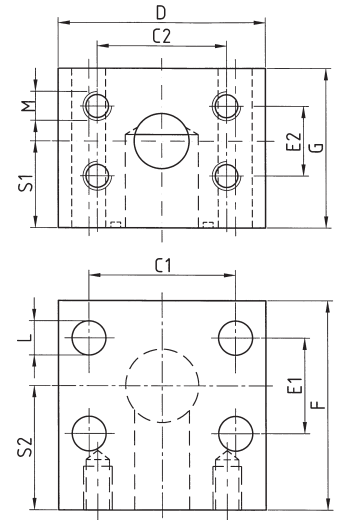
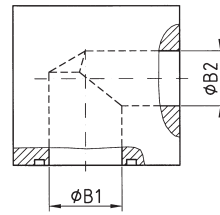

Bestellbezeichnung: ordering code:	S355J2^{*1}	1.4404^{*1} 316L
• nur Block block only	RED-GD-...	RED-GD-X-...

maximaler Betriebsdruck maximum recommended working pressure	S.A.E. Baugröße nominal flange size	Typ type	Abmessungen dimensions													Gewicht weight
			B1	B2	C1	C2	D	E1	E2	F	G	L	M	S1	S2	
kg/cm ²	inch															
Schraube Festigkeitskl.			Hochdruckreihe / High pressure													
10.9																
420	1" - 3/4"	RED-GD 603-602	23	19	57,2	50,8	82	27,8	23,8	68	64	14	M 10	37	40	2,2
420	1 1/4" - 3/4"	RED-GD 604-602	30	19	66,6	50,8	96	31,8	23,8	76	72	16	M 10	41	46	3,6
420	1 1/4" - 1"	RED-GD 604-603	30	23	66,6	57,2	96	31,8	27,8	76	72	16	M 12	41	46	3,3
420	1 1/2" - 1 1/4"	RED-GD 605-604	38	30	79,3	66,6	114	36,5	31,8	86	89	19	M 14	50	52	5,7
420	2" - 1 1/2"	RED-GD 606-605	50	38	96,8	79,3	133	44,5	36,5	110	110	21	M 16	64	70	9,0

*1 oder vergleichbare Güte / or comparable material

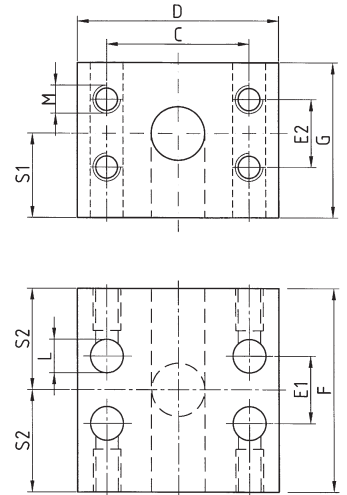
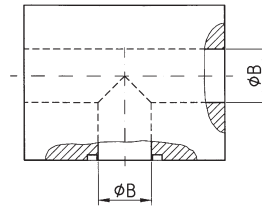

Bestellbezeichnung: ordering code:	S355J2^{*1}	1.4404^{*1} 316L
• nur Block block only	T-GD-...	T-GD-X...

maximaler Betriebsdruck maximum recommended working pressure	S.A.E. Baugröße nominal flange size	Typ type	Abmessungen dimensions											Gewicht weight	
			B	C	D	E1	E2	F	G	L	M	S1	S2		kg
kg/cm ²	inch														
Schraube Festigkeitskl.	Hochdruckreihe / High pressure														
10.9															
420	¾"	T-GD 602-602	19	50,8	72	23,8	23,8	72	55	11	M 10	32	36,0	1,7	
420	1"	T-GD 603-603	23	57,2	82	27,8	27,8	90	64	14	M 12	37	45,0	2,9	
420	1¼"	T-GD 604-604	30	66,6	96	31,8	31,8	100	72	16	M 14	41	50,0	3,8	
420	1½"	T-GD 605-605	38	79,3	114	36,5	36,5	107	89	18	M 16	50	53,5	6,2	
420	2"	T-GD 606-606	50	96,8	133	44,5	44,5	135	107	22	M 20	64	67,5	12,7	

*1 oder vergleichbare Güte / or comparable material

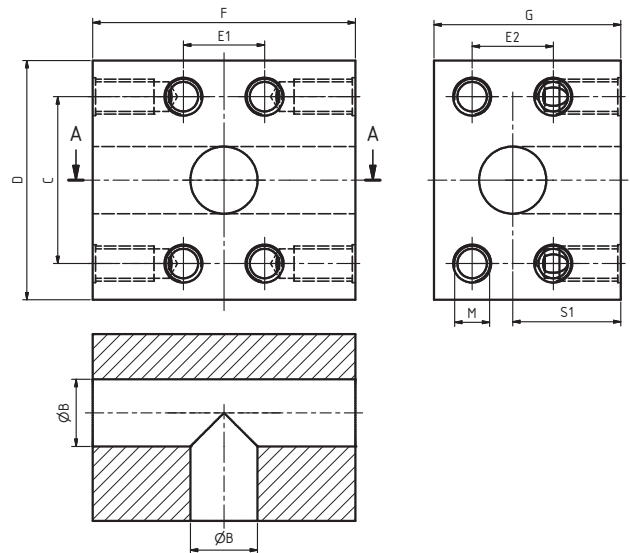

Bestellbezeichnung: ordering code:	S355J2*1	1.4404*1 316L
• nur Block block only	T-BL-...	T-BL-X...

maximaler Betriebsdruck maximum recommended working pressure	S.A.E. Baugröße nominal flange size	Typ type	Abmessungen dimensions									Gewicht weight		
			B	C	D	E1	E2	F	G	S ₁	M		kg	
kg/cm ²	inch													
Schraube Festigkeitskl.			Standarddruckreihe / Standard pressure											
10.9														
350	1/2"	T-BL-301-301	13	38,1	55	17,5	17,5	70	50	25,0	M 8	1,4		
350	3/4"	T-BL-302-302	19	47,6	65	22,3	22,3	75	55	27,5	M 10	1,8		
320	1"	T-BL-303-303	25	52,4	70	26,2	26,2	80	60	30,0	M 10	2,3		
280	1 1/4"	T-BL-304-304	32	58,7	80	30,2	30,2	90	70	35,0	M 10	3,9		
210	1 1/2"	T-BL-305-305	38	69,9	95	35,7	35,7	110	85	42,5	M 12	6,3		
210	2"	T-BL-306-306	50	77,8	110	42,9	42,9	120	100	50,0	M 12	8,3		
175	2 1/2"	T-BL-307-307	63	88,9	110	50,8	50,8	160	120	60,0	M 12	11,6		
160	3"	T-BL-308-308	73	106,4	135	61,9	61,9	160	160	80,0	M 16	15,3		
35	3 1/2"	T-BL-309-309	89	120,7	150	69,9	69,9	160	145	72,5	M 16	16,2		
Schraube Festigkeitskl.			Hochdruckreihe / High pressure											
10.9														
420	1/2"	T-BL-601-601	13	40,5	60	18,2	18,2	90	50	25,0	M 8	1,3		
420	3/4"	T-BL-602-602	19	50,8	70	23,8	23,8	72	55	32,0	M 10	1,7		
420	1"	T-BL-603-603	23	57,2	82	27,8	27,8	90	64	37,0	M 12	2,9		
420	1 1/4"	T-BL-604-604	30	66,6	96	31,8	31,8	100	72	41,0	M 14	3,8		
420	1 1/2"	T-BL-605-605	38	79,3	110	36,5	36,5	107	100	50,0	M 16	8,9		
420	2"	T-BL-606-606	50	96,8	133	44,5	44,5	135	107	64,0	M 20	12,7		
420	2 1/2"	T-BL-607-607	62	123,8	180	58,8	58,8	180	155	77,5	M 24	16,5		

*1 oder vergleichbare Güte / or comparable material

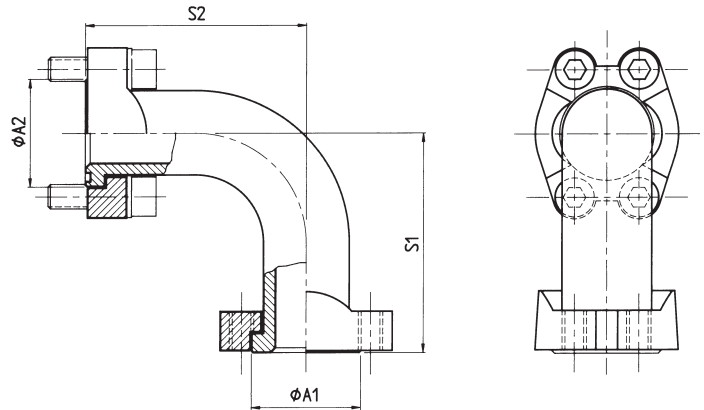

Bestellbezeichnung: ordering code:	Stahl Steel
• nur Zwischenstück elbow only	AG-...

maximaler Betriebsdruck maximum recommended working pressure	S.A.E. Baugröße nominal flange size	Typ type	Abmessungen dimensions		Gewicht weight
			A1 / A2	S1 / S2	
kg/cm ²	inch				kg
Schraube Festigkeitskl.					
10.9	Standarddruckreihe / Standard pressure				
350	1/2"	AG 3001 90° *	30,2	71	0,57
350	1/2"	AG 3001 90° N	30,2	59	0,51
350	3/4"	AG 3002 90° *	38,1	81	0,93
350	3/4"	AG 3002 90° N	38,1	63	0,78
320	1"	AG 3003 90° *	44,5	90	1,15
320	1"	AG 3003 90° N	44,5	74	1,12
280	1 1/4"	AG 3004 90° *	50,8	104	1,57
280	1 1/4"	AG 3004 90° N	50,8	84	1,58
210	1 1/2"	AG 3005 90° *	60,3	116	2,20
210	1 1/2"	AG 3005 90° N	60,3	94	2,10
210	2"	AG 3006 90° *	71,4	135	3,08
210	2"	AG 3006 90° N	71,4	113	2,70
175	2 1/2"	AG 3007 90° *	84,1	155	4,98
175	2 1/2"	AG 3007 90° N	84,1	145	4,74
160	3"	AG 3008 90° *	101,6	174	7,80
160	3"	AG 3008 90° N	101,6	167	7,49
35	3 1/2"	AG 3009 90° *	114,3	176	8,80
35	3 1/2"	AG 3009 90° N	114,3	154	7,46
35	4"	AG 3010 90° *	127,0	214	11,91
35	4"	AG 3010 90° N	127,0	199	11,21
35	5"	AG 3011 90°	152,4	252	18,54

* auslaufender Artikel

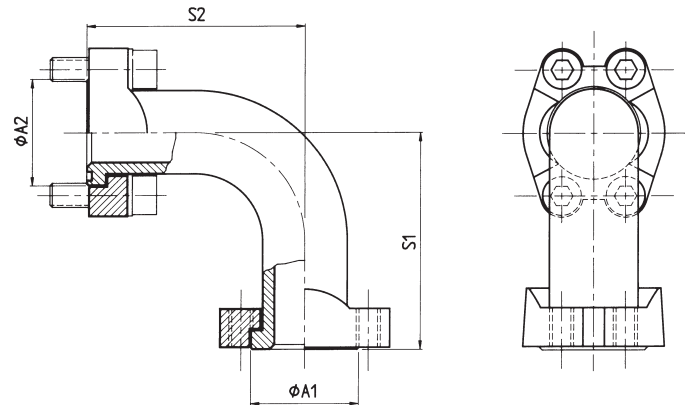

Bestellbezeichnung: ordering code:	Stahl Steel
• nur Zwischenstück elbow only	AG-...

maximaler Betriebsdruck maximum recommended working pressure	S.A.E. Baugröße nominal flange size	Typ type	Abmessungen dimensions				Gewicht weight
			A1	A2	S1	S2	
kg/cm ²	inch						kg
Schraube Festigkeitskl. 10.9	Hochdruckreihe / High pressure						
420	1/2"	AG 6001 90°	31,8	31,8	64	64	0,64
420	3/4"	AG 6002 90°	41,3	41,3	69	69	1,19
420	1"	AG 6003 90°	47,6	47,6	80	80	1,86
420	1 1/4"	AG 6004 90°	54,0	54,0	95	95	2,77
420	1 1/2"	AG 6005 90°	63,5	63,5	109	109	4,68
420	2"	AG 6006 90°	79,4	79,4	136	136	7,62

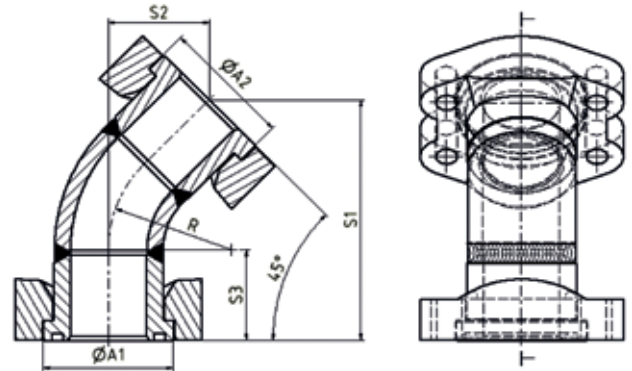

Bestellbezeichnung: ordering code:	Stahl Steel
• nur Zwischenstück elbow only	AG-...

maximaler Betriebsdruck maximum recommended working pressure	S.A.E. Baugröße nominal flange size	Typ type	Abmessungen dimensions						Gewicht weight
			A1	A2	S1	S2	S3	R	
kg/cm ²	inch								kg
Schraube Festigkeitskl. 10.9	Standarddruckreihe / Standard pressure								
350	1/2"	AG 3001 45°	30,2	30,2	72,7	30,1	31	28	0,47
350	3/4"	AG 3002 45°	38,1	38,1	78,5	32,5	34	29	0,72
320	1"	AG 3003 45°	44,5	44,5	88,3	36,6	36	38	0,99
280	1 1/4"	AG 3004 45°	50,8	50,8	95,4	39,5	36	48	1,37
210	1 1/2"	AG 3005 45°	60,3	60,3	103,5	42,9	37	57	1,81
210	2"	AG 3006 45°	71,4	71,4	117,0	48,0	37	76	2,25
175	2 1/2"	AG 3007 45°	84,1	84,1	152,5	63,2	50	95	3,92
160	3"	AG 3008 45°	101,6	101,6	171,1	70,9	53	114	6,07
35	3 1/2"	AG 3009 45°	114,3	114,3	148,9	61,7	40	114	6,04
35	4"	AG 3010 45°	127,0	127,0	187,7	77,8	47	152	8,48

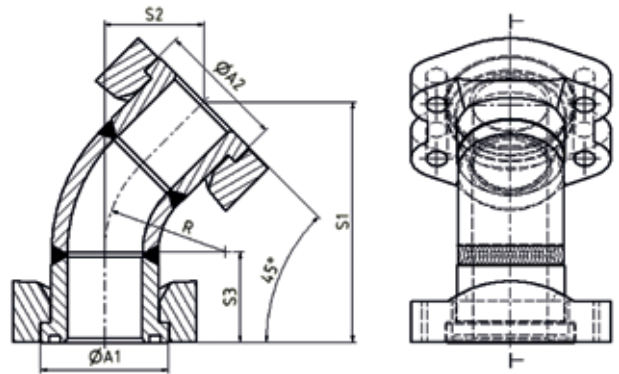

Bestellbezeichnung: ordering code:	Stahl Steel
• nur Zwischenstück elbow only	AG-...

maximaler Betriebsdruck maximum recommended working pressure	S.A.E. Baugröße nominal flange size	Typ type	Abmessungen dimensions						Gewicht weight
			A1	A2	S1	S2	S3	R	
kg/cm ²	inch								kg
Schraube Festigkeitskl. 10.9	Hochdruckreihe / High pressure								
420	1/2"	AG 6001 45°	31,8	31,8	81,3	33,7	36	28	0,59
420	3/4"	AG 6002 45°	41,3	41,3	88,5	36,8	40	29	1,12
420	1"	AG 6003 45°	47,6	47,6	98,6	40,8	42	38	1,75
420	1 1/4"	AG 6004 45°	54,0	54,0	114,2	47,3	47	48	2,56
420	1 1/2"	AG 6005 45°	63,5	63,5	129,1	53,5	52	57	4,39
420	2"	AG 6006 45°	79,4	79,4	156,2	64,7	60	76	7,16

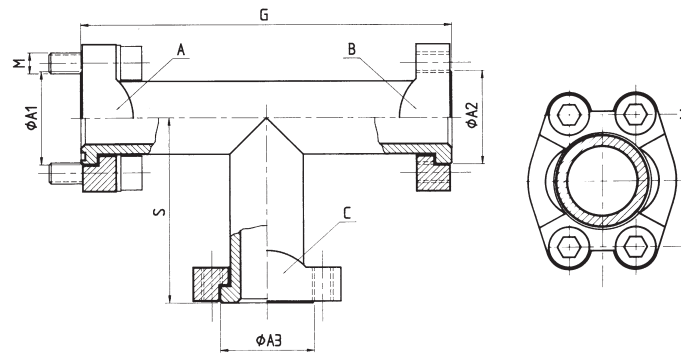

Bestellbezeichnung: ordering code:	Stahl Steel
• nur T-Stück T-connection only	T-...

maximaler Betriebsdruck maximum recommended working pressure	Typ type	Anschluss A connection A			Anschluss B connection B		Anschluss C connection C		G	S	Gewicht weight
		size	A1	M	size	A2	size	A3			
kg/cm ²											
Schraube Festigkeitskl.	Standarddruckreihe / Standard pressure										
10.9											
350	T 301 A-301 G-301 G	1/2"	30,2	M 8x30	1/2"	30,2	1/2"	30,2	133	67	0,97
350	T 302 A-302 G-302 G	3/4"	38,1	M 10x35	3/4"	38,1	3/4"	38,1	160	80	1,20
350	T 302 A-302 G-301 G	3/4"	38,1	M 10x35	3/4"	38,1	1/2"	30,2	160	67	1,14
320	T 303 A-303 G-303 G	1"	44,4	M 10x35	1"	44,4	1"	44,4	177	88	1,63
320	T 303 A-303 G-302 G	1"	44,4	M 10x35	1"	44,4	3/4"	38,1	177	80	1,50
320	T 303 A-303 G-301 G	1"	44,4	M 10x35	1"	44,4	1/2"	30,2	177	67	1,39
280	T 304 A-304 G-304 G	1 1/4"	50,8	M 10x30	1 1/4"	50,8	1 1/4"	50,8	208	103	2,25
280	T 304 A-304 G-303 G	1 1/4"	50,8	M 10x30	1 1/4"	50,8	1"	44,4	208	88	2,05
280	T 304 A-304 G-302 G	1 1/4"	50,8	M 10x30	1 1/4"	50,8	3/4"	38,1	208	80	1,94
210	T 305 A-305 G-305 G	1 1/2"	60,3	M 12x35	1 1/2"	60,3	1 1/2"	60,3	230	115	3,50
210	T 305 A-305 G-304 G	1 1/2"	60,3	M 12x35	1 1/2"	60,3	1 1/4"	50,8	230	103	3,03
210	T 305 A-305 G-303 G	1 1/2"	60,3	M 12x35	1 1/2"	60,3	1"	44,4	230	88	2,94
210	T 306 A-306 G-306 G	2"	71,4	M 12x35	2"	71,4	2"	71,4	244	122	4,20
210	T 306 A-306 G-305 G	2"	71,4	M 12x35	2"	71,4	1 1/2"	60,3	244	118	4,05
210	T 306 A-306 G-304 G	2"	71,4	M 12x35	2"	71,4	1 1/4"	50,8	244	115	3,87
175	T 307 A-307 G-307 G	2 1/2"	84,1	M 12x40	2 1/2"	84,1	2 1/2"	84,1	270	135	4,70
175	T 307 A-307 G-306 G	2 1/2"	84,1	M 12x40	2 1/2"	84,1	2"	74,1	270	128	4,30
175	T 307 A-307 G-305 G	2 1/2"	84,1	M 12x40	2 1/2"	84,1	1 1/2"	60,3	270	125	4,10
138	T 308 A-308 G-308 G	3"	101,6	M 16x50	3"	101,6	3"	101,6	293	146	8,20
138	T 308 A-308 G-307 G	3"	101,6	M 16x50	3"	101,6	2 1/2"	84,1	293	141	7,50
138	T 308 A-308 G-306 G	3"	101,6	M 16x50	3"	101,6	2"	71,4	293	133	7,20
35	T 309 A-309 G-309 G	3 1/2"	114,3	M 16x50	3 1/2"	114,3	3 1/2"	114,3	293	146	9,55
35	T 309 A-309 G-308 G	3 1/2"	114,3	M 16x50	3 1/2"	114,3	3"	101,6	293	146	9,20
35	T 309 A-309 G-307 G	3 1/2"	114,3	M 16x50	3 1/2"	114,3	2 1/2"	84,1	293	146	8,50
35	T 310 A-310 G-310 G	4"	127,0	M 16x50	4"	127,0	4"	127,0	332	165	12,10
35	T 310 A-310 G-309 G	4"	127,0	M 16x50	4"	127,0	3 1/2"	114,3	332	158	11,60
35	T 310 A-310 G-308 G	4"	127,0	M 16x50	4"	127,0	3"	101,6	332	158	10,95
35	T 311 A-311 G-311 G	5"	152,4	M 16x55	5"	152,4	5"	152,4	370	185	14,70
35	T 311 A-311 G-310 G	5"	152,4	M 16x55	5"	152,4	4"	127,0	370	177	13,95
35	T 311 A-311 G-309 G	5"	152,4	M 16x55	5"	152,4	3 1/2"	114,3	370	170	13,10

*1 oder vergleichbare Güte / or comparable material **Wichtig:** Alle Anschlüsse A, B und C können wahlweise mit O-Ringnut (Type A) oder ohne O-Ring (Type G) geliefert werden! / **Important:** All connections A, B and C can be supplied as requested with o-ring groove (type A) or without o-ring groove (type G)!

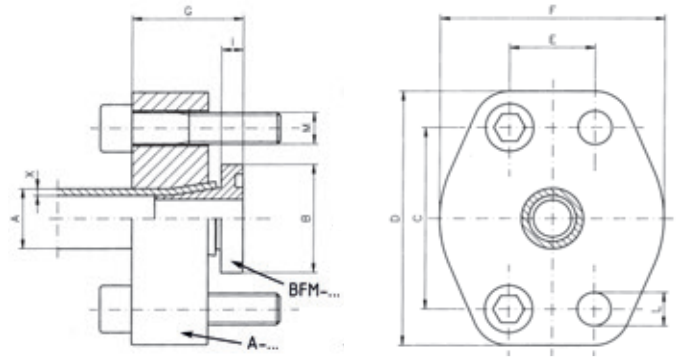

Bestellbezeichnung: ordering code:	C45*1 C45
• nur Bördelflansch flare flange only	A-...
• nur Bördelflansch mit Nut flare flange only with o-ring groove	BFM-...
• Bördelflansch komplett mit Bördelinnenteil mit Nut, Schrauben und O-Ring Flare flange complete with flare flange interior with o-ring groove, bolts and o-ring	BFM-... M

maximaler Betriebsdruck maximum recommended working pressure	S.A.E. Baugröße nominal flange size	Typ type	Abmessungen dimensions										Schrauben bolts	Gewicht weight	
			Rohr AxX	B	C	D	E	F	G	I	L	M			kg
kg/cm ²	inch														
Schraube Festigkeitskl. 10.9	Standarddruckreihe / Standard pressure														
420	¾"	BFM-402-25 x 3M	25 x 3	38,10	50,8	71	23,8	60	37,5	8,6	11	M 10x40	0,57		
420	¾"	BFM-402-25 x 4M	25 x 4	38,10	50,8	71	23,8	60	37,5	8,6	11	M 10x40	0,57		
420	1"	BFM-403-30 x 4M	30 x 4	47,60	57,2	81	27,8	71	42,5	9,0	13	M 12x40	0,89		
420	1"	BFM-403-30 x 5M	30 x 5	47,60	57,2	81	27,8	71	42,5	9,0	13	M 12x40	0,89		
420	1¼"	BFM-404-38 x 5M	38 x 5	51,90	66,6	95	31,8	81	44,0	9,2	15	M 14x50	1,05		
420	1¼"	BFM-404-38 x 6M	38 x 6	51,90	66,6	95	31,8	81	44,0	9,2	15	M 14x50	1,05		
420	1½"	BFM-405-50 x 6M	50 x 6	63,50	79,3	114	36,5	96	57,0	10,2	17	M 16x60	2,07		
420	1½"	BFM-405-50 x 8M	50 x 8	63,50	79,3	114	36,5	96	57,0	10,2	17	M 16x60	2,06		
420	2"	BFM-406-65 x 8M	65 x 8	75,20	96,8	134	44,5	114	65,0	11,1	21	M 20x90	2,90		

*1 Flansch: C45, Bördelteil: 42CrMo4V / Flange: C45, Flare part: 42CrMo4V

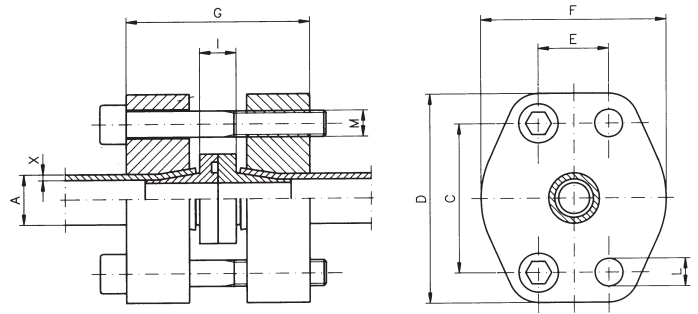

Bestellbezeichnung: ordering code:	C45*1 C45
• Flanschkupplung komplett flange-coupling	BFK-...-M

maximaler Betriebsdruck maximum recommended working pressure	S.A.E. Baugröße nominal flange size	Typ type	Abmessungen dimensions								Schrauben bolts	Gewicht weight	
			Rohr A x X	C	D	E	F	G	I	L			M
kg/cm ²	inch												
Schraube Festigkeitskl. 10.9	Hochdruckreihe / High pressure												
420	¾"	BFK-402-25 x 3M	25 x 3	50,8	71	23,8	60	75	14,2	11	M 10x60	1,14	
420	¾"	BFK-402-25 x 4M	25 x 4	50,8	71	23,8	60	75	14,2	11	M 10x60	1,14	
420	1"	BFK-403-30 x 4M	30 x 4	57,2	81	27,8	71	85	18,0	13	M 12x70	1,78	
420	1"	BFK-403-30 x 5M	30 x 5	57,2	81	27,8	71	85	18,0	13	M 12x70	1,78	
420	1¼"	BFK-404-38 x 5M	38 x 5	66,6	95	31,8	81	88	18,4	15	M 14x80	2,10	
420	1¼"	BFK-404-38 x 6M	38 x 6	66,6	95	31,8	81	88	18,4	15	M 14x80	2,10	
420	1½"	BFK-405-50 x 6M	50 x 6	79,3	114	36,5	96	114	17,4	17	M 16x90	4,14	
420	1½"	BFK-405-50 x 8M	50 x 8	79,3	114	36,5	96	114	17,4	17	M 16x90	4,10	
420	2"	BFK-406-65 x 8M	65 x 8	96,8	134	44,5	114	130	19,2	21	M 20x120	5,80	

*1 Flansch: C45, Bördelteil: 42CrMo4V / Flange: C45, Flare part: 42CrMo4V

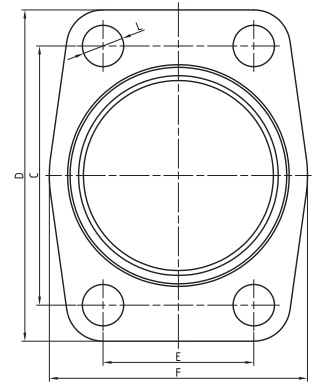
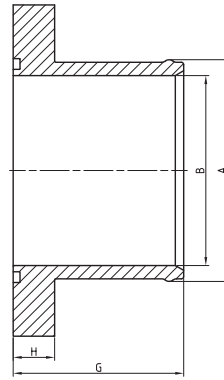

Bestellbezeichnung: ordering code:	S355J2 *1
• nur Flansch flange only	SHFL-...

maximaler Betriebsdruck maximum recommended working pressure	S.A.E. Baugröße nominal flange size	Typ type	Abmessungen dimensions										Schrauben bolts		Gewicht weight
			A	B	C	D	E	F	G	H	L	M	kg		
kg/cm ²	inch														
Schraube Festigkeitskl.		Standarddruckreihe / Standard pressure										metr.	unc.		
10.9															
10	2"	SHFL-3006-62	62	48	77,8	103	42,9	70	70	16	13,5	M 12x35	1/2 x 1 3/4	0,96	
10	2 1/2"	SHFL-3007-62	62	50	88,9	114	50,8	84	70	19	13,5	M 12x40	1/2 x 1 3/4	1,24	
10	3"	SHFL-3008-91	91	78	106,4	138	61,9	108	70	17	17,0	M 16x50	5/8 x 2	1,58	
10	3 1/2"	SHFL-3009-116	116	89	120,7	152	69,9	136	91	18	17,0	M 16x50	5/8 x 2	3,29	

Oberfläche: CR-6: auslaufend/Neu: CR-6 frei / surface: CR-6: phase-out/New: CR-6 free

*1 oder vergleichbare Güte / or comparable material

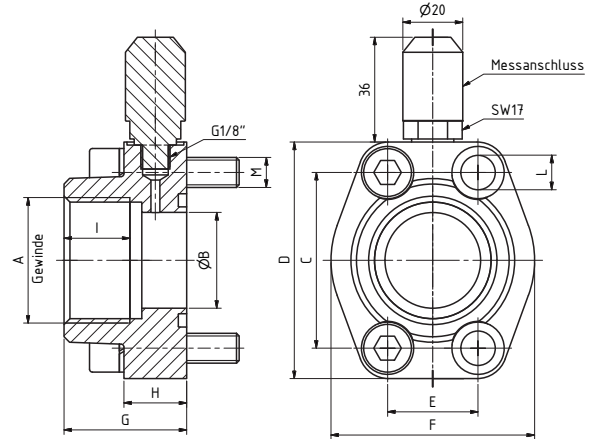

Bestellbezeichnung: ordering code:	S355J2¹	1.4404¹ 316L
• nur Flansch flange only	AFS-...G-A1K	AFX-...G-A1K
• incl. metrischem Schraubensatz und O-Ring including metric bolts and o-ring	AFS-...G-A1K-M	AFX-...G-A1K-MX
• incl. UNC Schraubensatz und O-Ring including unc bolts and o-ring	AFS-...G-A1K-U	AFX-...G-A1K-UX
• incl. metrischem Schraubensatz, O-Ring und Messanschluss including metric bolts, o-ring and test coupling	AFS-...G-A1K-MM	AFX-...G-A1K-MM
• incl. UNC Schraubensatz, O-Ring und Messanschluss including unc bolts, o-ring and test coupling	AFS-...G-A1K-UM	AFX-...G-A1K-UM

maximaler Betriebsdruck maximum recommended working pressure	S.A.E. Baugröße nominal flange size	Typ type	Abmessungen dimensions											Messanschluss	Schrauben bolts		Gewicht weight
			A	B	C	D	E	F	G	H	I	L	M		kg		
kg/cm ²	inch														metr.	unc.	kg
Schraube Festigkeitskl. 10.9	Standarddruckreihe / Standard pressure																
280	1 1/4"	AFS 104 G-A1K	G 1 1/4"	32	58,7	79	30,2	68	41	21	22	11,5	G1/8"	M 10x40	7/16 x 1 1/2	0,66	
280	1 1/4"	AFS 104 G L=13-A1K	G 1 1/4"	32	58,7	79	30,2	68	41	21	22	13,0	G1/8"	M 12x40	-	0,66	
280	1 1/4"	AFS 104 G-100-A1K	G 1"	25	58,7	81	30,2	65	42	25	22	11,5	G1/8"	M 10x40	7/16 x 1 3/4	0,75	
280	1 1/4"	AFS 104 G-100 L=13-A1K	G 1"	25	58,7	81	30,2	65	42	25	22	13,0	G1/8"	M 12x40	-	0,75	
280	1 1/4"	AFS 104 G-034-A1K	G 3/4"	19	58,7	79	30,2	68	41	21	22	11,5	G1/8"	M 10x40	7/16 x 1 1/2	0,79	
210	1 1/2"	AFS 106 G-A1K	G 1 1/2"	38	69,9	93	35,7	78	45	25	24	13,5	G1/8"	M 12x45	1/2 x 1 3/4	1,05	
210	1 1/2"	AFS 106 G-114-A1K	G 1 1/4"	32	69,9	95	35,7	78	45	27	24	13,5	G1/8"	M 12x45	1/2 x 1 3/4	1,10	
210	1 1/2"	AFS 106 G-100-A1K	G 1"	25	69,9	93	35,7	78	45	25	24	13,5	G1/8"	M 12x45	1/2 x 1 3/4	1,16	
210	1 1/2"	AFS 106 G-034-A1K	G 3/4"	19	69,9	93	35,7	78	45	25	24	13,5	G1/8"	M 12x45	1/2 x 1 3/4	1,23	
210	2"	AFS 108 G-A1K	G 2"	51	77,8	102	42,9	90	45	25	30	13,5	G1/8"	M 12x45	1/2 x 1 3/4	1,19	
210	2"	AFS 108 G-112-A1K	G 1 1/2"	38	77,8	102	42,9	90	45	25	26	13,5	G1/8"	M 12x45	1/2 x 1 3/4	1,25	
210	2"	AFS 108 G-114-A1K	G 1 1/4"	32	77,8	102	42,9	90	45	25	24	13,5	G1/8"	M 12x45	1/2 x 1 3/4	1,40	
210	2"	AFS 108 G-100-A1K	G 1"	25	77,8	102	42,9	90	45	25	22	13,5	G1/8"	M 12x45	1/2 x 1 3/4	1,44	
175	2 1/2"	AFS 110 G-A1K	G 2 1/2"	63	88,9	114	50,8	105	50	25	30	13,5	G1/8"	M 12x45	1/2 x 1 3/4	1,40	
175	2 1/2"	AFS 110 G-200-A1K	G 2"	51	88,9	114	50,8	105	50	25	30	13,5	G1/8"	M 12x45	1/2 x 1 3/4	1,45	
160	3"	AFS 112 G-A1K	G 3"	73	106,4	134	61,9	124	50	27	34	17,5	G1/8"	M 16x50	5/8 x 2	2,15	
160	3"	AFS 112 G-G112-A1K	G 1 1/2"	38	106,4	134	61,9	124	50	27	25	17,5	G1/8"	M16x50	5/8 x 2	3,70	
160	3"	AFS 112 G-212-A1K	G 2 1/2"	63	106,4	134	61,9	124	50	27	30	17,5	G1/8"	M 16x50	5/8 x 2	2,25	
35	3 1/2"	AFS 114 G-A1K	G 3 1/2"	89	120,7	152	69,9	136	48	27	34	17,5	G1/8"	M 16x50	5/8 x 2	2,40	
35	3 1/2"	AFS 114 G-300-A1K	G 3"	73	120,7	152	69,9	136	48	27	34	17,5	G1/8"	M 16x50	5/8 x 2	2,50	
35	4"	AFS 116 G-A1K	G 4"	99	130,2	162	77,8	146	48	27	34	17,5	G1/8"	M 16x50	5/8 x 2	2,85	
35	4"	AFS 116 G-312-A1K	G 3 1/2"	89	130,2	162	77,8	146	48	27	34	17,5	G1/8"	M 16x50	5/8 x 2	3,00	
35	5"	AFS 118 G-A1K	G 5"	120	152,4	184	92,1	180	50	28	30	17,5	G1/8"	M 16x55	5/8 x 2	5,80	

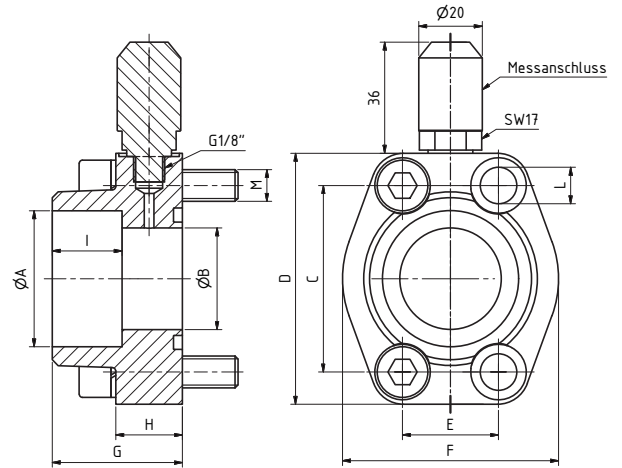

Bestellbezeichnung: ordering code:	S355J2^{*1}	1.4404^{*1} 316L
• nur Flansch flange only	AFS-...S-A1K	AFX-...S-A1K
• incl. metrischem Schraubensatz und O-Ring including metric bolts and o-ring	AFS-...S-A1K-M	AFX-...S-A1K-MX
• incl. UNC Schraubensatz und O-Ring including unc bolts and o-ring	AFS-...S-A1K-U	AFX-...S-A1K-UX
• incl. metrischem Schraubensatz, O-Ring und Messanschluss including metric bolts, o-ring and test coupling	AFS-...S-A1K-MM	AFX-...S-A1K-MM
• incl. UNC Schraubensatz, O-Ring und Messanschluss including unc bolts, o-ring and test coupling	AFS-...S-A1K-UM	AFX-...S-A1K-UM

maximaler Betriebsdruck maximum recommended working pressure	S.A.E. Baugröße nominal flange size	Typ type	Abmessungen dimensions											Mess-anschluss	Schrauben bolts		Gewicht weight
			A	B	C	D	E	F	G	H	I	L	M			kg	
kg/cm ²	inch		Standarddruckreihe / Standard pressure												metr.	unc.	
Schraube Festigkeitskl. 10.9																	
280	1¼"	AFS-104S-A1K	42,8	32	58,7	79	30,2	68	41	21	22	11,5	G1/8"	M 10x40	7/16 x 1½	0,66	
210	1½"	AFS-106S-A1K	48,6	38	69,9	93	35,7	78	45	25	24	13,5	G1/8"	M 12x45	½ x 1¾	1,05	
210	2"	AFS-108S-A1K	61,0	51	77,8	102	42,9	90	45	25	26	13,5	G1/8"	M 12x45	½ x 1¾	1,19	
175	2½"	AFS-110S-A1K	76,6	63	88,9	114	50,8	105	50	25	30	13,5	G1/8"	M 12x45	½ x 1¾	1,40	
160	3"	AFS-112S-A1K	90,5	73	106,4	134	61,9	124	50	27	34	17,5	G1/8"	M 16x50	5/8 x 2	2,15	
35	3½"	AFS-114S-A1K	103,0	89	120,7	152	69,9	136	48	27	34	17,5	G1/8"	M 16x50	5/8 x 2	2,40	
35	4"	AFS-116S-A1K	115,5	99	130,2	162	77,8	146	48	27	34	17,5	G1/8"	M 16x50	5/8 x 2	2,85	
35	5"	AFS-118S-A1K	142,0	120	152,4	184	92,1	181	50	28	28	17,5	G1/8"	M 16x55	5/8 x 2	5,80	

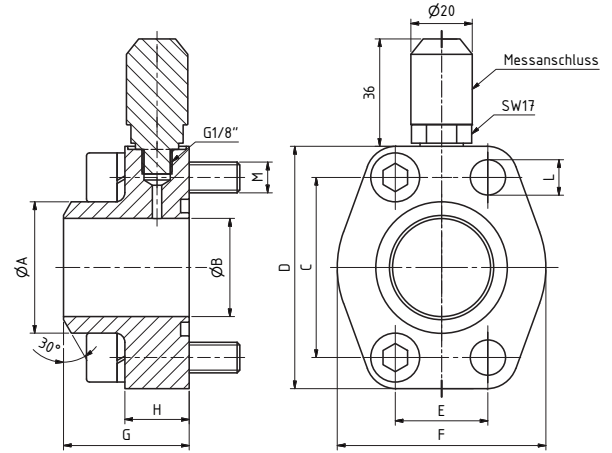

Bestellbezeichnung: ordering code:	S355J2^{*1}	1.4404^{*1} 316L
• nur Flansch flange only	AFS-...ST-A1K	AFX-...ST-A1K
• incl. metrischem Schraubensatz und O-Ring including metric bolts and o-ring	AFS-...ST-A1K-M	AFX-...ST-A1K-MX
• incl. UNC Schraubensatz und O-Ring including unc bolts and o-ring	AFS-...ST-A1K-U	AFX-...ST-A1K-UX
• incl. metrischem Schraubensatz, O-Ring und Messanschluss including metric bolts, o-ring and test coupling	AFS-...ST-A1K-MM	AFX-...ST-A1K-MM
• incl. UNC Schraubensatz, O-Ring und Messanschluss including unc bolts, o-ring and test coupling	AFS-...ST-A1K-UM	AFX-...ST-A1K-UM

maximaler Betriebsdruck maximum recommended working pressure	S.A.E. Baugröße nominal flange size	Typ type	Abmessungen dimensions										Schrauben bolts		Gewicht weight	
			A	B	C	D	E	F	G	H	L	Mess-anschluss	M	kg		
kg/cm ²	inch															
Schraube Festigkeitskl. 10.9	Standarddruckreihe / Standard pressure											metr.	unc.			
280	1 ¼"	AFS 104 ST-A1K	42,8	32,0	58,7	79	30,2	68	41	21	11,5	G1/8"	M 10x40	7/16 x 1 ½	0,66	
210	1 ½"	AFS 106 ST-A1K	48,6	38,0	69,9	93	35,7	78	44	25	13,5	G1/8"	M 12x45	½ x 1 ¾	1,05	
210	2"	AFS 108 ST-A1K	61,0	51,0	77,8	102	42,9	90	45	25	13,5	G1/8"	M 12x45	½ x 1 ¾	1,19	
175	2 ½"	AFS 110 ST-A1K	77,0	63,0	88,9	114	50,8	105	50	25	13,5	G1/8"	M 12x45	½ x 1 ¾	1,40	
160	3"	AFS 112 ST-A1K	92,0	73,0	106,4	134	61,9	124	50	27	17,5	G1/8"	M 16x50	5/8 x 2	2,15	
35	3 ½"	AFS 114 ST-A1K	103,0	89,0	120,7	152	69,9	136	48	27	17,5	G1/8"	M 16x50	5/8 x 2	2,40	
35	4"	AFS 116 ST-A1K	115,5	99,0	130,2	162	77,8	146	48	27	17,5	G1/8"	M 16x50	5/8 x 2	2,85	
35	5"	AFS 118 ST-A1K	142,0	120,0	152,4	184	92,1	180	50	28	17,5	G1/8"	M 16x55	5/8 x 2	5,20	

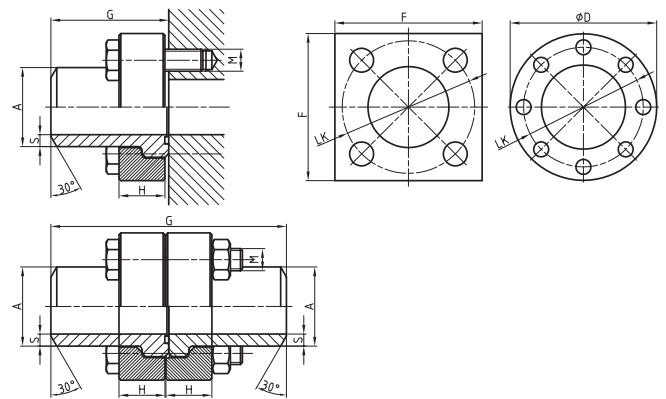
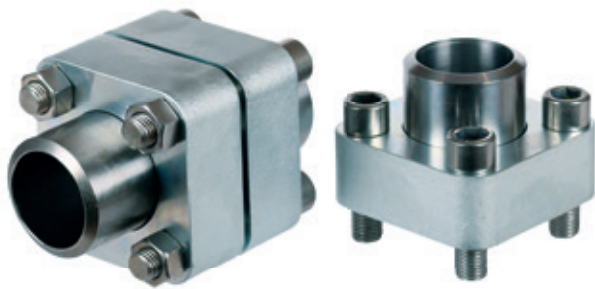

Bestellbezeichnung: ordering code:	S355J2^{*1} C45
• Anschweißflansch butt weld flange	VKA 32-.../AxSM
• Flanschkupplung butt weld flange-coupling	VKK 28-.../AxSM

maximaler Betriebsdruck maximum recommended working pressure kg/cm ²	DN DN	Typ type	Abmessungen dimensions						Schrauben bolts M	O-Ring o-ring	Gewicht weight kg
			AxS	LK	F	D	H	G			
Anschweißflansch / butt weld flange											
160	12	VKA 32-12/...	16x2	44	50	–	19	43	4 x M10 x 35	16,3 x 2,4	0,40
160	16	VKA 32-16/...	20x2,5	54	60	–	19	50	4 x M10 x 35	25,3 x 2,4	0,65
160	20	VKA 32-20/...	25x3	54	60	–	19	50	4 x M10 x 35	25,3 x 2,4	0,70
160	25	VKA 32-25/...	30x4	64	70	–	19	56	4 x M12 x 35	29,8 x 2,6	0,90
160	32	VKA 32-32/...	38x5	72	80	–	24	64	4 x M12 x 40	34,5 x 2,6	1,40
160	40	VKA 32-40/...	48,3x5	80	90	–	29	68	4 x M16 x 50	46,0 x 3,0	2,00
160	50	VKA 32-50/...	60,3x6,3	98	100	–	38	80	4 x M16 x 60	53,3 x 5,33	3,00
160	65	VKA 32-65/...	76,1x7,1; 76,1x8	118	120	–	47	98	4 x M20 x 70	69,2 x 5,33	5,20
160	80	VKA 32-80/...	101,6x10; 101,6x8,8	175	180	–	58	135	4 x M30 x 90	100,0 x 6,0	16,50
160	100	VKA 32-100/...	114,3x11; 114,3x10	175	180	–	58	135	4 x M30 x 90	106,9 x 7,0	16,90
160	125	VKA 32-125/...	152,4x16; 139,7x10	200	–	245	69	150	8 x M24 x 100	132,7 x 7,0	26,95
160	150	VKA 32-150/...	177,8x17,5; 168,3x10	245	–	300	79	190	8 x M30 x 110	158,1 x 7,0	46,50
Flanschkupplung / butt weld flange-coupling											
160	12	VKK 28-12/...	16x2	44	50	–	19	86	4 x M10 x 55	16,3 x 2,4	0,75
160	16	VKK 28-16/...	20x2,5	54	60	–	19	100	4 x M10 x 60	25,3 x 2,4	1,15
160	20	VKK 28-20/...	25x3	54	60	–	19	100	4 x M10 x 60	25,3 x 2,4	1,20
160	25	VKK 28-25/...	30x4	64	70	–	19	112	4 x M12 x 60	29,8 x 2,6	1,70
160	32	VKK 28-32/...	38x5	72	80	–	24	128	4 x M12 x 70	34,5 x 2,6	2,65
160	40	VKK 28-40/...	48,3x5	80	90	–	29	136	4 x M16 x 80	46,0 x 3,0	3,80
160	50	VKK 28-50/...	60,3x6,3	98	100	–	38	160	4 x M16 x 100	53,3 x 5,33	5,90
160	65	VKK 28-65/...	76,1x7,1; 76,1x8	118	120	–	47	196	4 x M20 x 120	69,2 x 5,33	9,90
160	80	VKK 28-80/...	101,6x10; 101,6x8,8	175	180	–	58	270	4 x M30 x 150	100,0 x 6,0	31,65
160	100	VKK 28-100/...	114,3x11; 114,3x10	175	180	–	58	270	4 x M30 x 150	106,9 x 7,0	32,15
160	125	VKK 28-125/...	152,4x16; 139,7x10	200	–	245	69	300	8 x M24 x 170	132,7 x 7,0	53,60
160	150	VKK 28-150/...	177,8x17,5; 168,3x10	245	–	300	79	380	8 x M30 x 200	158,1 x 7,0	92,75

*1 oder vergleichbare Güte / or comparable material

Ausführung: Schweißformen nach DIN 2559, Material: Vierkant S355J2/C45, Stutzen S355J2, auch in 1.4404 lieferbar /
Type: Welding gap form to DIN 2559, Material: Square S355J2/C45, Insert S355J2, also available in 1.4404

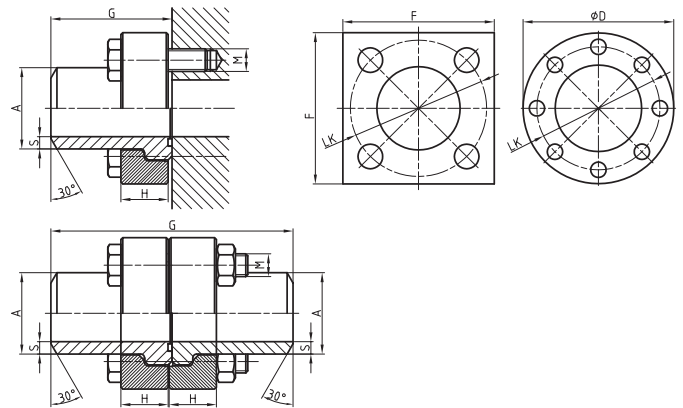
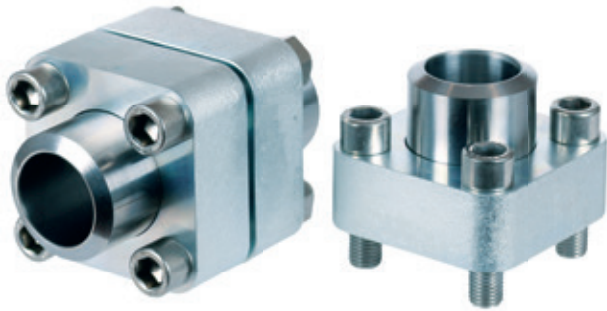

Bestellbezeichnung: ordering code:	S355J2^{*1} C45
• Anschweißflansch butt weld flange	VKA 33-.../AxSM
• Flanschkupplung butt weld flange-coupling	VKK 29-.../AxSM

maximaler Betriebsdruck maximum recommended working pressure	DN DN	Typ type	Abmessungen dimensions						Schrauben bolts	O-Ring o-ring	Gewicht weight
			AxS	LK	F	D	H	G			
kg/cm ²											
Anschweißflansch / butt weld flange											
250	10	VKA 33-10/...	17,2x3,6	44	50	–	20	43	4 x M10 x 35	16,3 x 2,4	0,44
250	16	VKA 33-16/...	21,3x2,6	54	60	–	20	50	4 x M10 x 35	25,3 x 2,4	0,71
250	20	VKA 33-20/...	26,9x3,6	64	70	–	20	56	4 x M12 x 35	29,8 x 2,6	0,90
250	25	VKA 33-25/...	33,7x4,5	72	80	–	25	64	4 x M12 x 40	34,5 x 2,6	1,40
250	32	VKA 33-32/...	42,4x5,6	80	90	–	30	68	4 x M16 x 50	43,0 x 3,0	2,10
250	40	VKA 33-40/...	60,3x8	98	100	–	38	80	4 x M16 x 60	53,3 x 5,33	3,10
250	50	VKA 33-50/...	76,1x10	118	120	–	47	98	4 x M20 x 70	61,0 x 5,0	5,40
250	65	VKA 33-65/...	88,9x11 88,9x10 ; 88,9x12,5	145	150	–	48	109	4 x M24 x 75	75,0 x 5,0	9,00
250	80	VKA 33-80/...	101,6x12,5 101,6x14,2 ; 114,3x12,5	175	180	–	58	135	4 x M30 x 90	88,0 x 6,0	16,90
250	100	VKA 33-100/...	139,7x17,5	200	–	245	70	150	8 x M24 x 100	115,0 x 6,0	27,85
250	125	VKA 33-125/...	168,3x20	245	–	300	80	190	8 x M30 x 110	148,0 x 7,0	47,70
250	150	VKA 33-150/...	193,7x25	290	–	355	90	190	8 x M36 x 130	183,5 x 7,0	53,20
Flanschkupplung / butt weld flange-coupling											
250	10	VKK 29-10/...	17,2x3,6	44	50	–	20	86	4 x M10 x 55	16,3 x 2,4	0,80
250	16	VKK 29-16/...	21,3x2,6	54	60	–	20	100	4 x M10 x 60	25,3 x 2,4	1,22
250	20	VKK 29-20/...	26,9x3,6	64	70	–	20	112	4 x M12 x 60	29,8 x 2,6	1,70
250	25	VKK 29-25/...	33,7x4,5	72	80	–	25	128	4 x M12 x 70	34,5 x 2,6	2,70
250	32	VKK 29-32/...	42,4x5,6	80	90	–	30	136	4 x M16 x 80	43,0 x 3,0	4,00
250	40	VKK 29-40/...	60,3x8	98	100	–	38	160	4 x M16 x 100	53,3 x 5,33	6,00
250	50	VKK 29-50/...	76,1x10	118	120	–	47	196	4 x M20 x 120	61,0 x 5,0	10,30
250	65	VKK 29-65/...	88,9x11 88,9x10 ; 88,9x12,5	145	150	–	48	218	4 x M24 x 130	75,0 x 5,0	17,45
250	80	VKK 29-80/...	101,6x12,5 101,6x14,2 ; 114,3x12,5	175	180	–	58	270	4 x M30 x 150	88,0 x 6,0	32,60
250	100	VKK 29-100/...	139,7x17,5	200	–	245	70	300	8 x M24 x 170	115,0 x 6,0	54,00
250	125	VKK 29-125/...	168,3x20	245	–	300	80	380	8 x M30 x 200	148,0 x 7,0	90,00
250	150	VKK 29-150/...	193,7x25	290	–	355	90	380	8 x M36 x 220	183,5 x 7,0	105,00

Ausführung: Schweißfugenform nach DIN 2559, Material: Vierkant S355J2/C45, Stutzen S355J2, auch in 1.4404 lieferbar / Type: Welding gap form to DIN 2559,

Material: Square S355J2/C45, Insert S355J2, also available in 1.4404

*1 oder vergleichbare Güte / or comparable material

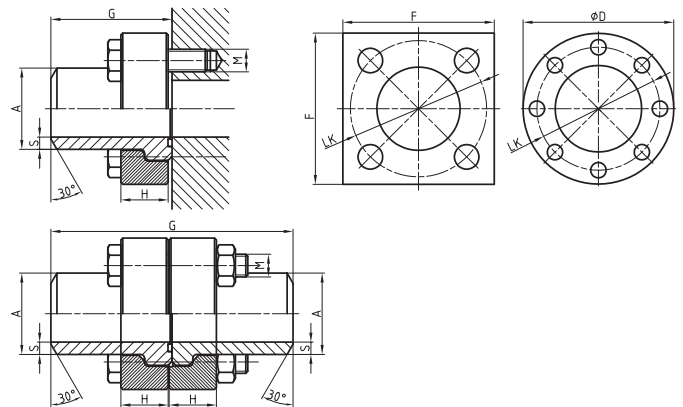
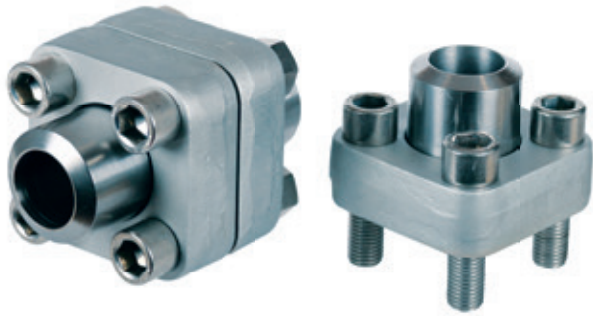

Bestellbezeichnung: ordering code:	S355J2^{*1} C45
• Anschweißflansch butt weld flange	VKA 34-.../AxSM
• Flanschkupplung butt weld flange-coupling	VKK 30-.../AxSM

maximaler Betriebsdruck maximum recommended working pressure kg/cm ²	DN DN	Typ type	Abmessungen dimensions						Schrauben bolts M	O-Ring o-ring	Gewicht weight kg
			AxS	LK	F	D	H	G			
Anschweißflansch / butt weld flange											
315	10	VKA 34-10/...	17,2x3,6	44	50	–	20	43	4 x M10 x 35	16,3 x 2,40	0,45
315	16	VKA 34-16/...	26,9x4,5	54	60	–	20	50	4 x M10 x 35	25,5 x 2,40	0,70
315	20	VKA 34-20/...	33,7x5,6	64	70	–	20	56	4 x M12 x 35	29,8 x 2,60	0,90
315	25	VKA 34-25/...	42,7x7,1	72	80	–	25	64	4 x M12 x 40	34,5 x 2,60	1,45
315	32	VKA 34-32/...	48,3x8,0; 48,3x6	80	90	–	30	68	4 x M16 x 50	43,0 x 3,00	2,20
315	40	VKA 34-40/...	60,3x10; 60,3x11	98	100	–	38	80	4 x M16 x 60	53,3 x 5,33	3,20
315	50	VKA 34-50/...	76,1x12,5	118	120	–	47	98	4 x M20 x 70	61,0 x 5,00	5,60
315	65	VKA 34-65/...	88,9x14,2	145	150	–	48	109	4 x M24 x 75	75,0 x 5,00	9,50
315	80	VKA 34-80/...	114,3x17,5; 114,3x12,5; 114,3x14,2; 114,3x16; 101,6x16; 101,6x20	175	180	–	58	135	4 x M30 x 90	88,0 x 6,00	17,60
315	100	VKA 34-100/...	152,5x28; 139,7x25	200	–	245	70	150	8 x M24 x 100	115,0 x 6,00	29,30
315	125	VKA 34-125/...	177,8x30; 168,3x25	245	–	300	80	190	8 x M30 x 110	148,0 x 7,00	48,20
315	150	VKA 34-150/...	219,1x36	290	–	355	90	190	8 x M36 x 130	183,5 x 7,00	55,10
Flanschkupplung / butt weld flange-coupling											
315	10	VKK 30-12/...	17,2x3,6	44	50	–	20	86	4 x M10 x 55	16,3 x 2,40	0,81
315	16	VKK 30-16/...	26,9x4,5	54	60	–	20	100	4 x M10 x 60	25,3 x 2,40	1,21
315	20	VKK 30-20/...	33,7x5,6	64	70	–	20	112	4 x M12 x 60	29,8 x 2,60	1,70
315	25	VKK 30-25/...	42,7x7,1	72	80	–	25	128	4 x M12 x 70	34,5 x 2,60	2,70
315	32	VKK 30-32/...	48,3x8,0; 48,3x6	80	90	–	30	136	4 x M16 x 80	43,0 x 3,00	4,15
315	40	VKK 30-40/...	60,3x10; 60,3x11	98	100	–	38	160	4 x M16 x 100	53,3 x 5,33	6,25
315	50	VKK 30-50/...	76,1x12,5	118	120	–	47	196	4 x M20 x 120	61,0 x 5,00	10,80
315	65	VKK 30-65/...	88,9x14,2	145	150	–	48	218	4 x M24 x 130	75,0 x 5,00	18,35
315	80	VKK 30-80/...	114,3x17,5; 114,3x12,5; 114,3x14,2; 114,3x16; 101,6x16; 101,6x20	175	180	–	58	270	4 x M30 x 150	88,0 x 6,00	33,80
315	100	VKK 30-100/...	152,5x28; 139,7x25	200	–	245	70	300	8 x M24 x 170	115,0 x 6,00	57,20
315	125	VKK 30-125/...	177,8x30; 168,3x25	245	–	300	80	380	8 x M30 x 200	148,0 x 7,00	95,00
315	150	VKK 30-150/...	219,1x36	290	–	355	90	380	8 x M36 x 220	183,5 x 7,00	109,20

Ausführung: Schweißfugenform nach DIN 2559, Material: Vierkant S355J2/C45, Stutzen S355J2, auch in 1.4404 lieferbar / Type: Welding gap form to DIN 2559, Material: Square S355J2/C45, Insert S355J2, also available in 1.4404

*1 oder vergleichbare Güte / or comparable material

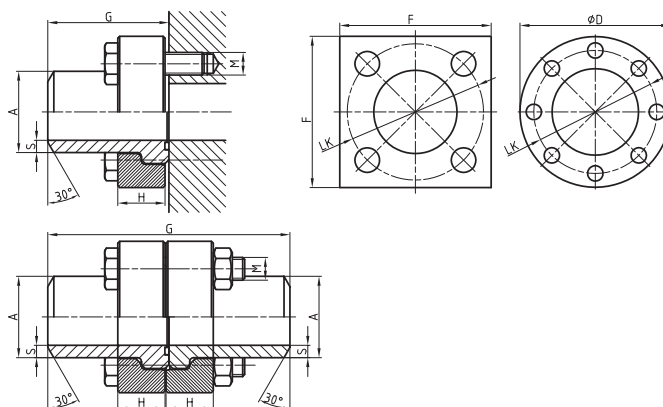

Bestellbezeichnung: ordering code:	S355J2^{*1} C45
• Anschweißflansch butt weld flange	VKA 43-.../AxSM
• Flanschkupplung butt weld flange-coupling	VKK 41-.../AxSM

maximaler Betriebsdruck maximum recommended working pressure	DN DN	Typ type	Abmessungen dimensions						Schrauben bolts	O-Ring o-ring	Gewicht weight
			AxS	LK	F	D	H	G			
kg/cm ²								M		kg	
Anschweißflansch / butt weld flange											
400	10	VKA 43-10/...	17,2x3,6	44	50	–	20	43	4 x M10 x 35	16,3 x 2,40	0,45
400	16	VKA 43-16/...	26,9x5,6	54	60	–	20	50	4 x M10 x 35	25,3 x 2,40	0,70
400	20	VKA 43-20/...	33,7x6,3	64	70	–	20	56	4 x M12 x 35	29,8 x 2,60	0,90
400	25	VKA 43-25/...	42,7x8,0	72	80	–	25	64	4 x M12 x 40	34,5 x 2,60	1,45
400	32	VKA 43-32/...	60,3x12,5	98	100	–	38	80	4 x M16 x 60	53,3 x 5,33	2,20
400	40	VKA 43-40/...	70,0x14,2	118	120	–	47	98	4 x M20 x 70	61,0 x 5,00	3,20
400	50	VKA 43-50/...	88,9x17,5	145	150	–	48	109	4 x M24 x 75	75,0 x 5,00	5,60
400	65	VKA 43-65/...	101,6x20,0	175	180	–	58	135	4 x M30 x 90	88,0 x 6,00	9,50
400	80	VKA 43-80/...	139,7x28,0	200	–	245	70	150	8 x M24 x 100	115,0 x 6,00	17,60
400	100	VKA 43-100/...	168,3x32,0	245	–	300	80	190	8 x M30 x 110	148,0 x 7,00	29,30
400	125	VKA 43-125/...	219,1x45,0	290	–	355	90	190	8 x M36 x 130	183,5 x 7,00	48,20
Flanschkupplung / butt weld flange-coupling											
400	10	VKK 41-10/...	17,2x3,6	44	50	–	20	86	4 x M10 x 55	16,3 x 2,40	0,81
400	16	VKK 41-16/...	26,9x5,6	54	60	–	20	100	4 x M10 x 60	25,3 x 2,40	1,21
400	20	VKK 41-20/...	33,7x6,3	64	70	–	20	112	4 x M12 x 60	29,8 x 2,60	1,70
400	25	VKK 41-25/...	42,7x8,0	72	80	–	25	128	4 x M12 x 70	34,5 x 2,60	2,70
400	32	VKK 41-32/...	60,3x12,5	98	100	–	38	160	4 x M16 x 100	53,3 x 5,33	4,15
400	40	VKK 41-40/...	70,0x14,2	118	120	–	45	196	4 x M20 x 120	61,0 x 5,00	6,25
400	50	VKK 41-50/...	88,9x17,5	145	150	–	48	218	4 x M24 x 130	75,0 x 5,00	10,80
400	65	VKK 41-65/...	101,6x20,0	175	180	–	58	270	4 x M30 x 150	88,0 x 6,00	18,35
400	80	VKK 41-80/...	139,7x28,0	200	–	245	70	300	8 x M24 x 170	115,0 x 6,00	33,80
400	100	VKK 41-100/...	168,3x32,0	245	–	300	80	380	8 x M30 x 200	148,0 x 7,00	57,20
400	125	VKK 41-125/...	219,1x45,0	290	–	355	90	380	8 x M36 x 220	183,5 x 7,00	95,00

*1 oder vergleichbare Güte / or comparable material

Ausführung: Schweißfugenform nach DIN 2559, Material: Vierkant S355J2/C45, Stutzen S355J2, auch in 1.4404 lieferbar /
Type: Welding gap form to DIN 2559, Material: Square S355J2/C45, Insert S355J2, also available in 1.4404

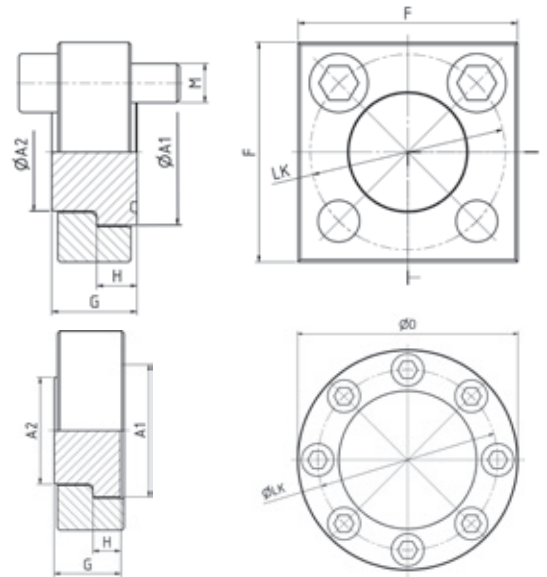

Bestellbezeichnung: ordering code:	S355J2^{*1}
<ul style="list-style-type: none"> Blindflansch mit Nut (Blindstopfen mit Nut inkl. Vierkant- bzw. Rundflansch, O-Ring und Schrauben) <i>flange plug with o-ring groove (flange plug including square or round flange respectively, o-ring and bolts)</i> 	VKB-... -160KM
<ul style="list-style-type: none"> Blindflansch ohne Nut (Blindstopfen ohne Nut inkl. Vierkant- bzw. Rundflansch) <i>flange plug without o-ring groove (flange plug including square or round flange respectively)</i> 	G-VKB-... -160K

maximaler Betriebsdruck <i>maximum recommended working pressure</i>	DN <i>DN</i>	Typ <i>type</i>	Abmessungen <i>dimensions</i>							Schrauben <i>bolts</i>	O-Ring <i>o-ring</i>	Gewicht (nur Blind-stopfen) <i>weight (flange plug only)</i>
			A1	A2	LK	F	D	G	H			
Blindflansch mit Nut / flange plug with o-ring groove												
160	12	VKB-12-160KM	28,0	17,5	44,0	50,0	–	25,0	11,5	4 x M10x35	16,3x2,4	–
160	16	VKB-16-160KM	38,0	27,0	54,0	60,0	–	25,0	11,5	4 x M10x35	25,3x2,4	–
160	20	VKB-20-160KM										
160	25	VKB-25-160KM	46,0	34,0	64,0	70,0	–	25,0	12,5	4 x M12x35	29,8x2,6	–
160	32	VKB-32-160KM	54,5	43,0	72,0	80,0	–	30,0	14,5	4 x M12x40	34,5x2,6	–
160	40	VKB-40-160KM	60,0	48,3	80,0	90,0	–	35,0	16,5	4 x M16x50	43,0x3,0	–
160	50	VKB-50-160KM	76,0	60,3	98,0	100,0	–	43,0	24,0	4 x M16x60	53,3x5,33	–
160	65	VKB-65-160KM	92,0	77,0	118,0	120,0	–	52,0	25,0	4 x M20x70	61,0x5,0	–
160	80	VKB-80-160KM	135,0	114,5	175,0	180,0	–	63,0	33,0	4 x M30x90	88,0x6,0	–
160	100	VKB-100-160KM										
160	125	VKB-125-160KM	168,0	153,0	200,0	–	245,0	75,0	39,0	8 x M24x100	115,0x6,0	–
160	150	VKB-150-160KM	210,0	178,0	245,0	–	300,0	90,0	45,0	8 x M30x110	148,0x7,0	–
Blindflansch ohne Nut / flange plug without o-ring groove												
160	12	G-VKB-12-160K	28,0	17,5	44,0	50,0	–	20,0	8,0	–	–	–
160	16	G-VKB-16-160K	38,0	27,0	54,0	60,0	–	20,0	8,0	–	–	–
160	20	G-VKB-20-160K										
160	25	G-VKB-25-160K	46,0	34,0	64,0	70,0	–	20,0	9,0	–	–	–
160	32	G-VKB-32-160K	54,5	43,0	72,0	80,0	–	25,0	11,0	–	–	–
160	40	G-VKB-40-160K	60,0	48,3	80,0	90,0	–	30,0	12,5	–	–	–
160	50	G-VKB-50-160K	76,0	60,3	98,0	100,0	–	38,0	18,0	–	–	–
160	65	G-VKB-65-160K	92,0	77,0	118,0	120,0	–	47,0	18,0	–	–	–
160	80	G-VKB-80-160K	135,0	114,5	175,0	180,0	–	58,0	24,0	–	–	–
160	100	G-VKB-100-160K										
160	125	G-VKB-125-160K	168,0	153,0	200,0	–	245,0	70,0	33,0	–	–	–
160	150	G-VKB-150-160K	210,0	178,0	245,0	–	300,0	82,0	37,0	–	–	–

*1 oder vergleichbare Güte (auch in 1.4404 lieferbar) / or comparable material (also available in 1.4404)

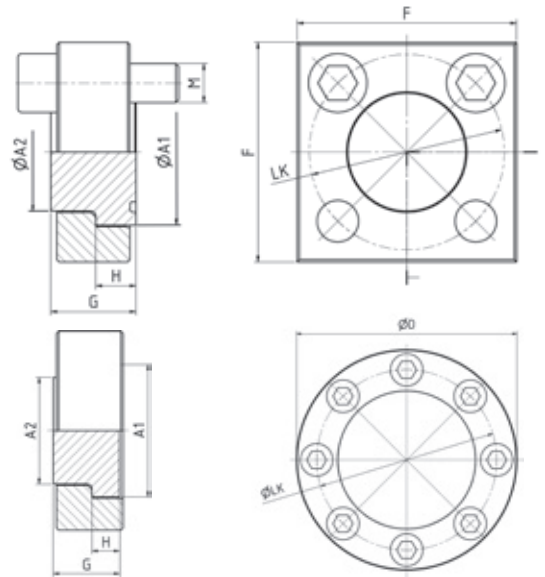

Bestellbezeichnung: ordering code:	S355J2^{*1}
<ul style="list-style-type: none"> • nur Blindstopfen mit Nut flange plug with o-ring groove only • nur Blindstopfen ohne Nut flange plug without o-ring groove only • Blindflansch mit Nut (Blindstopfen mit Nut inkl. Vierkant- bzw. Rundflansch, O-Ring und Schrauben) flange plug with o-ring groove (flange plug including square or round flange respectively, o-ring and bolts) • Blindflansch ohne Nut (Blindstopfen ohne Nut inkl. Vierkant- bzw. Rundflansch) flange plug without o-ring groove (flange plug including square or round flange respectively) 	VKB-... G-VKB-... VKB-... KM G-VKB-... K

maximaler Betriebsdruck maximum recommended working pressure	DN DN	Typ type	Abmessungen dimensions							Schrauben bolts	O-Ring o-ring	Gewicht (nur Blindstopfen) weight (flange plug only)
			A1	A2	LK	F	D	G	H			
Blindflansch mit Nut / flange plug with o-ring groove												
kg/cm ²												
250/315	10	VKB 10	28,0	17,5	44,0	50,0	–	25,0	11,5	4 x M10x35	16,3 x 2,40	0,08
250/315	16	VKB 16	38,0	27,0	54,0	60,0	–	25,0	11,5	4 x M10x35	25,3 x 2,40	0,16
250/315	20	VKB 20	46,0	34,0	64,0	70,0	–	25,0	12,5	4 x M12x35	29,8 x 2,60	0,25
250/315	25	VKB 25	54,5	43,0	72,0	80,0	–	30,0	14,5	4 x M12x40	34,5 x 2,60	0,44
250/315	32	VKB 32	60,0	48,3	80,0	90,0	–	35,0	16,5	4 x M16x50	43,0 x 3,00	0,62
250/315	40	VKB 40	76,0	60,3	98,0	100,0	–	43,0	24,0	4 x M16x60	53,3 x 5,33	1,24
250/315	50	VKB 50	92,0	77,0	118,0	120,0	–	52,0	25,0	4 x M20x70	61,0 x 5,00	2,25
250/315	65	VKB 65	116,0	89,0	145,0	150,0	–	53,0	29,0	4 x M24x75	75,0 x 5,00	3,52
250/315	80	VKB 80	135,0	114,5	175,0	180,0	–	63,0	33,0	4 x M30x90	88,0 x 6,00	6,04
250/315	100	VKB 100	168,0	153,0	200,0	–	245,0	75,0	39,0	8 x M24x100	115,0 x 6,00	11,86
250/315	125	VKB 125	210,0	178,0	245,0	–	300,0	90,0	45,0	8 x M30x110	148,0 x 7,00	20,82
250/315	150	VKB 150	245,0	219,1	290,0	–	355,0	90,0	50,0	8 x M36x130	183,5 x 7,00	30,01
Blindflansch ohne Nut / flange plug without o-ring groove												
250/315	10	G-VKB 10	28,0	17,5	44,0	50,0	–	20,0	8,0	–	–	0,06
250/315	16	G-VKB 16	38,0	27,0	54,0	60,0	–	20,0	8,0	–	–	0,13
250/315	20	G-VKB 20	46,0	34,0	64,0	70,0	–	20,0	9,0	–	–	0,20
250/315	25	G-VKB 25	54,5	43,0	72,0	80,0	–	25,0	11,0	–	–	0,36
250/315	32	G-VKB 32	60,0	48,3	80,0	90,0	–	30,0	12,5	–	–	0,53
250/315	40	G-VKB 40	76,0	60,3	98,0	100,0	–	38,0	18,0	–	–	1,08
250/315	50	G-VKB 50	92,0	77,0	118,0	120,0	–	47,0	18,0	–	–	2,00
250/315	65	G-VKB 65	116,0	89,0	145,0	150,0	–	48,0	21,0	–	–	3,06
250/315	80	G-VKB 80	135,0	114,5	175,0	180,0	–	58,0	24,0	–	–	5,45
250/315	100	G-VKB 100	168,0	153,0	200,0	–	245,0	70,0	33,0	–	–	11,09
250/315	125	G-VKB 125	210,0	178,0	245,0	–	300,0	82,0	37,0	–	–	18,85
250/315	150	G-VKB 150	245,0	219,1	290,0	–	355,0	85,0	42,0	–	–	28,25

*1 oder vergleichbare Güte (auch in 1.4404 lieferbar) / or comparable material (also available in 1.4404)

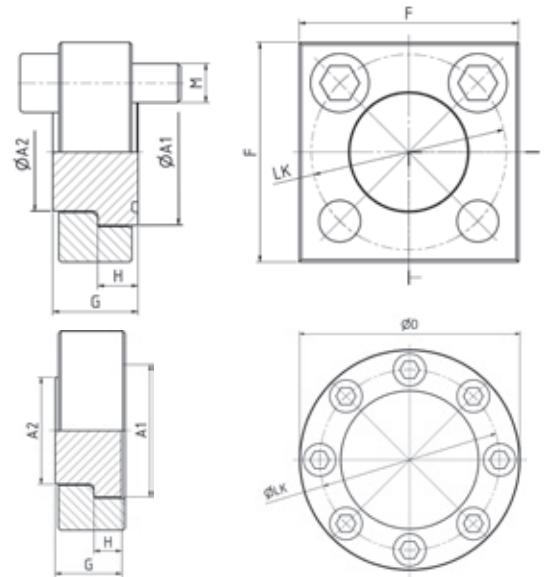

Bestellbezeichnung: ordering code:	S355J2^{*1}
<ul style="list-style-type: none"> Blindflansch mit Nut (Blindstopfen mit Nut inkl. Vierkant- bzw. Rundflansch, O-Ring und Schrauben) flange plug with o-ring groove (flange plug including square or round flange respectively, o-ring and bolts) 	VKB-... -400KM
<ul style="list-style-type: none"> Blindflansch ohne Nut (Blindstopfen ohne Nut inkl. Vierkant- bzw. Rundflansch) flange plug without o-ring groove (flange plug including square or round flange respectively) 	G-VKB-... -400K

maximaler Betriebsdruck maximum recommended working pressure	DN DN	Typ type	Abmessungen dimensions							Schrauben bolts	O-Ring o-ring	Gewicht (nur Blindstopfen) weight (flange plug only)
			A1	A2	LK	F	D	G	H			
Blindflansch mit Nut / flange plug with o-ring groove												
400	10	VKB-10-400KM	28,0	17,5	44,0	50,0	–	25,0	11,5	4 x M10x35	16,3x2,4	–
400	16	VKB-16-400KM	38,0	27,0	54,0	60,0	–	25,0	11,5	4 x M10x35	25,3x2,4	–
400	20	VKB-20-400KM	46,0	34,0	64,0	70,0	–	25,0	12,5	4 x M12x35	29,8x2,6	–
400	25	VKB-25-400KM	54,5	43,0	72,0	80,0	–	30,0	14,5	4 x M12x40	34,5x2,6	–
400	32	VKB-32-400KM	76,0	60,3	98,0	100,0	–	43,0	24,0	4 x M16x60	53,3x5,33	–
400	40	VKB-40-400KM	92,0	77,0	118,0	120,0	–	52,0	25,0	4 x M20x70	61,0x5,0	–
400	50	VKB-50-400KM	116,0	89,0	145,0	150,0	–	53,0	29,0	4 x M24x75	75,0x5,0	–
400	65	VKB-65-400KM	135,0	114,5	175,0	180,0	–	63,0	33,0	4 x M30x90	88,0x6,0	–
400	80	VKB-80-400KM	168,0	153,0	200,0	–	245,0	75,0	39,0	8 x M24x100	115,0x6,0	–
400	100	VKB-100-400KM	210,0	178,0	245,0	–	300,0	90,0	45,0	8 x M30x110	148,0x7,0	–
400	125	VKB-125-400KM	245,0	219,1	290,0	–	355,0	90,0	50,0	8 x M36x130	183,5x7,0	–
Blindflansch ohne Nut / flange plug without o-ring groove												
400	10	G-VKB-10-400K	28,0	17,5	44,0	50,0	–	20,0	8,0	–	–	–
400	16	G-VKB-16-400K	38,0	27,0	54,0	60,0	–	20,0	8,0	–	–	–
400	20	G-VKB-20-400K	46,0	34,0	64,0	70,0	–	20,0	9,0	–	–	–
400	25	G-VKB-25-400K	54,5	43,0	72,0	80,0	–	25,0	11,0	–	–	–
400	32	G-VKB-32-400K	76,0	60,3	98,0	100,0	–	38,0	18,0	–	–	–
400	40	G-VKB-40-400K	92,0	77,0	118,0	120,0	–	47,0	18,0	–	–	–
400	50	G-VKB-50-400K	116,0	89,0	145,0	150,0	–	48,0	21,0	–	–	–
400	65	G-VKB-65-400K	135,0	114,5	175,0	180,0	–	58,0	24,0	–	–	–
400	80	G-VKB-80-400K	168,0	153,0	200,0	–	245,0	70,0	33,0	–	–	–
400	100	G-VKB-100-400K	210,0	178,0	245,0	–	300,0	82,0	37,0	–	–	–
400	125	G-VKB-125-400K	245,0	219,1	290,0	–	355,0	85,0	42,0	–	–	–

*1 oder vergleichbare Güte (auch in 1.4404 lieferbar) / or comparable material (also available in 1.4404)

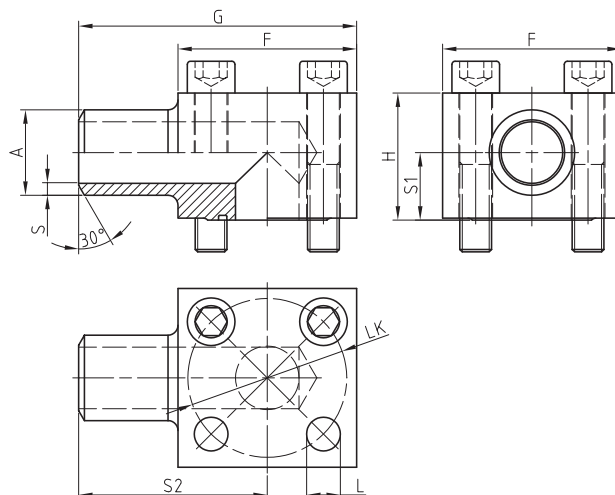
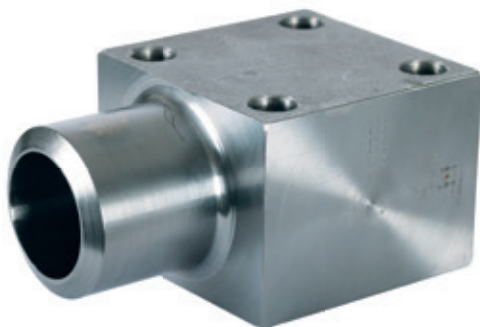

Bestellbezeichnung: ordering code:	S355J2^{*1} C15
• nur Winkelflansch elbow only	VKW-...
• incl. Schraubensatz und O-Ring including bolts and o-ring	VKW-...M

maximaler Betriebsdruck maximum recommended working pressure	DN DN	Typ type	Abmessungen dimensions									Schrauben bolts	O-Ring o-ring	Gewicht weight
			AxS	LK	F	S1	S2	H	G	L	M			
90° Winkelflansch / 90° elbow														
250	10	VKW 10	17,2x3,6	44	50	17	55	29	80	11	4/M10x40	16,3 x 2,40	–	
250	16	VKW 16	21,3x2,6	54	60	23	65	41	95	11	4/M10x45	25,3 x 2,40	–	
250	20	VKW 20	26,9x3,6	64	70	26	75	47	110	13	4/M12x60	29,8 x 2,60	–	
250	25	VKW 25	33,7x4,5	72	80	30	90	56	130	13	4/M12x65	34,5 x 2,60	–	
250	32	VKW 32	42,4x5,6	80	90	35	95	64	140	17	4/M16x80	43,0 x 3,00	3,2	
250	40	VKW 40	60,3x8 ; 60,3x10	98	100	40	105	76	155	17	4/M16x100	53,3 x 5,33	4,9/5,1	
250	50	VKW 50	76,1x10 ; 76,1x12,5	118	120	53	115	100	175	22	4/M20x125	61,0 x 5,00	8,2/9,1	
250	65	VKW 65	88,9x11 ; 88,9x14,2	145	150	64	125	120	200	25	4/M24x150	75,0 x 5,00	16,1/16,8	
250	80	VKW 80	114,3x12,5 101,6x14,2 ; 114,3x17,5	175	180	73	130	140	220	32	4/M30x180	88,0 x 6,00	24,9 26,3/26,8	

*1 oder vergleichbare Güte (auch in 1.4404 lieferbar) / or comparable material (also available in 1.4404)

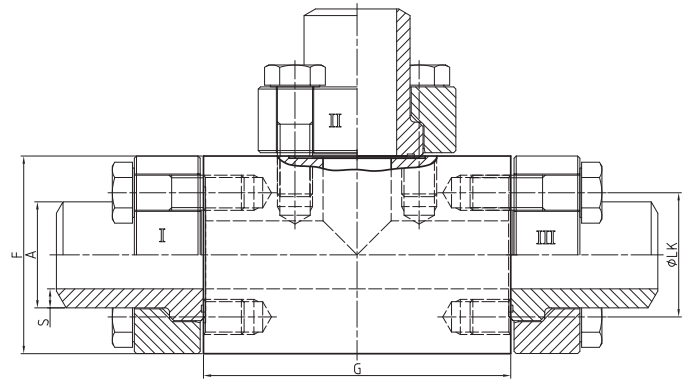

Bestellbezeichnung: ordering code:	S355J2^{*1}	1.4404^{*1} 316L
• nur T-Flanschverbinder T-flange connector only	VKV-...	VKV-X-...
• incl. Flansch, Schrauben und O-Ring including flange, bolts and o-ring	VKV-...KM	VKV-X-...KMX

* Der angeführte maximale Betriebsdruck ist bezogen auf den Flansch! Der tatsächliche Betriebsdruck wird bestimmt durch das Rohr (Wandstärke) sowie die Güte des Rohres!
The maximum recommended working pressure is based on the flange. The working pressure of the system is determined by the tube (thickness) and by the steel quality of the tube!

maximaler Betriebsdruck * maximum recommended working pressure	DN	Typ type	Abmessungen dimensions				Schrauben bolts	O-Ring o-ring	Gewicht weight
			AxS (I, II, III)	LK	F	G			
kg/cm ²							M		kg
T-Flanschverbinder / T-flange connector									
400	10	VKV 10	Abhängig von der Anwendung Dependent on use	44	50	100	12/M10x35	16,3 x 2,40	1,7
400	16	VKV 16		54	60	110	12/M10x35	25,3 x 2,40	-
400	20	VKV 20		64	70	115	12/M12x35	29,8 x 2,60	3,8
400	25	VKV 25		72	80	125	12/M12x40	34,5 x 2,60	5,4
400	32	VKV 32		80	90	140	12/M16x50	43,0 x 3,00	7,4
400	40	VKV 40		98	100	160	12/M16x60	53,3 x 5,33	9,8
400	50	VKV 50		118	120	180	12/M20x70	61,0 x 5,00	15,4
400	65	VKV 65		145	150	200	12/M24x75	75,0 x 5,00	27,1
400	80	VKV 80		175	180	240	12/M30x90	88,0 x 6,00	48,2

T-Flanschverbinder ist auch mit unterschiedlichen Abgängen bzw. Rohrabmessungen lieferbar. dimensions. Example: I = DN 25/33,7x4,5, II = DN 16/21,3x2,6, III = DN 20/29,9x3,6, Best.-Nr. VKV-25/33,7x4,5 – 20/29,9x3,6, Order no. VKV-25/33,7x4,5 – 16/21,3x2,6 – 20/26,9x3,6. 16/21,3x2,6 – 20/26,9x3,6 / T-flange connector can also be supplied with different sizes or different tube ^{*1} oder vergleichbare Güte / or comparable material

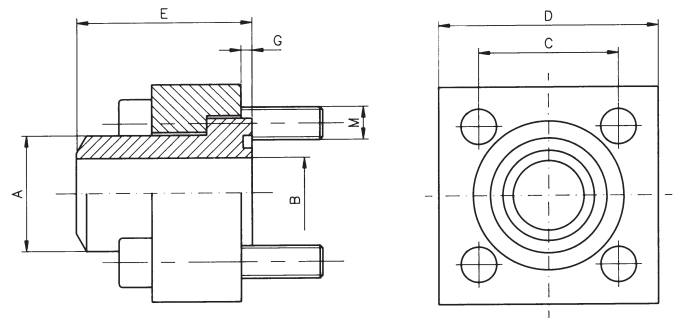

Bestellbezeichnung: ordering code:	S355J2^{*1}
• Anschweißflansch (incl. metrischem Schraubensatz und O-Ring) butt weld flange (including metric bolts and o-ring)	CET-...M

maximaler Betriebsdruck maximum recommended working pressure	S.A.E. Baugröße nominal flange size	Typ type	Abmessungen dimensions						Schrauben bolts	Gewicht weight
			A	B	C	D	E	G		
kg/cm ²	inch									kg
Nennndruck 250 bar / nominal pressure 250 bar										
250	3/8"	CET 38 ST 250	18	12,5	24,7	40	30	1,0	M 6x35	0,17
250	1/2"	CET 12 ST 250	22	15,0	29,7	45	30	1,0	M 8x30	0,22
250	3/4"	CET 34 ST 250	28	20,0	35,3	50	35	1,0	M 8x30	0,32
250	1"	CET 1 ST 250	35	25,0	43,8	65	40	1,0	M 10x35	0,63
250	1 1/4"	CET 114 ST 250	43	32,0	51,6	75	45	1,0	M 12x40	0,92
250	1 1/2"	CET 112 ST 250	50	38,0	60,0	85	50	1,0	M 14x45	1,34
250	2"	CET 2 ST 250	62	47,0	69,4	100	60	1,5	M 16x55	2,30
250	2 1/2"	CET 212 ST 250	76	58,0	83,4	120	70	1,5	M 20x60	4,00
250	3"	CET 3 ST 250	90	70,0	102,5	140	80	1,5	M 20x70	6,03
250	3 1/2"	CET 312 ST 250	102	80,0	102,5	140	90	1,5	M 20x90	7,56
250	4"	CET 4 ST 250	114	90,0	113,2	160	105	1,5	M 24x100	10,96
Nennndruck 400 bar / nominal pressure 400 bar										
400	3/8"	CET 38 ST 400	18	11,0	24,7	40	35	1,0	M 6x35	0,20
400	1/2"	CET 12 ST 400	22	14,0	29,7	45	40	1,0	M 8x30	0,31
400	3/4"	CET 34 ST 400	28	18,0	35,3	50	45	1,0	M 8x35	0,45
400	1"	CET 1 ST 400	35	22,0	43,8	65	50	1,0	M 10x40	0,83
400	1 1/4"	CET 114 ST 400	43	29,0	51,6	75	55	1,0	M 12x45	1,19
400	1 1/2"	CET 112 ST 400	51	35,0	60,0	85	60	1,0	M 14x55	1,80
400	2"	CET 2 ST 400	61	43,0	69,4	100	70	1,5	M 16x60	3,08
400	2 1/2"	CET 212 ST 400	80	53,0	83,4	120	80	1,5	M 20x70	5,14
400	3"	CET 3 ST 400	90	58,0	102,5	140	90	1,5	M 20x90	7,34
400	3 1/2"	CET 312 ST 400	102	63,0	102,5	140	90	1,5	M 20x90	8,09
400	4"	CET 4 ST 400	114	74,0	113,2	160	105	1,5	M 24x100	12,75

*1 oder vergleichbare Güte / or comparable material

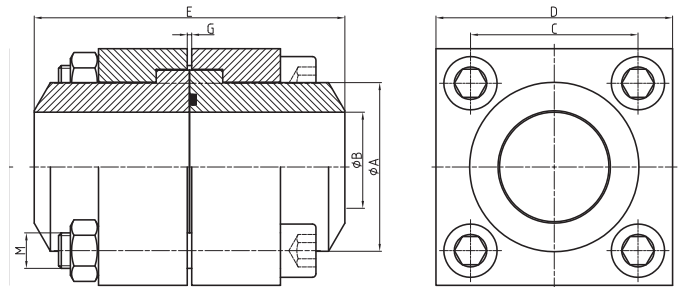

Bestellbezeichnung: ordering code:	S355J2^{*1}
• Flanschkupplung (incl. metrischem Schraubensatz und O-Ring) flange-coupling (including metric bolts and o-ring)	D-CET-...M

maximaler Betriebsdruck maximum recommended working pressure	S.A.E. Baugröße nominal flange size	Typ type	Abmessungen dimensions						Schrauben bolts	Gewicht weight
			A	B	C	D	E	G		
kg/cm ²	inch									kg
Nennndruck 250 bar / nominal pressure 250 bar										
250	3/8"	DCET 38 ST/250	18	12,5	24,7	40	60	2	M 6x45	0,42
250	1/2"	DCET 12 ST/250	22	15,0	29,7	45	60	2	M 8x45	0,52
250	3/4"	DCET 34 ST/250	28	20,0	35,3	50	70	2	M 8x45	0,68
250	1"	DCET 1 ST/250	35	25,0	43,8	65	80	2	M 10x50	1,30
250	1 1/4"	DCET 114 ST/250	43	32,0	51,6	75	90	2	M 12x60	1,98
250	1 1/2"	DCET 112 ST/250	50	38,0	60,0	85	100	2	M 14x70	2,79
250	2"	DCET 2 ST/250	62	47,0	69,4	100	120	3	M 16x90	4,67
250	2 1/2"	DCET 212 ST/250	76	58,0	83,4	120	140	3	M 20x100	7,96
250	3"	DCET 3 ST/250	90	70,0	102,5	140	160	3	M 20x110	11,80
250	3 1/2"	DCET 312 ST/250	102	80,0	102,5	140	180	3	M 20x130	14,10
250	4"	DCET 4 ST/250	114	90,0	113,2	160	210	3	M 24x150	21,60
Nennndruck 400 bar / nominal pressure 400 bar										
400	3/8"	DCET 38 ST/400	18	11,0	24,7	40	70	2	M 6x45	0,47
400	1/2"	DCET 12 ST/400	22	14,0	29,7	45	80	2	M 8x50	0,63
400	3/4"	DCET 34 ST/400	28	18,0	35,2	50	90	2	M 8x60	0,90
400	1"	DCET 1 ST/400	35	22,0	43,8	65	100	2	M 10x70	1,73
400	1 1/4"	DCET 114 ST/400	44	29,0	51,6	75	110	2	M 12x80	2,62
400	1 1/2"	DCET 112 ST/400	51	35,0	60,0	85	120	2	M 14x90	3,76
400	2"	DCET 2 ST/400	61	43,0	69,4	100	140	3	M 16x100	6,40
400	2 1/2"	DCET 212 ST/400	80	53,0	83,4	120	160	3	M 20x110	10,50
400	3"	DCET 3 ST/400	90	58,0	102,5	140	180	3	M 20x130	16,40
400	3 1/2"	DCET 312 ST/400	102	63,0	102,5	140	180	3	M 20x130	16,70
400	4"	DCET 4 ST/400	114	74,0	113,2	160	210	3	M 24x160	25,00

*1 oder vergleichbare Güte / or comparable material

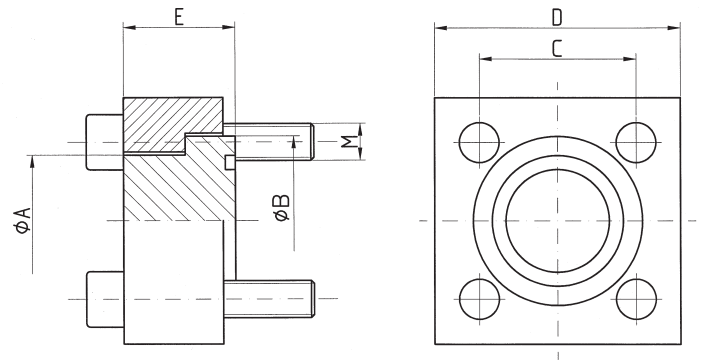

Bestellbezeichnung: ordering code:	S355J2^{*1}
• Blindflansch (incl. metrischem Schraubensatz und O-Ring) flange plug (including metric bolts and o-ring)	BS-...M

maximaler Betriebsdruck maximum recommended working pressure	S.A.E. Baugröße nominal flange size	Typ type	Abmessungen dimensions					Schrauben bolts	Gewicht weight
			A	B	C	D	E		
kg/cm ²	inch								
Nenndruck 250 bar / nominal pressure 250 bar									
250	3/8"	BS 38 ST 250	18,0	24,5	24,7	40	15	M 6x35	0,04
250	1/2"	BS 12 ST 250	24,0	30,2	29,7	45	16	M 8x30	0,07
250	3/4"	BS 34 ST 250	31,5	38,1	35,3	50	17	M 8x30	0,13
250	1"	BS 1 ST 250	38,0	44,4	43,8	65	19	M 10x35	0,19
250	1 1/4"	BS 114 ST 250	43,0	50,8	51,6	75	23	M 12x40	0,30
250	1 1/2"	BS 112 ST 250	50,0	60,3	60,0	85	26	M 14x45	0,46
250	2"	BS 2 ST 250	62,0	71,4	69,4	100	31	M 16x55	0,82
250	2 1/2"	BS 212 ST 250	76,0	87,2	83,4	120	37	M 20x60	1,44
250	3"	BS 3 ST 250	90,0	101,6	102,5	140	42	M 20x70	2,25
250	3 1/2"	BS 312 ST 250	102,0	119,0	102,5	140	54	M 20x90	3,90
250	4"	BS 4 ST 250	114,0	131,0	113,2	160	62	M 24x100	5,54
Nenndruck 400 bar / nominal pressure 400 bar									
400	3/8"	BS 38 ST 400	18,0	26,0	24,7	40	17	M 6x35	0,05
400	1/2"	BS 12 ST 400	24,0	31,8	29,7	45	14	M 8x30	0,09
400	3/4"	BS 34 ST 400	32,0	41,3	35,3	50	15	M 8x35	0,17
400	1"	BS 1 ST 400	38,0	47,6	43,8	65	16	M 10x40	0,27
400	1 1/4"	BS 114 ST 400	44,0	54,0	51,6	75	16	M 12x45	0,44
400	1 1/2"	BS 112 ST 400	51,0	63,5	60,0	85	19	M 14x55	0,65
400	2"	BS 2 ST 400	67,0	79,4	69,4	100	30	M 16x60	1,32
400	2 1/2"	BS 212 ST 400	80,0	94,2	83,4	120	45	M 20x70	2,13
400	3"	BS 3 ST 400	90,0	104,0	102,5	140	55	M 20x90	3,00
400	3 1/2"	BS 312 ST 400	102,0	119,0	102,5	140	54	M 20x90	3,90
400	4"	BS 4 ST 400	114,0	131,0	113,2	160	62	M 24x100	5,54

*1 oder vergleichbare Güte / or comparable material

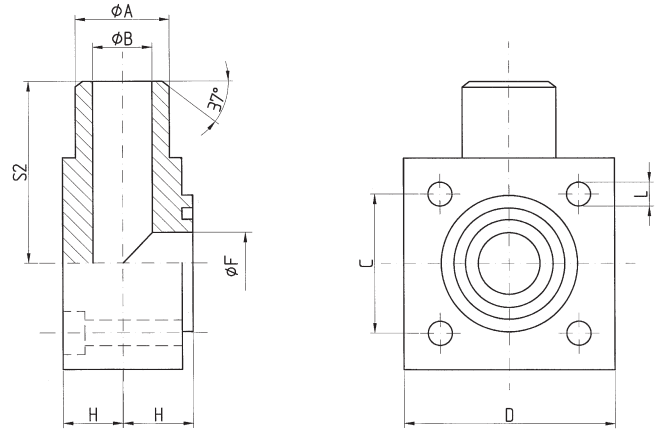

Bestellbezeichnung: ordering code:	S355J2^{*1}
• nur Flansch flange only	CET-.../90...
• incl. metrischem Schraubensatz und O-Ring including metric bolts and o-ring	CET-.../90...M

maximaler Betriebsdruck maximum recommended working pressure	S.A.E. Baugröße nominal flange size	Typ type	Abmessungen dimensions								Schrauben bolts	Gewicht weight
			A	B	C	D	F	H	L	S2		
kg/cm ²	inch										M	kg
Nenndruck 250 bar / nominal pressure 250 bar												
250	3/8"	CET 38 ST90 250	18	12,5	24,7	40	12,5	12	6,8	32	M 6x30	0,24
250	1/2"	CET 12 ST90 250	22	15,0	29,7	45	15,0	17	9,0	40	M 8x40	0,40
250	3/4"	CET 34 ST90 250	28	20,0	35,3	50	20,0	19	9,0	42	M 8x45	0,57
250	1"	CET 1 ST90 250	35	25,0	43,8	65	25,0	24	11,0	50	M 10x55	1,21
250	1 1/4"	CET 114 ST90 250	43	32,0	51,6	75	32,0	30	13,0	56	M 12x70	1,92
250	1 1/2"	CET 112 ST90 250	50	38,0	60,0	85	38,0	34	15,0	65	M 14x80	2,84
250	2"	CET 2 ST90 250	62	47,0	69,4	100	47,0	42	17,0	75	M 16x100	4,75
250	2 1/2"	CET 212 ST90 250	76	58,0	83,4	120	58,0	53	21,0	85	M 20x120	8,67
250	3"	CET 3 ST90 250	90	68,0	102,5	140	70,0	59	21,0	100	M 20x140	14,51
Nenndruck 400 bar / nominal pressure 400 bar												
400	3/8"	CET 38 ST90 400	18	11,0	24,7	40	12,5	12	6,8	32	M 6x30	0,24
400	1/2"	CET 12 ST90 400	22	14,0	29,7	45	15,0	17	9,0	40	M 8x40	0,40
400	3/4"	CET 34 ST90 400	28	18,0	35,3	50	20,0	19	9,0	42	M 8x45	0,59
400	1"	CET 1 ST90 400	35	22,0	43,8	65	25,0	24	11,0	50	M 10x55	1,25
400	1 1/4"	CET 114 ST90 400	44	29,0	51,6	75	32,0	30	13,0	56	M 12x70	2,00
400	1 1/2"	CET 112 ST90 400	51	35,0	60,0	85	38,0	34	15,0	65	M 14x80	2,86
400	2"	CET 2 ST90 400	61	43,0	69,4	100	47,0	42	17,0	75	M 16x100	4,83
400	2 1/2"	CET 212 ST90 400	80	53,0	83,4	120	58,0	53	21,0	85	M 20x120	8,58
400	3"	CET 3 ST90 400	90	58,0	102,5	140	58,0	59	21,0	100	M 20x140	14,51

*1 oder vergleichbare Güte / or comparable material

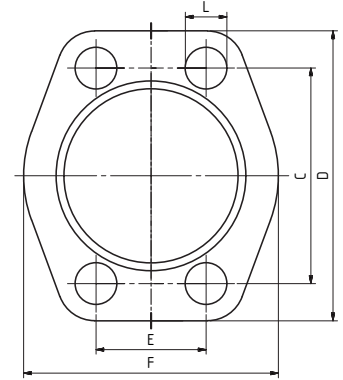
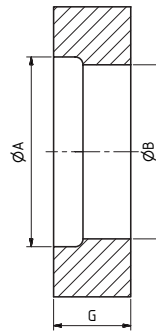

Bestellbezeichnung: ordering code:	S355J2^{*1}	1.4404^{*1}
• nur Vollflansch only flange	RRF-...	RRF-X-...

maximaler Betriebsdruck maximum recommended working pressure	S.A.E. Baugröße nominal flange size	Typ type	Abmessungen dimensions								Schrauben bolts		Gewicht weight	
			A	B	C	D	E	F	G	L	Einzel single	Kupplung coupling		
kg/cm ²	inch										metr.		kg	
Standarddruckreihe / Standard pressure														
350	1/2"	RRF-3001	30,5	26,5	38,1	54	17,5	46	20	9				
350	3/4"	RRF-3002	40,5	36,5	47,6	65	22,2	52,3	20	11				
350	1"	RRF-3003	44,5	39,5	52,4	70	26,2	58,7	20	11				
280	1 1/4"	RRF-3004	51,5	46,5	58,7	79,4	30,2	73,2	20	11				
280	1 1/2"	RRF-3005	61,5	56,5	69,9	94	35,7	82,6	25	13,5				
280	2"	RRF-3006	71,5	66,5	77,8	102,1 *2	42,9	96,8	30	13,5				
210	2 1/2"	RRF-3007	85,5	80,5	88,9	114,3	50,8	108,7	40	13,5				
210	3"	RRF-3008	103,5	97,5	106,4	135	61,9	131,1	50	17,5				
Hochdruckreihe / High pressure														
420	1/2"	RRF-6001	30,5	26,5	40,5	56	18,2	47,8	22	9				
420	3/4"	RRF-6002	40,5	36,5	50,8	71	23,8	60,5	23	11				
420	1"	RRF-6003	44,5	39,5	57,2	81	27,8	69,9	25	13,5				
420	1 1/4"	RRF-6004	51,5	46,5	66,7	95	31,8	77,7	30	15				
420	1 1/4"	RRF-6044	51,5	46,5	66,7	95	31,8	77,7	30	13,5				
420	1 1/2"	RRF-6005	61,5	56,5	79,4	112,8	36,5	95,3	33	17,5				
420	2"	RRF-6006	71,5	66,5	96,8	133	44,5	114,3	38	21				

*1 oder vergleichbare Güte / or comparable material
Oberfläche : CR-6 frei / surface CR-6 free

*2 Maß D bei 1.4404: 112,8 mm

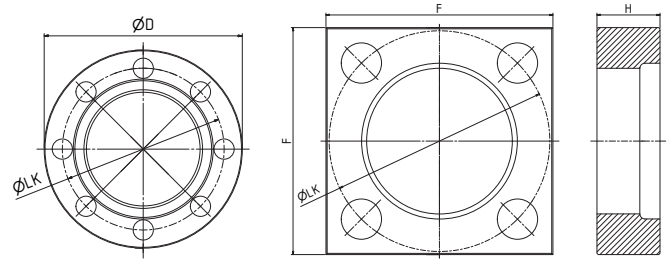

Bestellbezeichnung: ordering code:	S355J2^{*1}	1.4404^{*1}
• Vierkant-Halteringflansch retain ring flange	VKR-...	VKR-X-...

maximaler Betriebsdruck maximum recommended working pressure	Baugröße nominal flange size	Typ type	Abmessungen dimensions				Schrauben bolts	Gewicht weight
			LK	F	D	H		
kg/cm ²	inch					M	kg	
400	1 1/2"	VKR-38	85	90	–	35	4 x M16x60	1,2
400	2"	VKR-40	98	100	–	40	4 x M16x60	1,6
400	2 1/2"	VKR-50	118	120	–	40	4 x M20x70	2,7
400	3"	VKR-65	145	150	–	50	4 x M24x80	4,5
400	4"	VKR-80	175	180	–	50	4 x M30x100	7,6
350	5"	VKR-100	200	–	245	50	8 x M24x90	13,3
350	6"	VKR-125	245	–	300	70	8 x M30x120	21,8
350	8"	VKR-150	290	–	355	70	8 x M36x130	33,3

*1 oder vergleichbare Güte / or comparable material

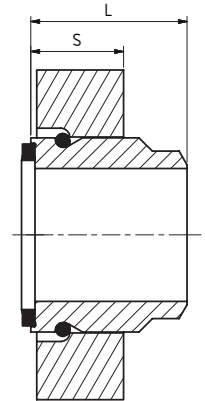
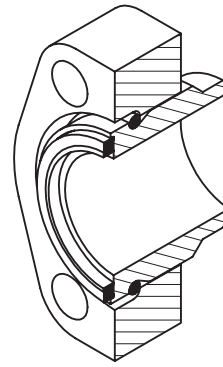

Bestellbezeichnung: ordering code:	S355J2^{*1}	1.4404^{*1}
• Vollflansch mit Bund, Haltering und Dichtung <i>flange clamp with weld neck, retaining ring and Bonded seal</i>	RRF-....	RRF-X-....
• Vollflansch mit Bund, Haltering, Dichtung + Schrauben <i>flange clamp with weld neck, retaining ring, Bonded seal + screws</i>	RRF-....M	RRF-X-....MX

S.A.E. Baugröße <i>nominal flange size</i>	Rohrmaß <i>pipe diameter</i>	Typ <i>type</i>					Gewicht <i>weight</i>
			L	S	Halteringbund	Halteringvollflansch	
<i>Inch</i>							<i>kg</i>
Standarddruckreihe / Standard pressure							
1/2"	12x1,5	RRF-301-12x1,5	45	23	RRF-001-12x1,5	RRF-3001	0,25
1/2"	16x2	RRF-301-16x2	40	23	RRF-001-16x2	RRF-3001	0,25
1/2"	18x2	RRF-301-18x2	40	23	RRF-001-18x2	RRF-3001	0,25
1/2"	20x2,5	RRF-301-20x2,5	40	23	RRF-001-20x2,5	RRF-3001	0,25
1/2"	21,3x2,1	RRF-301-21,3x2,1	40	23	RRF-001-21,3x2,1	RRF-3001	0,25
1/2"	21,3x2,8	RRF-301-21,3x2,8	40	23	RRF-001-21,3x2,8	RRF-3001	0,24
1/2"	21,3x3,7	RRF-301-21,3x3,7	40	23	RRF-001-21,3x3,7	RRF-3001	0,28
1/2"	21,3x4,8	RRF-301-21,3x4,8	40	23	RRF-001-21,3x4,8	RRF-3001	0,28
1/2"	21,3x7,5	RRF-301-21,3x7,5	40	23	RRF-001-21,3x7,5	RRF-3001	0,3
1/2"	25x2,5	RRF-301-25x2,5	45	23	RRF-001-25x2,5	RRF-3001	0,3
1/2"	26x6	RRF-301-26x6	40	23	RRF-001-26x6	RRF-3001	0,3
3/4"	20x2,5	RRF-302-20x2,5	40	23	RRF-002-20x2,5	RRF-3002	0,38
3/4"	25x3,0	RRF-302-25x3,0	40	23	RRF-002-25x3,0	RRF-3002	0,38
3/4"	26,7x2,1	RRF-302-26,7x2,1	40	23	RRF-002-26,7x2,1	RRF-3002	0,48
3/4"	26,7x2,9	RRF-302-26,7x2,9	40	23	RRF-002-26,7x2,9	RRF-3002	0,48
3/4"	26,7x3,9	RRF-302-26,7x3,9	40	23	RRF-002-26,7x3,9	RRF-3002	0,48
3/4"	26,7x5,6	RRF-302-26,7x5,6	40	23	RRF-002-26,7x5,6	RRF-3002	0,48
3/4"	26,7x7,82	RRF-302-26,7x7,82	40	23	RRF-002-26,7x7,82	RRF-3002	0,5
3/4"	30x3	RRF-302-30x3	40	23	RRF-002-30x3	RRF-3002	0,5
3/4"	30x4	RRF-302-30x4	40	23	RRF-002-30x4	RRF-3002	0,5
3/4"	30x6	RRF-302-30x6	40	23	RRF-002-30x6	RRF-3002	0,5
3/4"	36x8	RRF-302-36x8	45	23	RRF-002-36x8	RRF-3002	0,5
1"	25x3	RRF-303-25x3	40	22	RRF-003-25x3	RRF-3003	0,45
1"	30x4	RRF-303-30x4	40	22	RRF-003-30x4	RRF-3003	0,45
1"	33,4x2,8	RRF-303-33,4x2,8	40	22	RRF-003-33,4x2,8	RRF-3003	0,45
1"	33,4x3,4	RRF-303-33,4x3,4	40	22	RRF-003-33,4x3,4	RRF-3003	0,45
1"	33,4x4,6	RRF-303-33,4x4,6	40	22	RRF-003-33,4x4,6	RRF-3003	0,45
1"	33,4x6,4	RRF-303-33,4x6,4	50	22	RRF-003-33,4x6,4	RRF-3003	0,45
1"	33,4x9,1	RRF-303-33,4x9,1	50	22	RRF-003-33,4x9,1	RRF-3003	0,45
1"	38x4	RRF-303-38x4	40	22	RRF-003-38x4	RRF-3003	0,5

*1 oder vergleichbare Güte / or comparable material

S.A.E. Baugröße nominal flange size	Rohrmaß pipe diameter	Typ type	Standarddruckreihe / Standard pressure				Gewicht weight
			L	S	Halteringbund	Halteringvollflansch	
Inch						kg	
1"	38x5	RRF-303-38x5	40	22	RRF-003-38x5	RRF-3003	0,5
1"	38x7	RRF-303-38x7	40	22	RRF-003-38x7	RRF-3003	0,5
1"	39x7,5	RRF-303-39x7,5	50	22	RRF-003-39x7,5	RRF-3003	0,5
1 1/4"	30x4	RRF-304-30x4	40	23	RRF-004-30x4	RRF-3004	0,65
1 1/4"	38x5	RRF-304-38x5	40	23	RRF-004-38x5	RRF-3004	0,65
1 1/4"	42x4	RRF-304-42x4	40	23	RRF-004-42x4	RRF-3004	0,65
1 1/4"	42x6	RRF-304-42x6	40	23	RRF-004-42x6	RRF-3004	0,65
1 1/4"	42,2x2,8	RRF-304-42,2x2,8	40	23	RRF-004-42,2x2,8	RRF-3004	0,65
1 1/4"	42,2x3,6	RRF-304-42,2x3,6	40	23	RRF-004-42,2x3,6	RRF-3004	0,65
1 1/4"	42,2x4,9	RRF-304-42,2x4,9	40	23	RRF-004-42,2x4,9	RRF-3004	0,65
1 1/4"	42,2x6,4	RRF-304-42,2x6,4	50	23	RRF-004-42,2x6,4	RRF-3004	0,7
1 1/4"	42,2x9,7	RRF-304-42,2x9,7	50	23	RRF-004-42,2x9,7	RRF-3004	0,8
1 1/4"	46x7	RRF-304-46x7	50	23	RRF-004-46x7	RRF-3004	0,8
1 1/4"	46x8	RRF-304-46x8	55	23	RRF-004-46x8	RRF-3004	0,8
1 1/2"	38x5	RRF-305-38x5	45	28	RRF-005-38x5	RRF-3005	1,1
1 1/2"	48,3x2,8	RRF-305-48,3x2,8	45	28	RRF-005-48,3x2,8	RRF-3005	1,1
1 1/2"	48,3x3,7	RRF-305-48,3x3,7	45	28	RRF-005-48,3x3,7	RRF-3005	1,1
1 1/2"	48,3x5,1	RRF-305-48,3x5,1	45	28	RRF-005-48,3x5,1	RRF-3005	1,1
1 1/2"	48,3x7,1	RRF-305-48,3x7,1	60	28	RRF-005-48,3x7,1	RRF-3005	1,1
1 1/2"	48,3x10,2	RRF-305-48,3x10,2	60	28	RRF-005-48,3x10,2	RRF-3005	1,1
1 1/2"	50x5	RRF-305-50x5	45	28	RRF-005-50x5	RRF-3005	1,2
1 1/2"	50x6	RRF-305-50x6	45	28	RRF-005-50x6	RRF-3005	1,2
1 1/2"	50x9	RRF-305-50x9	45	28	RRF-005-50x9	RRF-3005	1,2
1 1/2"	56x8,5	RRF-305-56x8,5	60	28	RRF-005-56x8,5	RRF-3005	1,25
2"	48,3x5,1	RRF-306-48,3x5,1	50	33	RRF-006-48,3x5,1	RRF-3006	1,6
2"	50x9	RRF-306-50x9	50	33	RRF-006-50x9	RRF-3006	1,6
2"	60x5	RRF-306-60x5	50	33	RRF-006-60x5	RRF-3006	1,6
2"	60x6	RRF-306-60x6	50	33	RRF-006-60x6	RRF-3006	1,6
2"	60x8	RRF-306-60x8	50	33	RRF-006-60x8	RRF-3006	1,6
2"	60x10	RRF-306-60x10	50	33	RRF-006-60x10	RRF-3006	1,6
2"	60,3x2,8	RRF-306-60,3x2,8	50	33	RRF-006-60,3x2,8	RRF-3006	1,6
2"	60,3x3,9	RRF-306-60,3x3,9	50	33	RRF-006-60,3x3,9	RRF-3006	1,6
2"	60,3x5,6	RRF-306-60,3x5,6	50	33	RRF-006-60,3x5,6	RRF-3006	1,6
2"	60,3x8,8	RRF-306-60,3x8,8	75	33	RRF-006-60,3x8,8	RRF-3006	1,75
2"	60,3x11,1	RRF-306-60,3x11,1	75	33	RRF-006-60,3x11,1	RRF-3006	1,75
2"	66x8,5	RRF-306-66x8,5	75	33	RRF-006-66x8,5	RRF-3006	1,8
2 1/2"	65x8	RRF-307-65x8	50	43	RRF-007-65x8	RRF-3007	2,5
2 1/2"	73x7	RRF-307-73x7	50	43	RRF-007-73x7	RRF-3007	2,25
2 1/2"	75x5	RRF-307-75x5	50	43	RRF-007-75x5	RRF-3007	2,25
2 1/2"	76,1x6,3	RRF-307-76,1x6,3	50	43	RRF-007-76,1x6,3	RRF-3007	2,5
2 1/2"	76,1x12,5	RRF-307-76,1x12,5	50	43	RRF-007-76,1x12,5	RRF-3007	2,5
2 1/2"	80x10	RRF-307-80x10	90	43	RRF-007-80x10	RRF-3007	3
3"	76,1x12,5	RRF-308-76,1x12,5	60	56	RRF-008-76,1x12,5	RRF-3008	3,7
3"	80x10	RRF-308-80x10	60	56	RRF-008-80x10	RRF-3008	3,9
3"	88,9x3,2	RRF-308-88,9x3,2	60	56	RRF-008-88,9x3,2	RRF-3008	3,2
3"	88,9x5,5	RRF-308-88,9x5,5	60	56	RRF-008-88,9x5,5	RRF-3008	3,5
3"	88,9x7,6	RRF-308-88,9x7,6	110	56	RRF-008-88,9x7,6	RRF-3008	4,1
3"	88,9x8,8	RRF-308-88,9x8,8	60	56	RRF-008-88,9x8,8	RRF-3008	3,8
3"	88,9x11,1	RRF-308-88,9x11,1	110	56	RRF-008-88,9x11,1	RRF-3008	4,1
3"	88,9x12,5	RRF-308-88,9x12,5	60	56	RRF-008-88,9x12,5	RRF-3008	3,9
3"	88,9x15,3	RRF-308-88,9x15,3	110	56	RRF-008-88,9x15,3	RRF-3008	4,1
3"	90x5	RRF-308-90x5	60	56	RRF-008-90x5	RRF-3008	4,3
3"	97x12	RRF-308-97x12	110	56	RRF-008-97x12	RRF-3008	5

*1 oder vergleichbare Güte / or comparable material

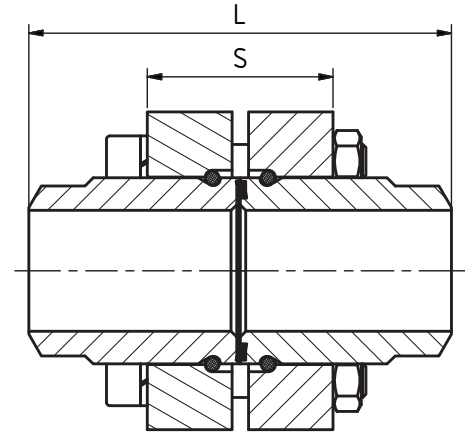

Bestellbezeichnung: ordering code:	S355J2^{*1}	1.4404^{*1}
• Vollflansch mit Bund, Haltering, Dichtung + Schrauben flange clamp with weld neck, retaining, Bonded seal + screws	RRK-...-...M	RRK-X-...-...MX

S.A.E. Baugröße nominal flange size	Rohrmaß pipe diameter	Typ type	Standarddruckreihe / Standard pressure					Gewicht weight
			L	S	Halteringbund	Halteringgegenbund	Halteringvollflansch	
1/2"	12x1,5	RRK-301-12x1,5M	90	46	RRF-001-12x1,5	GRRF-001-12x1,5	RRF-3001	0,5
1/2"	16x2	RRK-301-16x2M	80	46	RRF-001-16x2	GRRF-001-16x2	RRF-3001	0,5
1/2"	18x2	RRK-301-18x2M	80	46	RRF-001-18x2	GRRF-001-18x2	RRF-3001	0,5
1/2"	20x2,5	RRK-301-20x2,5M	80	46	RRF-001-20x2,5	GRRF-001-20x2,5	RRF-3001	0,5
1/2"	21,3x2,1	RRK-301-21,3x2,1M	80	46	RRF-001-21,3x2,1	GRRF-001-21,3x2,1	RRF-3001	0,5
1/2"	21,3x2,8	RRK-301-21,3x2,8M	80	46	RRF-001-21,3x2,8	GRRF-001-21,3x2,8	RRF-3001	0,48
1/2"	21,3x3,7	RRK-301-21,3x3,7M	80	46	RRF-001-21,3x3,7	GRRF-001-21,3x3,7	RRF-3001	0,56
1/2"	21,3x4,8	RRK-301-21,3x4,8M	80	46	RRF-001-21,3x4,8	GRRF-001-21,3x4,8	RRF-3001	0,56
1/2"	21,3x7,5	RRK-301-21,3x7,5M	80	46	RRF-001-21,3x7,5	GRRF-001-21,3x7,5	RRF-3001	0,6
1/2"	25x2,5	RRK-301-25x2,5M	90	46	RRF-001-25x2,5	GRRF-001-25x2,5	RRF-3001	0,6
1/2"	26x6	RRK-301-26x6M	80	46	RRF-001-26x6	GRRF-001-26x6	RRF-3001	0,6
3/4"	20x2,5	RRK-302-20x2,5M	80	46	RRF-002-20x2,5	GRRF-002-20x2,5	RRF-3002	0,76
3/4"	25x3,0	RRK-302-25x3,0M	80	46	RRF-002-25x3,0	GRRF-002-25x3,0	RRF-3002	0,76
3/4"	26,7x2,1	RRK-302-26,7x2,1M	80	46	RRF-002-26,7x2,1	GRRF-002-26,7x2,1	RRF-3002	0,96
3/4"	26,7x2,9	RRK-302-26,7x2,9M	80	46	RRF-002-26,7x2,9	GRRF-002-26,7x2,9	RRF-3002	0,96
3/4"	26,7x3,9	RRK-302-26,7x3,9M	80	46	RRF-002-26,7x3,9	GRRF-002-26,7x3,9	RRF-3002	0,96
3/4"	26,7x5,6	RRK-302-26,7x5,6M	80	46	RRF-002-26,7x5,6	GRRF-002-26,7x5,6	RRF-3002	0,96
3/4"	26,7x7,82	RRK-302-26,7x7,82M	80	46	RRF-002-26,7x7,82	GRRF-002-26,7x7,82	RRF-3002	1
3/4"	30x3	RRK-302-30x3M	80	46	RRF-002-30x3	GRRF-002-30x3	RRF-3002	1
3/4"	30x4	RRK-302-30x4M	80	46	RRF-002-30x4	GRRF-002-30x4	RRF-3002	1
3/4"	30x6	RRK-302-30x6M	80	46	RRF-002-30x6	GRRF-002-30x6	RRF-3002	1
3/4"	36x8	RRK-302-36x8M	90	46	RRF-002-36x8	GRRF-002-36x8	RRF-3002	1
1"	25x3	RRK-303-25x3M	80	44	RRF-003-25x3	GRRF-003-25x3	RRF-3003	0,9
1"	30x4	RRK-303-30x4M	80	44	RRF-003-30x4	GRRF-003-30x4	RRF-3003	0,9
1"	33,4x2,8	RRK-303-33,4x2,8M	80	44	RRF-003-33,4x2,8	GRRF-003-33,4x2,8	RRF-3003	0,9
1"	33,4x3,4	RRK-303-33,4x3,4M	80	44	RRF-003-33,4x3,4	GRRF-003-33,4x3,4	RRF-3003	0,9
1"	33,4x4,6	RRK-303-33,4x4,6M	80	44	RRF-003-33,4x4,6	GRRF-003-33,4x4,6	RRF-3003	0,9
1"	33,4x6,4	RRK-303-33,4x6,4M	100	44	RRF-003-33,4x6,4	GRRF-003-33,4x6,4	RRF-3003	0,9
1"	33,4x9,1	RRK-303-33,4x9,1M	100	44	RRF-003-33,4x9,1	GRRF-003-33,4x9,1	RRF-3003	0,9
1"	38x4	RRK-303-38x4M	80	44	RRF-003-38x4	GRRF-003-38x4	RRF-3003	1
1"	38x5	RRK-303-38x5M	80	44	RRF-003-38x5	GRRF-003-38x5	RRF-3003	1
1"	38x7	RRK-303-38x7M	80	44	RRF-003-38x7	GRRF-003-38x7	RRF-3003	1
1"	39x7,5	RRK-303-39x7,5M	100	44	RRF-003-39x7,5	GRRF-003-39x7,5	RRF-3003	1

*1 oder vergleichbare Güte / or comparable material

S.A.E. Baugröße nominal flange size	Rohrmaß pipe diameter	Typ type	Standarddruckreihe / Standard pressure					Gewicht weight
			L	S	Halteringbund	Halteringgegenbund	Halteringvollflansch	
Inch								kg
1 1/4"	30x4	RRK-304-30x4M	80	46	RRF-004-30x4	GRRF-004-30x4	RRF-3004	1,3
1 1/4"	38x5	RRK-304-38x5M	80	46	RRF-004-38x5	GRRF-004-38x5	RRF-3004	1,3
1 1/4"	42x4	RRK-304-42x4M	80	46	RRF-004-42x4	GRRF-004-42x4	RRF-3004	1,3
1 1/4"	42x6	RRK-304-42x6M	80	46	RRF-004-42x6	GRRF-004-42x6	RRF-3004	1,3
1 1/4"	42,2x2,8	RRK-304-42,2x2,8M	80	46	RRF-004-42,2x2,8	GRRF-004-42,2x2,8	RRF-3004	1,3
1 1/4"	42,2x3,6	RRK-304-42,2x3,6M	80	46	RRF-004-42,2x3,6	GRRF-004-42,2x3,6	RRF-3004	1,3
1 1/4"	42,2x4,9	RRK-304-42,2x4,9M	80	46	RRF-004-42,2x4,9	GRRF-004-42,2x4,9	RRF-3004	1,3
1 1/4"	42,2x6,4	RRK-304-42,2x6,4M	100	46	RRF-004-42,2x6,4	GRRF-004-42,2x6,4	RRF-3004	1,4
1 1/4"	42,2x9,7	RRK-304-42,2x9,7M	100	46	RRF-004-42,2x9,7	GRRF-004-42,2x9,7	RRF-3004	1,6
1 1/4"	46x7	RRK-304-46x7M	100	46	RRF-004-46x7	GRRF-004-46x7	RRF-3004	1,6
1 1/4"	46x8	RRK-304-46x8M	110	46	RRF-004-46x8	GRRF-004-46x8	RRF-3004	1,6
1 1/2"	38x5	RRK-305-38x5M	90	56	RRF-005-38x5	GRRF-005-38x5	RRF-3005	2,2
1 1/2"	48,3x2,8	RRK-305-48,3x2,8M	90	56	RRF-005-48,3x2,8	GRRF-005-48,3x2,8	RRF-3005	2,2
1 1/2"	48,3x3,7	RRK-305-48,3x3,7M	90	56	RRF-005-48,3x3,7	GRRF-005-48,3x3,7	RRF-3005	2,2
1 1/2"	48,3x5,1	RRK-305-48,3x5,1M	90	56	RRF-005-48,3x5,1	GRRF-005-48,3x5,1	RRF-3005	2,2
1 1/2"	48,3x7,1	RRK-305-48,3x7,1M	120	56	RRF-005-48,3x7,1	GRRF-005-48,3x7,1	RRF-3005	2,2
1 1/2"	48,3x10,2	RRK-305-48,3x10,2M	120	56	RRF-005-48,3x10,2	GRRF-005-48,3x10,2	RRF-3005	2,2
1 1/2"	50x5	RRK-305-50x5M	90	56	RRF-005-50x5	GRRF-005-50x5	RRF-3005	2,4
1 1/2"	50x6	RRK-305-50x6M	90	56	RRF-005-50x6	GRRF-005-50x6	RRF-3005	2,4
1 1/2"	50x9	RRK-305-50x9M	90	56	RRF-005-50x9	GRRF-005-50x9	RRF-3005	2,4
1 1/2"	56x8,5	RRK-305-56x8,5M	120	56	RRF-005-56x8,5	GRRF-005-56x8,5	RRF-3005	2,5
2"	48,3x5,1	RRK-306-48,3x5,1M	100	66	RRF-006-48,3x5,1	GRRF-006-48,3x5,1	RRF-3006	3,2
2"	50x9	RRK-306-50x9M	100	66	RRF-006-50x9	GRRF-006-50x9	RRF-3006	3,2
2"	60x5	RRK-306-60x5M	100	66	RRF-006-60x5	GRRF-006-60x5	RRF-3006	3,2
2"	60x6	RRK-306-60x6M	100	66	RRF-006-60x6	GRRF-006-60x6	RRF-3006	3,2
2"	60x8	RRK-306-60x8M	100	66	RRF-006-60x8	GRRF-006-60x8	RRF-3006	3,2
2"	60x10	RRK-306-60x10M	100	66	RRF-006-60x10	GRRF-006-60x10	RRF-3006	3,2
2"	60,3x2,8	RRK-306-60,3x2,8M	100	66	RRF-006-60,3x2,8	GRRF-006-60,3x2,8	RRF-3006	3,2
2"	60,3x3,9	RRK-306-60,3x3,9M	100	66	RRF-006-60,3x3,9	GRRF-006-60,3x3,9	RRF-3006	3,2
2"	60,3x5,6	RRK-306-60,3x5,6M	100	66	RRF-006-60,3x5,6	GRRF-006-60,3x5,6	RRF-3006	3,2
2"	60,3x8,8	RRK-306-60,3x8,8M	150	66	RRF-006-60,3x8,8	GRRF-006-60,3x8,8	RRF-3006	3,5
2"	60,3x11,1	RRK-306-60,3x11,1M	150	66	RRF-006-60,3x11,1	GRRF-006-60,3x11,1	RRF-3006	3,5
2"	66x8,5	RRK-306-66x8,5M	150	66	RRF-006-66x8,5	GRRF-006-66x8,5	RRF-3006	3,6
2 1/2"	65x8	RRK-307-65x8M	100	86	RRF-007-65x8	GRRF-007-65x8	RRF-3007	5
2 1/2"	73x7	RRK-307-73x7M	100	86	RRF-007-73x7	GRRF-007-73x7	RRF-3007	4,5
2 1/2"	75x5	RRK-307-75x5M	100	86	RRF-007-75x5	GRRF-007-75x5	RRF-3007	4,5
2 1/2"	76,1x6,3	RRK-307-76,1x6,3M	100	86	RRF-007-76,1x6,3	GRRF-007-76,1x6,3	RRF-3007	5
2 1/2"	76,1x12,5	RRK-307-76,1x12,5M	100	86	RRF-007-76,1x12,5	GRRF-007-76,1x12,5	RRF-3007	5
2 1/2"	80x10	RRK-307-80x10M	180	86	RRF-007-80x10	GRRF-007-80x10	RRF-3007	6
3"	76,1x12,5	RRK-308-76,1x12,5M	120	112	RRF-008-76,1x12,5	GRRF-008-76,1x12,5	RRF-3008	7,4
3"	80x10	RRK-308-80x10M	120	112	RRF-008-80x10	GRRF-008-80x10	RRF-3008	7,8
3"	88,9x3,2	RRK-308-88,9x3,2M	120	112	RRF-008-88,9x3,2	GRRF-008-88,9x3,2	RRF-3008	6,4
3"	88,9x5,5	RRK-308-88,9x5,5M	120	112	RRF-008-88,9x5,5	GRRF-008-88,9x5,5	RRF-3008	7
3"	88,9x7,6	RRK-308-88,9x7,6M	220	112	RRF-008-88,9x7,6	GRRF-008-88,9x7,6	RRF-3008	8,2
3"	88,9x8,8	RRK-308-88,9x8,8M	120	112	RRF-008-88,9x8,8	GRRF-008-88,9x8,8	RRF-3008	7,6
3"	88,9x11,1	RRK-308-88,9x11,1M	220	112	RRF-008-88,9x11,1	GRRF-008-88,9x11,1	RRF-3008	8,2
3"	88,9x12,5	RRK-308-88,9x12,5M	120	112	RRF-008-88,9x12,5	GRRF-008-88,9x12,5	RRF-3008	7,8
3"	88,9x15,3	RRK-308-88,9x15,3M	220	112	RRF-008-88,9x15,3	GRRF-008-88,9x15,3	RRF-3008	8,2
3"	90x5	RRK-308-90x5M	120	112	RRF-008-90x5	GRRF-008-90x5	RRF-3008	8,6
3"	97x12	RRK-308-97x12M	220	112	RRF-008-97x12	GRRF-008-97x12	RRF-3008	10

*1 oder vergleichbare Güte / or comparable material

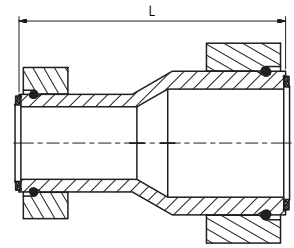
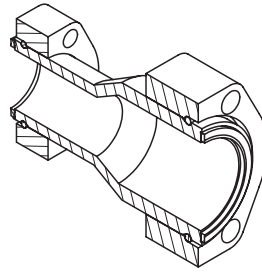

Bestellbezeichnung: ordering code:	S355J2^{*1}	1.4404^{*1}
• Reduzierbund, 2x Vollflansch, Haltering und Dichtung <i>reduction, 2x flange clamp, retaining and Bonded seal</i>	RRF-RED-...-...	RRF-RED-X-...-...
• Reduzierbund, 2x Vollflansch, Haltering, Dichtung + Schrauben <i>reduction, 2x flange clamp, retaining, Bonded seal + screws</i>	RRF-RED-...-...M	RRF-RED-X-...-...MX

S.A.E. Baugröße nominal flange size	Typ type					Gewicht weight
		L	Halteringflansch 1	Halteringflansch 2	Reduzierbund	
Inch						kg
Standarddruckreihe / Standard pressure						
3/4" - 1/2"	RRF-RED-302-301	65	RRF-3002	RRF-3001	RRF-RED-002-001	0,75
1" - 3/4"	RRF-RED-303-302	110	RRF-3003	RRF-3002	RRF-RED-003-002	1,1
1" - 1/2"	RRF-RED-303-301	80	RRF-3003	RRF-3001	RRF-RED-003-001	1,1
1 1/4" - 1"	RRF-RED-304-303	110	RRF-3004	RRF-3003	RRF-RED-004-003	1,4
1 1/4" - 3/4"	RRF-RED-304-302	110	RRF-3004	RRF-3002	RRF-RED-004-002	1,3
1 1/2" - 1 1/4"	RRF-RED-305-304	130	RRF-3005	RRF-3004	RRF-RED-005-004	2,1
1 1/2" - 1"	RRF-RED-305-303	110	RRF-3005	RRF-3003	RRF-RED-005-003	1,8
2" - 1 1/2"	RRF-RED-306-305	130	RRF-3006	RRF-3005	RRF-RED-006-005	3
2" - 1 1/4"	RRF-RED-306-304	130	RRF-3006	RRF-3004	RRF-RED-006-004	2,5
2 1/2" - 2"	RRF-RED-307-306	150	RRF-3007	RRF-3006	RRF-RED-007-006	4,6
2 1/2" - 1 1/2"	RRF-RED-307-305	150	RRF-3007	RRF-3005	RRF-RED-007-005	4
3" - 2 1/2"	RRF-RED-308-307	180	RRF-3008	RRF-3007	RRF-RED-008-007	7,7
3" - 2"	RRF-RED-308-306	180	RRF-3008	RRF-3006	RRF-RED-008-006	6,6

*1 oder vergleichbare Güte / or comparable material

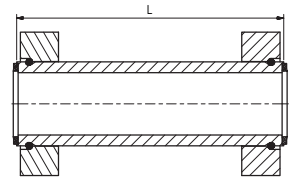
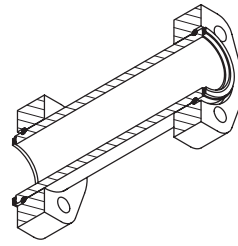

Bestellbezeichnung: ordering code:	S355J2^{*1}	1.4404^{*1}
• Vollflansch mit Bund, Haltering und Dichtung <i>flange clamp with weld neck, retaining and Bonded seal</i>	RRF-....	RRF-X-....
• Vollflansch mit Bund, Haltering, Dichtung + Schrauben <i>flange clamp with weld neck, retaining, Bonded seal + screws</i>	RRF-....M	RRF-X-....MX

S.A.E. Baugröße <i>nominal flange size</i>	Typ <i>type</i>					Gewicht <i>weight</i>
		L	Benötigte Schottöffnung	Halteringflansche	Schottbund	
Inch						kg
Standarddruckreihe / Standard pressure						
1/2"	RRF-B-301	170	27	RRF-3001	RRF-B-001	1,2
3/4"	RRF-B-302	170	37	RRF-3002	RRF-B-002	1,4
1"	RRF-B-303	170	40	RRF-3003	RRF-B-003	1,6
1 1/4"	RRF-B-304	180	47	RRF-3004	RRF-B-004	2,2
1 1/2"	RRF-B-305	180	57	RRF-3005	RRF-B-005	3,1
2"	RRF-B-306	210	68	RRF-3006	RRF-B-006	4,5
2 1/2"	RRF-B-307	220	82	RRF-3007	RRF-B-007	6,8
3"	RRF-B-308	240	99	RRF-3008	RRF-B-008	10,9

*1 oder vergleichbare Güte / or comparable material

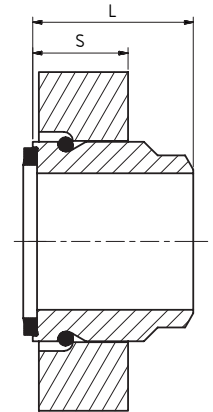
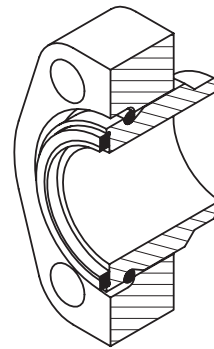

Bestellbezeichnung: ordering code:	S355J2^{*1}	1.4404^{*1}
• Vollflansch mit Bund, Haltering und Dichtung <i>flange clamp with weld neck, retaining and Bonded seal</i>	RRF-....	RRF-X-....
• Vollflansch mit Bund, Haltering, Dichtung + Schrauben <i>flange clamp with weld neck, retaining, Bonded seal + screws</i>	RRF-....M	RRF-X-....MX

S.A.E. Baugröße <i>nominal flange size</i>	Rohrmaß <i>pipe diameter</i>	Typ <i>type</i>					Gewicht <i>weight</i>
			L	S	Halteringbund	Bördelvollflansch	
Hochdruckreihe / High pressure							
1/2"	12x1,5	RRF-601-12x1,5	45	23	RRF-001-12x1,5	RRF-6001	0,3
1/2"	16x2	RRF-601-16x2	40	23	RRF-001-16x2	RRF-6001	0,3
1/2"	18x2	RRF-601-18x2	40	23	RRF-001-18x2	RRF-6001	0,3
1/2"	20x2,5	RRF-601-20x2,5	40	23	RRF-001-20x2,5	RRF-6001	0,3
1/2"	21,3x2,1	RRF-601-21,3x2,1	40	23	RRF-001-21,3x2,1	RRF-6001	0,3
1/2"	21,3x2,8	RRF-601-21,3x2,8	40	23	RRF-001-21,3x2,8	RRF-6001	0,3
1/2"	21,3x3,7	RRF-601-21,3x3,7	40	23	RRF-001-21,3x3,7	RRF-6001	0,3
1/2"	21,3x4,8	RRF-601-21,3x4,8	40	23	RRF-001-21,3x4,8	RRF-6001	0,3
1/2"	21,3x7,5	RRF-601-21,3x7,5	40	23	RRF-001-21,3x7,5	RRF-6001	0,3
1/2"	25x2,5	RRF-601-25x2,5	45	23	RRF-001-25x2,5	RRF-6001	0,3
1/2"	26x6	RRF-601-26x6	40	23	RRF-001-26x6	RRF-6001	0,3
3/4"	20x2,5	RRF-602-20x2,5	40	23	RRF-002-20x2,5	RRF-6002	0,5
3/4"	25x3,0	RRF-602-25x3,0	40	23	RRF-002-25x3,0	RRF-6002	0,55
3/4"	26,7x2,1	RRF-602-26,7x2,1	40	23	RRF-002-26,7x2,1	RRF-6002	0,55
3/4"	26,7x2,9	RRF-602-26,7x2,9	40	23	RRF-002-26,7x2,9	RRF-6002	0,55
3/4"	26,7x3,9	RRF-602-26,7x3,9	40	23	RRF-002-26,7x3,9	RRF-6002	0,55
3/4"	26,7x5,6	RRF-602-26,7x5,6	40	23	RRF-002-26,7x5,6	RRF-6002	0,55
3/4"	26,7x7,82	RRF-602-26,7x7,82	40	23	RRF-002-26,7x7,82	RRF-6002	0,55
3/4"	30x3	RRF-602-30x3	40	23	RRF-002-30x3	RRF-6002	0,55
3/4"	30x4	RRF-602-30x4	40	23	RRF-002-30x4	RRF-6002	0,55
3/4"	30x6	RRF-602-30x6	40	23	RRF-002-30x6	RRF-6002	0,55
3/4"	36x8	RRF-602-36x8	45	23	RRF-002-36x8	RRF-6002	0,6
1"	25x3	RRF-603-25x3	40	22	RRF-003-25x3	RRF-6003	0,75
1"	30x4	RRF-603-30x4	40	22	RRF-003-30x4	RRF-6003	0,75
1"	33,4x2,8	RRF-603-33,4x2,8	40	22	RRF-003-33,4x2,8	RRF-6003	0,75
1"	33,4x3,4	RRF-603-33,4x3,4	40	22	RRF-003-33,4x3,4	RRF-6003	0,75

*1 oder vergleichbare Güte / or comparable material

S.A.E. Baugröße nominal flange size	Rohrmaß pipe diameter	Typ type					Gewicht weight
			L	S	Halteringbund	Bördelvollflansch	
Inch							
Hochdruckreihe / High pressure							
1"	33,4x4,6	RRF-603-33,4x4,6	40	22	RRF-003-33,4x4,6	RRF-6003	0,75
1"	33,4x6,4	RRF-603-33,4x6,4	50	22	RRF-003-33,4x6,4	RRF-6003	0,75
1"	33,4x9,1	RRF-603-33,4x9,1	50	22	RRF-003-33,4x9,1	RRF-6003	0,75
1"	38x4	RRF-603-38x4	40	22	RRF-003-38x4	RRF-6003	0,75
1"	38x5	RRF-603-38x5	40	22	RRF-003-38x5	RRF-6003	0,8
1"	38x7	RRF-603-38x7	40	22	RRF-003-38x7	RRF-6003	0,8
1"	39x7,5	RRF-603-39x7,5	50	22	RRF-003-39x7,5	RRF-6003	0,9
1 1/4"	30x4	RRF-604-30x4	40	23	RRF-004-30x4	RRF-6004	1,1
1 1/4"	38x5	RRF-604-38x5	40	23	RRF-004-38x5	RRF-6004	1,1
1 1/4"	42x4	RRF-604-42x4	40	23	RRF-004-42x4	RRF-6004	1
1 1/4"	42x6	RRF-604-42x6	40	23	RRF-004-42x6	RRF-6004	1,1
1 1/4"	42,2x2,8	RRF-604-42,2x2,8	40	23	RRF-004-42,2x2,8	RRF-6004	1,1
1 1/4"	42,2x3,6	RRF-604-42,2x3,6	40	23	RRF-004-42,2x3,6	RRF-6004	1,1
1 1/4"	42,2x4,9	RRF-604-42,2x4,9	40	23	RRF-004-42,2x4,9	RRF-6004	1,2
1 1/4"	42,2x6,4	RRF-604-42,2x6,4	50	23	RRF-004-42,2x6,4	RRF-6004	1,2
1 1/4"	42,2x9,7	RRF-604-42,2x9,7	50	23	RRF-004-42,2x9,7	RRF-6004	1,3
1 1/4"	46x7	RRF-604-46x7	50	23	RRF-004-46x7	RRF-6004	1,3
1 1/4"	46x8	RRF-604-46x8	55	23	RRF-004-46x8	RRF-6004	1,3
1 1/2"	38x5	RRF-605-38x5	45	28	RRF-005-38x5	RRF-6005	1,8
1 1/2"	48,3x2,8	RRF-605-48,3x2,8	45	28	RRF-005-48,3x2,8	RRF-6005	1,8
1 1/2"	48,3x3,7	RRF-605-48,3x3,7	45	28	RRF-005-48,3x3,7	RRF-6005	1,8
1 1/2"	48,3x5,1	RRF-605-48,3x5,1	45	28	RRF-005-48,3x5,1	RRF-6005	1,8
1 1/2"	48,3x7,1	RRF-605-48,3x7,1	60	28	RRF-005-48,3x7,1	RRF-6005	2
1 1/2"	48,3x10,2	RRF-605-48,3x10,2	60	28	RRF-005-48,3x10,2	RRF-6005	2
1 1/2"	50x5	RRF-605-50x5	45	28	RRF-005-50x5	RRF-6005	1,8
1 1/2"	50x6	RRF-605-50x6	45	28	RRF-005-50x6	RRF-6005	1,8
1 1/2"	50x9	RRF-605-50x9	45	28	RRF-005-50x9	RRF-6005	2
1 1/2"	56x8,5	RRF-605-56x8,5	60	28	RRF-005-56x8,5	RRF-6005	2,1
2"	48,3x5,1	RRF-606-48,3x5,1	50	33	RRF-006-48,3x5,1	RRF-6006	2,8
2"	50x9	RRF-606-50x9	50	33	RRF-006-50x9	RRF-6006	2,8
2"	60x5	RRF-606-60x5	50	33	RRF-006-60x5	RRF-6006	2,9
2"	60x6	RRF-606-60x6	50	33	RRF-006-60x6	RRF-6006	2,9
2"	60x8	RRF-606-60x8	50	33	RRF-006-60x8	RRF-6006	2,9
2"	60x10	RRF-606-60x10	50	33	RRF-006-60x10	RRF-6006	2,9
2"	60,3x2,8	RRF-606-60,3x2,8	50	33	RRF-006-60,3x2,8	RRF-6006	2,9
2"	60,3x3,9	RRF-606-60,3x3,9	50	33	RRF-006-60,3x3,9	RRF-6006	2,9
2"	60,3x5,6	RRF-606-60,3x5,6	50	33	RRF-006-60,3x5,6	RRF-6006	2,9
2"	60,3x8,8	RRF-606-60,3x8,8	75	33	RRF-006-60,3x8,8	RRF-6006	3
2"	60,3x11,1	RRF-606-60,3x11,1	75	33	RRF-006-60,3x11,1	RRF-6006	3,1

*1 oder vergleichbare Güte / or comparable material

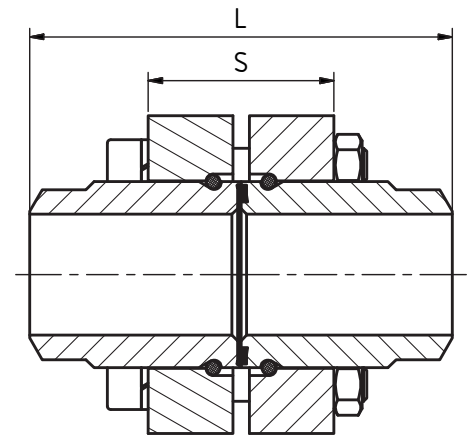

Bestellbezeichnung: ordering code:	S355J2^{*1}	1.4404^{*1}
• Vollflansch mit Bund, Haltering, Dichtung + Schrauben flange clamp with weld neck, retaining, Bonded seal + screws	RRK-...-...M	RRK-X-...-...MX

S.A.E. Baugröße nominal flange size	Rohrmaß pipe diameter	Typ type						Gewicht weight
			L	S	Halteringbund	Halteringgegenbund	Halteringvollflansch	
Standarddruckreihe / Standard pressure								
1/2"	12x1,5	RRK-601-12x1,5M	180	92	RRF-001-12x1,5	GRRF-001-12x1,5	RRF-6001	0,6
1/2"	16x2	RRK-601-16x2M	160	92	RRF-001-16x2	GRRF-001-16x2	RRF-6001	0,6
1/2"	18x2	RRK-601-18x2M	160	92	RRF-001-18x2	GRRF-001-18x2	RRF-6001	0,6
1/2"	20x2,5	RRK-601-20x2,5M	160	92	RRF-001-20x2,5	GRRF-001-20x2,5	RRF-6001	0,6
1/2"	21,3x2,1	RRK-601-21,3x2,1M	160	92	RRF-001-21,3x2,1	GRRF-001-21,3x2,1	RRF-6001	0,6
1/2"	21,3x2,8	RRK-601-21,3x2,8M	160	92	RRF-001-21,3x2,8	GRRF-001-21,3x2,8	RRF-6001	0,6
1/2"	21,3x3,7	RRK-601-21,3x3,7M	160	92	RRF-001-21,3x3,7	GRRF-001-21,3x3,7	RRF-6001	0,6
1/2"	21,3x4,8	RRK-601-21,3x4,8M	160	92	RRF-001-21,3x4,8	GRRF-001-21,3x4,8	RRF-6001	0,6
1/2"	21,3x7,5	RRK-601-21,3x7,5M	160	92	RRF-001-21,3x7,5	GRRF-001-21,3x7,5	RRF-6001	0,6
1/2"	25x2,5	RRK-601-25x2,5M	180	92	RRF-001-25x2,5	GRRF-001-25x2,5	RRF-6001	0,6
1/2"	26x6	RRK-601-26x6M	160	92	RRF-001-26x6	GRRF-001-26x6	RRF-6001	0,6
3/4"	20x2,5	RRK-602-20x2,5M	160	92	RRF-002-20x2,5	GRRF-002-20x2,5	RRF-6002	1
3/4"	25x3,0	RRK-602-25x3,0M	160	92	RRF-002-25x3,0	GRRF-002-25x3,0	RRF-6002	1,1
3/4"	26,7x2,1	RRK-602-26,7x2,1M	160	92	RRF-002-26,7x2,1	GRRF-002-26,7x2,1	RRF-6002	1,1
3/4"	26,7x2,9	RRK-602-26,7x2,9M	160	92	RRF-002-26,7x2,9	GRRF-002-26,7x2,9	RRF-6002	1,1
3/4"	26,7x3,9	RRK-602-26,7x3,9M	160	92	RRF-002-26,7x3,9	GRRF-002-26,7x3,9	RRF-6002	1,1
3/4"	26,7x5,6	RRK-602-26,7x5,6M	160	92	RRF-002-26,7x5,6	GRRF-002-26,7x5,6	RRF-6002	1,1
3/4"	26,7x7,82	RRK-602-26,7x7,82M	160	92	RRF-002-26,7x7,82	GRRF-002-26,7x7,82	RRF-6002	1,1
3/4"	30x3	RRK-602-30x3M	160	92	RRF-002-30x3	GRRF-002-30x3	RRF-6002	1,1
3/4"	30x4	RRK-602-30x4M	160	92	RRF-002-30x4	GRRF-002-30x4	RRF-6002	1,1
3/4"	30x6	RRK-602-30x6M	160	92	RRF-002-30x6	GRRF-002-30x6	RRF-6002	1,1
3/4"	36x8	RRK-602-36x8M	180	92	RRF-002-36x8	GRRF-002-36x8	RRF-6002	1,2
1"	25x3	RRK-603-25x3M	160	88	RRF-003-25x3	GRRF-003-25x3	RRF-6003	1,5
1"	30x4	RRK-603-30x4M	160	88	RRF-003-30x4	GRRF-003-30x4	RRF-6003	1,5
1"	33,4x2,8	RRK-603-33,4x2,8M	160	88	RRF-003-33,4x2,8	GRRF-003-33,4x2,8	RRF-6003	1,5
1"	33,4x3,4	RRK-603-33,4x3,4M	160	88	RRF-003-33,4x3,4	GRRF-003-33,4x3,4	RRF-6003	1,5

*1 oder vergleichbare Güte / or comparable material

S.A.E. Baugröße <i>nominal flange size</i>	Rohrmaß <i>pipe diameter</i>	Typ <i>type</i>						Gewicht <i>weight</i>
			L	S	Halteringbund	Halteringgegenbund	Halteringvollflansch	
Standarddruckreihe / Standard pressure								
1"	33,4x4,6	RRK-603-33,4x4,6M	160	88	RRF-003-33,4x4,6	GRRF-003-33,4x4,6	RRF-6003	1,5
1"	33,4x6,4	RRK-603-33,4x6,4M	200	88	RRF-003-33,4x6,4	GRRF-003-33,4x6,4	RRF-6003	1,5
1"	33,4x9,1	RRK-603-33,4x9,1M	200	88	RRF-003-33,4x9,1	GRRF-003-33,4x9,1	RRF-6003	1,5
1"	38x4	RRK-603-38x4M	160	88	RRF-003-38x4	GRRF-003-38x4	RRF-6003	1,5
1"	38x5	RRK-603-38x5M	160	88	RRF-003-38x5	GRRF-003-38x5	RRF-6003	1,6
1"	38x7	RRK-603-38x7M	160	88	RRF-003-38x7	GRRF-003-38x7	RRF-6003	1,6
1"	39x7,5	RRK-603-39x7,5M	200	88	RRF-003-39x7,5	GRRF-003-39x7,5	RRF-6003	1,8
1/4"	30x4	RRK-604-30x4M	160	92	RRF-004-30x4	GRRF-004-30x4	RRF-6004	2,2
1/4"	38x5	RRK-604-38x5M	160	92	RRF-004-38x5	GRRF-004-38x5	RRF-6004	2,2
1/4"	42x4	RRK-604-42x4M	160	92	RRF-004-42x4	GRRF-004-42x4	RRF-6004	2
1/4"	42x6	RRK-604-42x6M	160	92	RRF-004-42x6	GRRF-004-42x6	RRF-6004	2,2
1/4"	42,2x2,8	RRK-604-42,2x2,8M	160	92	RRF-004-42,2x2,8	GRRF-004-42,2x2,8	RRF-6004	2,2
1/4"	42,2x3,6	RRK-604-42,2x3,6M	160	92	RRF-004-42,2x3,6	GRRF-004-42,2x3,6	RRF-6004	2,2
1/4"	42,2x4,9	RRK-604-42,2x4,9M	160	92	RRF-004-42,2x4,9	GRRF-004-42,2x4,9	RRF-6004	2,4
1/4"	42,2x6,4	RRK-604-42,2x6,4M	200	92	RRF-004-42,2x6,4	GRRF-004-42,2x6,4	RRF-6004	2,4
1/4"	42,2x9,7	RRK-604-42,2x9,7M	200	92	RRF-004-42,2x9,7	GRRF-004-42,2x9,7	RRF-6004	2,6
1/4"	46x7	RRK-604-46x7M	200	92	RRF-004-46x7	GRRF-004-46x7	RRF-6004	2,6
1/4"	46x8	RRK-604-46x8M	200	92	RRF-004-46x8	GRRF-004-46x8	RRF-6004	2,6
1/2"	38x5	RRK-605-38x5M	180	112	RRF-005-38x5	GRRF-005-38x5	RRF-6005	3,6
1/2"	48,3x2,8	RRK-605-48,3x2,8M	180	112	RRF-005-48,3x2,8	GRRF-005-48,3x2,8	RRF-6005	3,6
1/2"	48,3x3,7	RRK-605-48,3x3,7M	180	112	RRF-005-48,3x3,7	GRRF-005-48,3x3,7	RRF-6005	3,6
1/2"	48,3x5,1	RRK-605-48,3x5,1M	180	112	RRF-005-48,3x5,1	GRRF-005-48,3x5,1	RRF-6005	3,6
1/2"	48,3x7,1	RRK-605-48,3x7,1M	240	112	RRF-005-48,3x7,1	GRRF-005-48,3x7,1	RRF-6005	4
1/2"	48,3x10,2	RRK-605-48,3x10,2M	240	112	RRF-005-48,3x10,2	GRRF-005-48,3x10,2	RRF-6005	4
1/2"	50x5	RRK-605-50x5M	180	112	RRF-005-50x5	GRRF-005-50x5	RRF-6005	3,6
1/2"	50x6	RRK-605-50x6M	180	112	RRF-005-50x6	GRRF-005-50x6	RRF-6005	3,6
1/2"	50x9	RRK-605-50x9M	180	112	RRF-005-50x9	GRRF-005-50x9	RRF-6005	4
1/2"	56x8,5	RRK-605-56x8,5M	240	112	RRF-005-56x8,5	GRRF-005-56x8,5	RRF-6005	4,2
2"	48,3x5,1	RRK-606-48,3x5,1M	200	132	RRF-006-48,3x5,1	GRRF-006-48,3x5,1	RRF-6006	5,6
2"	50x9	RRK-606-50x9M	200	132	RRF-006-50x9	GRRF-006-50x9	RRF-6006	5,6
2"	60x5	RRK-606-60x5M	200	132	RRF-006-60x5	GRRF-006-60x5	RRF-6006	5,8
2"	60x6	RRK-606-60x6M	200	132	RRF-006-60x6	GRRF-006-60x6	RRF-6006	5,8
2"	60x8	RRK-606-60x8M	200	132	RRF-006-60x8	GRRF-006-60x8	RRF-6006	5,8
2"	60x10	RRK-606-60x10M	200	132	RRF-006-60x10	GRRF-006-60x10	RRF-6006	5,8
2"	60,3x2,8	RRK-606-60,3x2,8M	200	132	RRF-006-60,3x2,8	GRRF-006-60,3x2,8	RRF-6006	5,8
2"	60,3x3,9	RRK-606-60,3x3,9M	200	132	RRF-006-60,3x3,9	GRRF-006-60,3x3,9	RRF-6006	5,8
2"	60,3x5,6	RRK-606-60,3x5,6M	200	132	RRF-006-60,3x5,6	GRRF-006-60,3x5,6	RRF-6006	5,8
2"	60,3x8,8	RRK-606-60,3x8,8M	300	132	RRF-006-60,3x8,8	GRRF-006-60,3x8,8	RRF-6006	6
2"	60,3x11,1	RRK-606-60,3x11,1M	300	132	RRF-006-60,3x11,1	GRRF-006-60,3x11,1	RRF-6006	6,2
2"	66x8,5	RRK-606-66x8,5M	300	132	RRF-006-66x8,5	GRRF-006-66x8,5	RRF-6006	6,4

*1 oder vergleichbare Güte / or comparable material

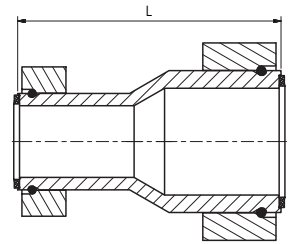
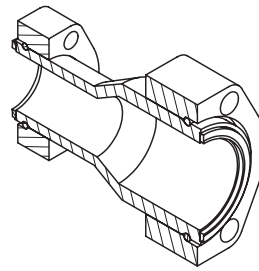
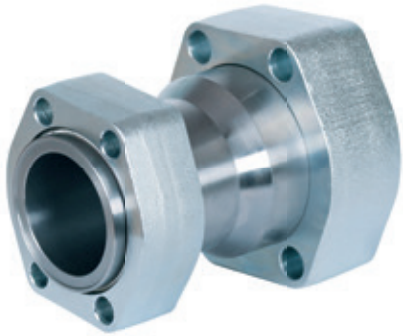

Bestellbezeichnung: ordering code:	S355J2^{*1}	1.4404^{*1}
<ul style="list-style-type: none"> • Reduzierbund, 2x Vollflansch, Haltering und Dichtung <i>reduction, 2x flange clamp, retaining and Bonded seal</i> • Reduzierbund, 2x Vollflansch, Haltering, Dichtung + Schrauben <i>reduction, 2x flange clamp, retaining, Bonded seal + screws</i> 	RRF-RED-...-... RRF-RED-...-...M	RRF-RED-X-...-... MX

S.A.E. Baugröße nominal flange size	Typ type	L	Halteringflansch 1	Halteringflansch 2	Reduzierbund	Gewicht weight
Inch						kg
Hochdruckreihe / High pressure						
3/4" - 1/2"	RRF-RED-602-601	65	RRF-6002	RRF-6001	RRF-RED-002-001	0,9
1" - 3/4"	RRF-RED-603-602	110	RRF-6003	RRF-6002	RRF-RED-003-002	1,6
1" - 1/2"	RRF-RED-603-601	80	RRF-6003	RRF-6001	RRF-RED-003-001	1,2
1 1/4" - 1"	RRF-RED-604-603	110	RRF-6004	RRF-6003	RRF-RED-004-003	2,1
1 1/4" - 3/4"	RRF-RED-604-602	110	RRF-6004	RRF-6002	RRF-RED-004-002	1,9
1 1/2" - 1 1/4"	RRF-RED-605-604	130	RRF-6005	RRF-6004	RRF-RED-005-004	3,3
1 1/2" - 1"	RRF-RED-605-603	110	RRF-6005	RRF-6003	RRF-RED-005-003	2,8
2" - 1 1/2"	RRF-RED-606-605	130	RRF-6006	RRF-6005	RRF-RED-006-005	5
2" - 1 1/4"	RRF-RED-606-604	130	RRF-6006	RRF-6004	RRF-RED-006-004	4,2

*1 oder vergleichbare Güte / or comparable material

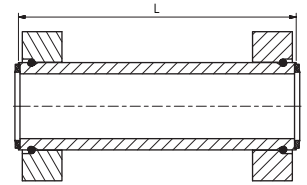
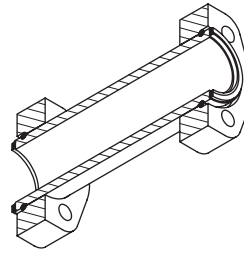

Bestellbezeichnung: ordering code:	S355J2^{*1}	1.4404^{*1}
• Schottbund, 2x Vollflansch, Haltering und Dichtung <i>bulkhead, 2x flange clamp, retaining and Bonded seal</i>	RRF-B-...	RRF-B-X-...
• Schottbund, 2x Vollflansch, Haltering, Dichtung + Schrauben <i>bulkhead, 2x flange clamp, retaining, Bonded seal + screws</i>	RRF-B-...M	RRF-B-X-...MX

S.A.E. Baugröße <i>nominal flange size</i>	Typ <i>type</i>					Gewicht <i>weight</i>
Inch		L	Benötigte Schottöffnung	Halteringflansche	Schottbund	kg
Hochdruckreihe / High pressure						
1/2"	RRF-B-601	170	27	RRF-6001	RRF-B-001	1,6
3/4"	RRF-B-602	170	37	RRF-6002	RRF-B-002	1,8
1"	RRF-B-603	170	40	RRF-6003	RRF-B-003	2,1
1 1/4"	RRF-B-604	180	47	RRF-6004	RRF-B-004	3
1 1/2"	RRF-B-605	180	57	RRF-6005	RRF-B-005	4,5
2"	RRF-B-606	210	68	RRF-6006	RRF-B-006	7

*1 oder vergleichbare Güte / or comparable material

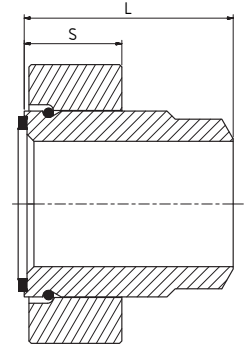
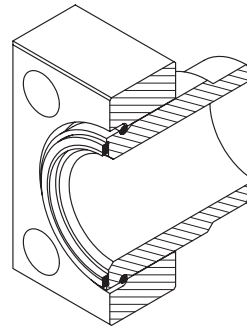

Bestellbezeichnung: ordering code:	S355J2^{*1}	1.4404^{*1}
<ul style="list-style-type: none"> • Haltering Vollflansch, Anschweißbund, Haltering und Dichtung <i>retain flange clamp, weld neck, retaining and Bonded seal</i> 	VKR-.../...	VKR-X-.../...
<ul style="list-style-type: none"> • Haltering Vollflansch, Anschweißbund, Haltering und Dichtung + Schrauben <i>retain flange clamp, weld neck, retaining and Bonded seal + screws</i> 	VKR-.../...M	VKR-X-.../...MX

Baugröße <i>nominal flange size</i>	Rohrmaß <i>pipe diameter</i>	Typ <i>type</i>					Gewicht <i>weight</i>
			L	S	Haltering Anschweißbund	Haltering Vollflansch	
Inch							kg
ISO6164							
1 1/2"	38x5	VKR-38/38x5	45	28	RRF-005-38x5	VKR-38	1,6
1 1/2"	48,3x2,8	VKR-38/48,3x2,8	45	28	RRF-005-48,3x2,8	VKR-38	1,6
1 1/2"	48,3x3,7	VKR-38/48,3x3,7	45	28	RRF-005-48,3x3,7	VKR-38	1,6
1 1/2"	48,3x5,1	VKR-38/48,3x5,1	45	28	RRF-005-48,3x5,1	VKR-38	1,6
1 1/2"	48,3x7,1	VKR-38/48,3x7,1	60	28	RRF-005-48,3x7,1	VKR-38	1,6
1 1/2"	48,3x10,2	VKR-38/48,3x10,2	60	28	RRF-005-48,3x10,2	VKR-38	1,6
1 1/2"	50x5	VKR-38/50x5	45	28	RRF-005-50x5	VKR-38	1,6
1 1/2"	50x6	VKR-38/50x6	45	28	RRF-005-50x6	VKR-38	1,6
1 1/2"	50x9	VKR-38/50x9	45	28	RRF-005-50x9	VKR-38	1,6
1 1/2"	56x8,5	VKR-38/56x8,5	60	28	RRF-005-56x8,5	VKR-38	1,7
2"	48,3x5,1	VKR-40/48,3x5,1	50	33	RRF-006-48,3x5,1	VKR-40	2,3
2"	50x9	VKR-40/50x9	50	33	RRF-006-50x9	VKR-40	2
2"	60x5	VKR-40/60x5	50	33	RRF-006-60x5	VKR-40	2,2
2"	60x6	VKR-40/60x6	50	33	RRF-006-60x6	VKR-40	2,3
2"	60x8	VKR-40/60x8	50	33	RRF-006-60x8	VKR-40	2,3
2"	60x10	VKR-40/60x10	50	33	RRF-006-60x10	VKR-40	2,3
2"	60,3x2,8	VKR-40/60,3x2,8	50	33	RRF-006-60,3x2,8	VKR-40	2,3
2"	60,3x3,9	VKR-40/60,3x3,9	50	33	RRF-006-60,3x3,9	VKR-40	2,3
2"	60,3x5,6	VKR-40/60,3x5,6	50	33	RRF-006-60,3x5,6	VKR-40	2,3
2"	60,3x8,8	VKR-40/60,3x8,8	75	33	RRF-006-60,3x8,8	VKR-40	2,5
2"	60,3x11,1	VKR-40/60,3x11,1	75	33	RRF-006-60,3x11,1	VKR-40	2,5
2"	66x8,5	VKR-40/66x8,5	75	33	RRF-006-66x8,5	VKR-40	2,5

Weitere Größen auf Anfrage

*1 oder vergleichbare Güte / or comparable material

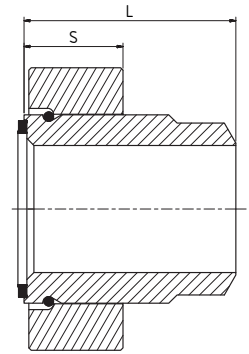
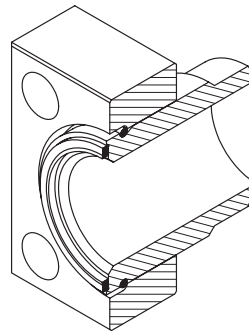

Bestellbezeichnung: ordering code:	S355J2*1	1.4404*1
<ul style="list-style-type: none"> • Haltering Vollflansch, Anschweißbund, Haltering und Dichtung <i>retain flange clamp, weld neck, retaining and Bonded seal</i> 	VKR-.../...	VKR-X-.../...
<ul style="list-style-type: none"> • Haltering Vollflansch, Anschweißbund, Haltering und Dichtung + Schrauben <i>retain flange clamp, weld neck, retaining and Bonded seal + screws</i> 	VKR-.../...M	VKR-X-.../...MX

Baugröße nominal flange size	Rohrmaß pipe diameter	Typ type					Gewicht weight
			L	S	Haltering Anschweißbund	Haltering Vollflansch	
ISO6164							
2 1/2"	65x8	VKR-50/65x8	50	43	RRF-007-65x8	VKR-50	3,2
2 1/2"	73x7	VKR-50/73x7	50	43	RRF-007-73x7	VKR-50	3,1
2 1/2"	73x9,5	VKR-50/73x9,5	90	43	RRF-007-73x9,5	VKR-50	3,3
2 1/2"	73x14	VKR-50/73x14	90	43	RRF-007-73x14	VKR-50	3,5
2 1/2"	75x5	VKR-50/75x5	50	43	RRF-007-75x5	VKR-50	3,3
2 1/2"	76,1x6,3	VKR-50/76,1x6,3	50	43	RRF-007-76,1x6,3	VKR-50	3
2 1/2"	76,1x12,5	VKR-50/76,1x12,5	50	43	RRF-007-76,1x12,5	VKR-50	3,3
2 1/2"	80x10	VKR-50/80x10	90	43	RRF-007-80x10	VKR-50	3,8
3"	76,1x12,5	VKR-65/76,1x12,5	60	56	RRF-008-76,1x12,5	VKR-65	5,6
3"	80x10	VKR-65/80x10	60	56	RRF-008-80x10	VKR-65	6
3"	88,9x3,2	VKR-65/88,9x3,2	60	56	RRF-008-88,9x3,2	VKR-65	6
3"	88,9x5,5	VKR-65/88,9x5,5	60	56	RRF-008-88,9x5,5	VKR-65	6
3"	88,9x7,6	VKR-65/88,9x7,6	110	56	RRF-008-88,9x7,6	VKR-65	6
3"	88,9x8,8	VKR-65/88,9x8,8	60	56	RRF-008-88,9x8,8	VKR-65	6,1
3"	88,9x11,1	VKR-65/88,9x11,1	110	56	RRF-008-88,9x11,1	VKR-65	6,3
3"	88,9x12,5	VKR-65/88,9x12,5	60	56	RRF-008-88,9x12,5	VKR-65	6,3
3"	88,9x15,3	VKR-65/88,9x15,3	110	56	RRF-008-88,9x15,3	VKR-65	6,5
3"	90x5	VKR-65/90x5	60	56	RRF-008-90x5	VKR-65	6,3
3"	97x12	VKR-65/97x12	110	56	RRF-008-97x12	VKR-65	7

Weitere Größen auf Anfrage

*1 oder vergleichbare Güte / or comparable material

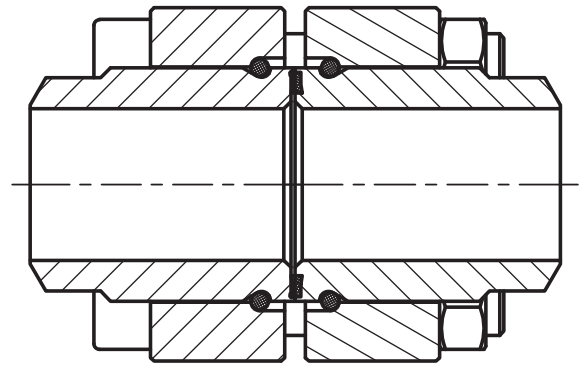

Bestellbezeichnung: ordering code:	S355J2^{*1}	1.4404^{*1}
• Vollflansch mit Bund, Haltering, Dichtung + Schrauben flange clamp with weld neck, retaining, Bonded seal + screws	VKRK-...-...M	VKRK-X-...-...MX

Baugröße nominal flange size	Rohrmaß pipe diameter	Typ type				Gewicht weight
			Halteringbund	Halteringgegenbund	Haltering Vollflansch	
Inch						kg
ISO6164						
1 1/2"	38x5	VKRK-38/38x5	RRF-005-38x5	GRRF-005-38x5	VKR-38	3,52
1 1/2"	48,3x2,8	VKRK-38/48,3x2,8	RRF-005-48,3x2,8	GRRF-005-48,3x2,8	VKR-38	3,52
1 1/2"	48,3x3,7	VKRK-38/48,3x3,7	RRF-005-48,3x3,7	GRRF-005-48,3x3,7	VKR-38	3,52
1 1/2"	48,3x5,1	VKRK-38/48,3x5,1	RRF-005-48,3x5,1	GRRF-005-48,3x5,1	VKR-38	3,52
1 1/2"	48,3x7,1	VKRK-38/48,3x7,1	RRF-005-48,3x7,1	GRRF-005-48,3x7,1	VKR-38	3,52
1 1/2"	48,3x10,2	VKRK-38/48,3x10,2	RRF-005-48,3x10,2	GRRF-005-48,3x10,2	VKR-38	3,52
1 1/2"	50x5	VKRK-38/50x5	RRF-005-50x5	GRRF-005-50x5	VKR-38	3,52
1 1/2"	50x6	VKRK-38/50x6	RRF-005-50x6	GRRF-005-50x6	VKR-38	3,52
1 1/2"	50x9	VKRK-38/50x9	RRF-005-50x9	GRRF-005-50x9	VKR-38	3,52
1 1/2"	56x8,5	VKRK-38/56x8,5	RRF-005-56x8,5	GRRF-005-56x8,5	VKR-38	3,74
2"	48,3x5,1	VKRK-40/48,3x5,1	RRF-006-48,3x5,1	GRRF-006-48,3x5,1	VKR-40	5,06
2"	50x9	VKRK-40/50x9	RRF-006-50x9	GRRF-006-50x9	VKR-40	4,4
2"	60x5	VKRK-40/60x5	RRF-006-60x5	GRRF-006-60x5	VKR-40	4,84
2"	60x6	VKRK-40/60x6	RRF-006-60x6	GRRF-006-60x6	VKR-40	5,06
2"	60x8	VKRK-40/60x8	RRF-006-60x8	GRRF-006-60x8	VKR-40	5,06
2"	60x10	VKRK-40/60x10	RRF-006-60x10	GRRF-006-60x10	VKR-40	5,06
2"	60,3x2,8	VKRK-40/60,3x2,8	RRF-006-60,3x2,8	GRRF-006-60,3x2,8	VKR-40	5,06
2"	60,3x3,9	VKRK-40/60,3x3,9	RRF-006-60,3x3,9	GRRF-006-60,3x3,9	VKR-40	5,06
2"	60,3x5,6	VKRK-40/60,3x5,6	RRF-006-60,3x5,6	GRRF-006-60,3x5,6	VKR-40	5,06
2"	60,3x8,8	VKRK-40/60,3x8,8	RRF-006-60,3x8,8	GRRF-006-60,3x8,8	VKR-40	5,5
2"	60,3x11,1	VKRK-40/60,3x11,1	RRF-006-60,3x11,1	GRRF-006-60,3x11,1	VKR-40	5,5
2"	66x8,5	VKRK-40/66x8,5	RRF-006-66x8,5	GRRF-006-66x8,5	VKR-40	5,5

Weitere Größen auf Anfrage

*1 oder vergleichbare Güte / or comparable material

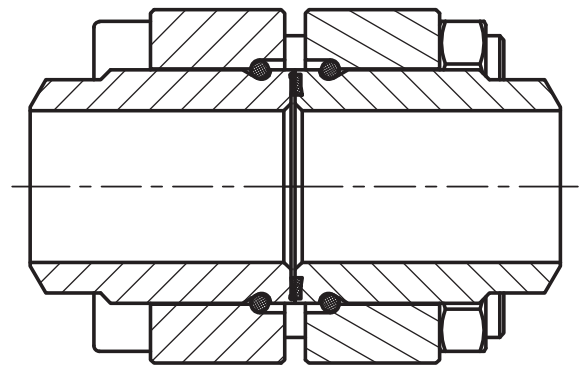

Bestellbezeichnung: ordering code:	S355J2^{*1}	1.4404^{*1}
• Vollflansch mit Bund, Haltering, Dichtung + Schrauben flange clamp with weld neck, retaining, Bonded seal + screws	VKRK-...-...M	VKRK-X-...-...MX

Baugröße nominal flange size	Rohrmaß pipe diameter	Typ type				Gewicht weight
			Halteringbund	Halteringgegenbund	Haltering Vollflansch	
Inch						kg
ISO6164						
2 1/2"	65x8	VKRK-50/65x8	RRF-007-65x8	GRRF-007-65x8	VKR-50	7,04
2 1/2"	73x7	VKRK-50/73x7	RRF-007-73x7	GRRF-007-73x7	VKR-50	6,82
2 1/2"	73x9,5	VKRK-50/73x9,5	RRF-007-73x9,5	GRRF-007-73x9,5	VKR-50	7,26
2 1/2"	73x14	VKRK-50/73x14	RRF-007-73x14	GRRF-007-73x14	VKR-50	7,7
2 1/2"	75x5	VKRK-50/75x5	RRF-007-75x5	GRRF-007-75x5	VKR-50	7,26
2 1/2"	76,1x6,3	VKRK-50/76,1x6,3	RRF-007-76,1x6,3	GRRF-007-76,1x6,3	VKR-50	6,6
2 1/2"	76,1x12,5	VKRK-50/76,1x12,5	RRF-007-76,1x12,5	GRRF-007-76,1x12,5	VKR-50	7,26
2 1/2"	80x10	VKRK-50/80x10	RRF-007-80x10	GRRF-007-80x10	VKR-50	8,36
3"	76,1x12,5	VKRK-65/76,1x12,5	RRF-008-76,1x12,5	GRRF-008-76,1x12,5	VKR-65	12,32
3"	80x10	VKRK-65/80x10	RRF-008-80x10	GRRF-008-80x10	VKR-65	13,2
3"	88,9x3,2	VKRK-65/88,9x3,2	RRF-008-88,9x3,2	GRRF-008-88,9x3,2	VKR-65	13,2
3"	88,9x5,5	VKRK-65/88,9x5,5	RRF-008-88,9x5,5	GRRF-008-88,9x5,5	VKR-65	13,2
3"	88,9x7,6	VKRK-65/88,9x7,6	RRF-008-88,9x7,6	GRRF-008-88,9x7,6	VKR-65	13,2
3"	88,9x8,8	VKRK-65/88,9x8,8	RRF-008-88,9x8,8	GRRF-008-88,9x8,8	VKR-65	13,42
3"	88,9x11,1	VKRK-65/88,9x11,1	RRF-008-88,9x11,1	GRRF-008-88,9x11,1	VKR-65	13,86
3"	88,9x12,5	VKRK-65/88,9x12,5	RRF-008-88,9x12,5	GRRF-008-88,9x12,5	VKR-65	13,86
3"	88,9x15,3	VKRK-65/88,9x15,3	RRF-008-88,9x15,3	GRRF-008-88,9x15,3	VKR-65	14,3
3"	90x5	VKRK-65/90x5	RRF-008-90x5	GRRF-008-90x5	VKR-65	13,86
3"	97x12	VKRK-65/97x12	RRF-008-97x12	GRRF-008-97x12	VKR-65	15,4

Weitere Größen auf Anfrage

*1 oder vergleichbare Güte / or comparable material

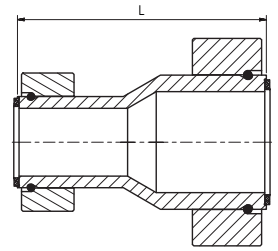
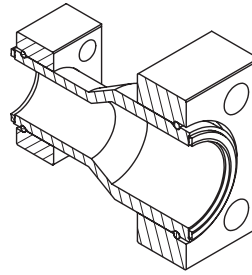

Bestellbezeichnung: ordering code:	S355J2^{*1}	1.4404^{*1}
<ul style="list-style-type: none"> • Reduzierbund, 2x Vollflansch, Haltering und Dichtung <i>reduction, 2x flange clamp, retaining and Bonded seal</i> • Reduzierbund, 2x Vollflansch, Haltering, Dichtung + Schrauben <i>reduction, 2x flange clamp, retaining, Bonded seal + screws</i> 	VKR-RED-...-...M	VKR-RED-X-...-...MX

Baugröße nominal flange size	Typ type	L	Halteringflansch 1	Halteringflansch 2	Reduzierbund	Gewicht weight
Inch						kg
ISO6164						
2" - 1½"	VKR-RED-40-38	130	VKR-40	VKR-38	RRF-RED-006-005	4,4
2½" - 2"	VKR-RED-50-40	150	VKR-50	VKR-40	RRF-RED-007-006	6
2½" - 1½"	VKR-RED-50-38	150	VKR-50	VKR-38	RRF-RED-007-005	5,5
3" - 2½"	VKR-RED-65-50	180	VKR-65	VKR-50	RRF-RED-008-007	10
3" - 2"	VKR-RED-65-40	180	VKR-65	VKR-40	RRF-RED-008-006	8,6

Weitere Größen auf Anfrage

*1 oder vergleichbare Güte / or comparable material

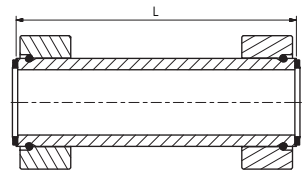
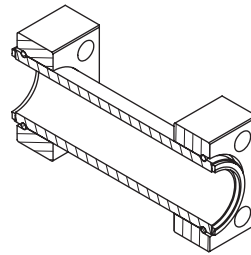
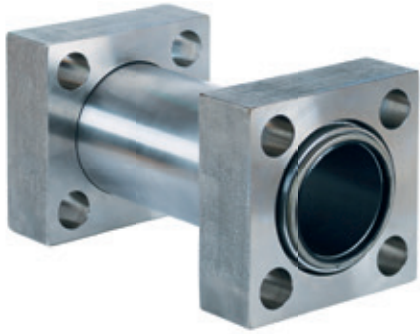

Bestellbezeichnung: ordering code:	S355J2^{*1}	1.4404^{*1}
• Schottbund, 2x Vollflansch, Haltering und Dichtung <i>bulkhead, 2x flange clamp, retaining and Bonded seal</i>	VKR-B-...	VKR-B-X-...
• Schottbund, 2x Vollflansch, Haltering, Dichtung + Schrauben <i>bulkhead, 2x flange clamp, retaining, Bonded seal + screws</i>	VKR-B-...M	VKR-B-X-...MX

Baugröße <i>nominal flange size</i>	Typ <i>type</i>					Gewicht <i>weight</i>
<i>Inch</i>		<i>L</i>	<i>Benötigte Schottöffnung</i>	<i>Haltering Vollflansch</i>	<i>Schottbund</i>	<i>kg</i>
ISO6164						
1½"	VKR-B-38	170	27	VKR-38	RRF-B-001	3,1
2"	VKR-B-40	170	37	VKR-40	RRF-B-002	5,8
2½"	VKR-B-50	170	40	VKR-50	RRF-B-003	8,2
3"	VKR-B-65	180	47	VKR-65	RRF-B-004	14

Weitere Größen auf Anfrage

*1 oder vergleichbare Güte / or comparable material



Bestellbezeichnung: ordering code:	1.4404
• nur Haltering	RETAINRING-...

S.A.E. Baugröße nominal flange size	Typ type	Rohrmaß pipe diameter	Abmessungen dimensions	
			D	S
inch				
1/2"	Retainring-1/2"	26x6	30	4
3/4"	Retainring-3/4"	36x8	40	4
1"	Retainring-1"	39x7,5	44	5
1 1/4"	Retainring-1 1/4"	46x8	51	5
1 1/2"	Retainring-1 1/2"	56x8,5	61	5
2"	Retainring-2"	66x8,5	71	5
2 1/2"	Retainring-2 1/2"	80x10	85	5
3"	Retainring-3"	97x12	103	6
4"	Retainring-4"	115x15	123	8

Weitere Größen auf Anfrage

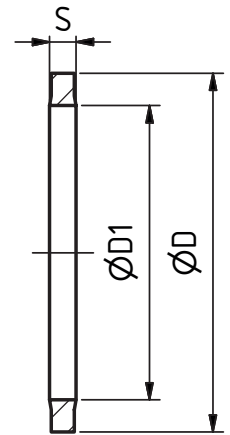
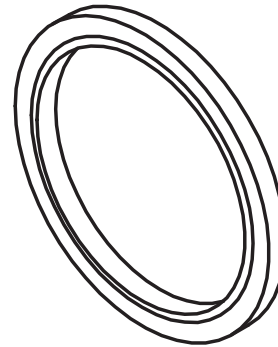

Bestellbezeichnung: ordering code:	Stahl + NBR70 1.4401xNBR70
• nur Verbunddichtung	BOND-...

S.A.E. Baugröße nominal flange size	Typ type	Abmessungen dimensions		
		D1	D	S
inch				
1/2"	Bond-1/2"	17,3	23,8	2,03
3/4"	Bond-3/4"	24,3	33,3	2,35
1"	Bond-1"	27,1	34,9	2,35
1 1/4"	Bond-1 1/4"	33,9	42,8	3,25
1 1/2"	Bond-1 1/2"	42,9	52,4	3,25
2"	Bond-2"	51,7	63,5	3,25
2 1/2"	Bond-2 1/2"	64,4	75,0	3,25
3"	Bond-3"	76,1	90,2	3,25
4"	Bond-4"	95	110,0	4

Weitere Größen auf Anfrage

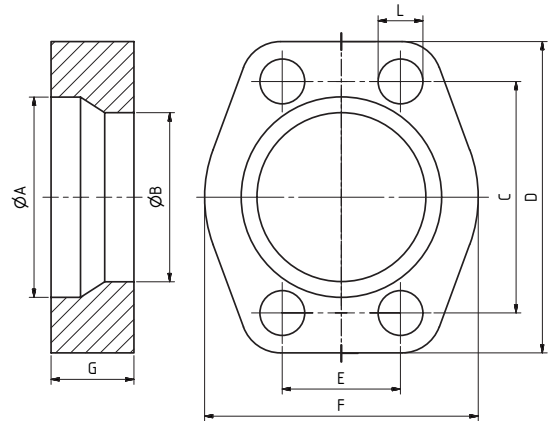

Bestellbezeichnung: ordering code:	S355J2^{*1}	1.4404^{*1}
• nur Bördelvollflansch only flange	FF-...	FF-X-...

S.A.E. Baugröße nominal flange size	Rohrmaß pipe diameter	Typ type	Abmessungen dimensions								Schrauben bolts		Gewicht weight	
			A	B	C	D	E	F	G	L	metr.			
kg/cm ²	inch													
Standarddruckreihe / Standard pressure											metr.			
												Einzel single	(Kupplung coupling)	
350	1/2"	FF-3001	30,5	26	38,1	54	17,5	46	20	9		M8x40 (60)		0,17
350	3/4"	FF-3002	38,5	31	47,6	65	22,2	52,3	20	11		M10x40 (60)		0,23
350	1"	FF-3003	45,5	39	52,4	70	26,2	58,7	20	11		M10x40 (60)		0,27
280	1 1/4"	FF-3004	50,5	43	58,7	79,4	30,2	73,2	20	11		M10x40 (70)		0,39
280	1 1/2"	FF-3005	60,5	51	69,9	94	35,7	82,6	25	13,5		M12x45 (80)		0,65
280	2"	FF-3006	70,5	61	77,8	102,1 *2	42,9	96,8	30	13,5		M12x50 (80)		0,98
210	2 1/2"	FF-3007	84,6	76	88,9	114,3	50,8	108,7	40	13,5		M12x60 (110)		1,49
210	3"	FF-3008	102,1	91	106,4	135	61,9	131,1	50	17,5		M16x80 (130)		2,52

*1 oder vergleichbare Güte / or comparable material
Oberfläche : CR-6 frei / surface CR-6 free

*2 Maß D bei 1.4404: 112,8 mm

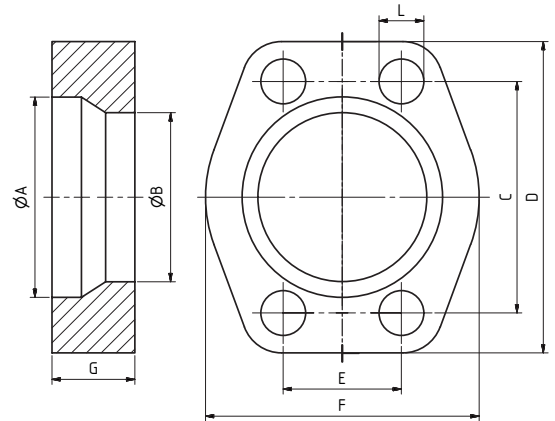

Bestellbezeichnung: ordering code:	S355J2^{*1}	1.4404^{*1}
• nur Bördelvollflansch only flange	FF-...	FF-X-...

S.A.E. Baugröße nominal flange size	Rohrmaß pipe diameter	Typ type	Abmessungen dimensions								Schrauben bolts		Gewicht weight	
			A	B	C	D	E	F	G	L	metr.			
kg/cm ²	inch													
Hochdruckreihe / High pressure											metr.			
												Einzel single	(Kupplung coupling)	
420	1/2"	FF-6001	30,5	26	40,5	56	18,2	47,8	22	9		M8x40 (65)	0,2	
420	3/4"	FF-6002	38,5	31	50,8	71	23,8	60,5	23	11		M10x40 (70)	0,42	
420	1"	FF-6003	45,5	39	57,2	81	27,8	69,9	25	13,5		M12x45 (75)	0,51	
420	1 1/4"	FF-6004	50,5	43	66,7	95	31,8	77,7	30	15		M14x50 (90)	0,86	
420	1 1/4"	FF-6044	50,5	43	66,7	95	31,8	77,7	30	13,3		M12x50 (90)	0,9	
420	1 1/2"	FF-6005	61,5	56,5	79,4	113	36,5	95,3	33	17,5		M16x60 (100)	1,45	
420	2"	FF-6006	71,5	66,5	96,8	133	44,5	114,3	38	21		M20x70 (110)	2,35	

*1 oder vergleichbare Güte / or comparable material
Oberfläche : CR-6 frei / surface CR-6 free

*2 Maß D bei 1.4404: 112,8 mm

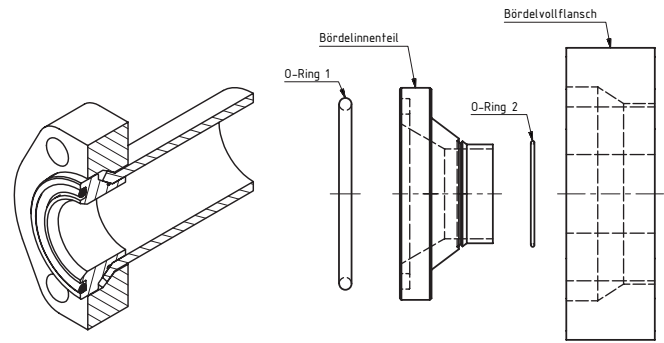

Bestellbezeichnung: ordering code:	S355J2^{*1}	1.4404^{*1}
• nur Bördelvollflansch only flange	FF-...	FF-X-...
• nur Bördelinnteil only flare flange	FFA-0...-...	FFA-X-0...
• Bördelvollflansch, Bördelteil und 2x O-Ring (Bördelhaltehülse) flange, flare flange and 2 x o-ring (flare shell)	FFA-...-...	FFA-X-...-...

S.A.E. Baugröße nominal flange size	Rohrmaß pipe diameter	Flansch Typ flange type	Einzelteile individual parts					Gewicht weight
			Bördelinnteil	O-Ring 1	O-Ring 2	Bördelhaltehülse	Bördelvollflansch	
Inch								kg
Hochdruckreihe / High pressure								
1/2"	16x2,0	FFA-301-16x2	FFA-001-16x2	O-Ring-18,64x3,53	O-RING-12x1	HFF-001-16	FF-3001	0,22
1/2"	18x2,0	FFA-301-18x2	FFA-001-18x2	O-Ring-18,64x3,53	O-RING-14x1	HFF-001-18	FF-3001	0,22
1/2"	19,05x2,11	FFA-301-19,05x2,11	FFA-001-19,05x2,11	O-Ring-18,64x3,53	O-RING-14x1	-	FF-3001	0,22
1/2"	19,05x2,41	FFA-301-19,05x2,41	FFA-001-19,05x2,41	O-Ring-18,64x3,53	O-RING-14x1	-	FF-3001	0,22
1/2"	19,05x2,77	FFA-301-19,05x2,77	FFA-001-19,05x2,41	O-Ring-18,64x3,53	O-RING-14x1	-	FF-3001	0,22
1/2"	20x2,0	FFA-301-20x2	FFA-001-20x2	O-Ring-18,64x3,53	O-RING-16x1	HFF-001-20	FF-3001	0,22
1/2"	21,3x3,7	FFA-301-21,3x3,7	FFA-001-21,3x3,7	O-Ring-18,64x3,53	O-RING-14x1	-	FF-3001	0,22
1/2"	21,3x4,8	FFA-301-21,3x4,8	FFA-001-21,3x4,8	O-Ring-18,64x3,53	O-RING-14x1	-	FF-3001	0,22
1/2"	25x2,5	FFA-301-25x2,5	FFA-001-25x2,5	O-Ring-18,64x3,53	O-RING-20x1	-	FF-3001	0,22
1/2"	30x3,0	FFA-301-30x3	FFA-001-30x3	O-Ring-18,64x3,53	O-RING-20x1	-	FF-3001	0,22
3/4"	20x2,0	FFA-302-20x2	FFA-002-20x2	O-RING-25,0X3,53	O-RING-16x1	HFF-002-20	FF-3002	0,4
3/4"	20x2,5	FFA-302-20x2,5	FFA-002-20x2,5	O-RING-25,0X3,53	O-RING-15x1	HFF-002-20	FF-3002	0,3
3/4"	25x2,5	FFA-302-25x2,5	FFA-002-25x2,5	O-RING-25,0X3,53	O-RING-20x1	HFF-002-25	FF-3002	0,35
3/4"	25x3,0	FFA-302-25x3	FFA-002-25x3	O-RING-25,0X3,53	O-RING-19x1	HFF-002-25	FF-3002	0,35
3/4"	26,7x3,91	FFA-302-26,7x3,91	FFA-002-26,7x3,91	O-RING-25,0X3,53	O-RING-20x1	-	FF-3002	0,3
3/4"	26,7x5,56	FFA-302-26,7x5,56	FFA-002-26,7x5,56	O-RING-25,0X3,53	O-RING-16x1	-	FF-3002	0,3
3/4"	30x3,0	FFA-302-30x3	FFA-002-30x3	O-RING-25,0X3,53	O-RING-23x1	-	FF-3002	0,3
1"	25x2,5	FFA-303-25x2,5	FFA-003-25x2,5	O-RING-32,9X3,53	O-RING-20x1	HFF-003-25	FF-3003	0,5
1"	25x3,0	FFA-303-25x3	FFA-003-25x3	O-RING-32,9X3,53	O-RING-19x1	HFF-003-25	FF-3003	0,5
1"	30x3,0	FFA-303-30x3	FFA-003-30x3	O-RING-32,9X3,53	O-RING-23x1	HFF-003-30	FF-3003	0,45
1"	30x4,0	FFA-303-30x4	FFA-003-30x4	O-RING-32,9X3,53	O-RING-22x1	HFF-003-30	FF-3003	0,45
1"	33,4X3,38	FFA-303-33,4-3,38	FFA-003-33,4-3,38	O-RING-32,9X3,53	O-RING-25x1	-	FF-3003	0,5
1"	33,4X4,55	FFA-303-33,4-4,55	FFA-003-33,4-4,55	O-RING-32,9X3,53	O-RING-23x1	-	FF-3003	0,5
1"	38x4,0	FFA-303-38x4	FFA-003-38x4	O-RING-32,9X3,53	O-RING-30x1	-	FF-3003	0,4

*1 oder vergleichbare Güte / or comparable material

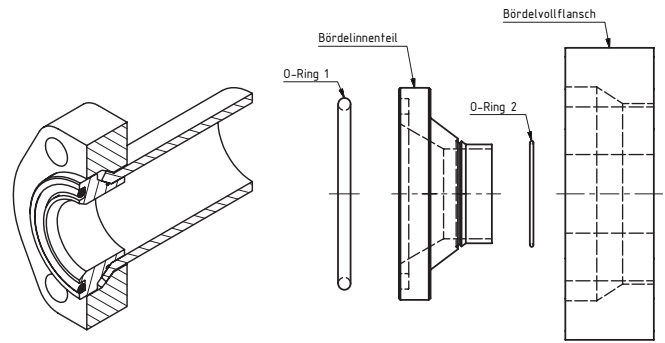

Bestellbezeichnung: ordering code:	S355J2^{*1}	1.4404^{*1}
• nur Bördelvollflansch only flange	FF-...	FF-X-...
• nur Bördelinnenteil only flare flange	FFA-0...-...	FFA-X-0...
• Bördelvollflansch, Bördelteil und 2x O-Ring (Bördelhaltehülse) flange, flare flange and 2 x o-ring (flare shell)	FFA-...-...	FFA-X-...-...

S.A.E. Baugröße nominal flange size	Rohrmaß pipe diameter	Flansch Typ flange type	Einzelteile individual parts					Gewicht weight
			Bördelinnenteil	O-Ring 1	O-Ring 2	Bördelhaltehülse	Bördelvollflansch	
Hochdruckreihe / High pressure								
1 1/4"	30x3,0	FFA-304-30x3	FFA-004-30x3	O-RING-37,7X3,53	O-RING-23x1	HFF-004-30	FF-3004	0,6
1 1/4"	30x4,0	FFA-304-30x4	FFA-004-30x4	O-RING-37,7X3,53	O-RING-22x1	HFF-004-30	FF-3004	0,5
1 1/4"	38x4,0	FFA-304-38x4	FFA-004-38x4	O-RING-37,7X3,53	O-RING-30x1	HFF-004-38	FF-3004	0,6
1 1/4"	38x5,0	FFA-304-38x5	FFA-004-38x5	O-RING-37,7X3,53	O-RING-28x1	HFF-004-38	FF-3004	0,55
1 1/4"	42x4,0	FFA-304-42x4	FFA-004-42x4	O-RING-37,7X3,53	O-RING-34x1	-	FF-3004	0,5
1 1/4"	42,2X3,56	FFA-304-42,4x3,56	FFA-004-42,4x3,56	O-RING-37,7X3,53	O-RING-34x1	-	FF-3004	0,6
1 1/4"	42,2X4,85	FFA-304-42,4x4,85	FFA-004-42,4x4,85	O-RING-37,7X3,53	O-RING-32x1	-	FF-3004	0,6
1 1/2"	30x3,0	FFA-305-30x3	FFA-005-30x3	O-Ring-47,2X3,53	O-RING-23x1	HFF-005-30	FF-3005	0,9
1 1/2"	38x4,0	FFA-305-38-4	FFA-005-38-4	O-RING-47,2X3,53	O-RING-30x1	HFF-005-38	FF-3005	1
1 1/2"	42x4,0	FFA-305-42-4	FFA-005-42-4	O-RING-47,2X3,53	O-RING-34x1	HFF-005-42	FF-3005	1
1 1/2"	48,3X3,68	FFA-305-48,3x3,68	FFA-005-48,3x3,68	O-RING-47,2X3,53	O-RING-41X1,78	-	FF-3005	0,9
1 1/2"	48,3X5,08	FFA-305-48,3x5,08	FFA-005-48,3x5,08	O-RING-47,2X3,53	O-RING-37,82X1,78	-	FF-3005	0,9
1 1/2"	50x5,0	FFA-305-50x5	FFA-005-50x5	O-RING-47,2X3,53	O-RING-41X1,78	-	FF-3005	0,9
2"	50x5,0	FFA-306-50x5	FFA-006-50x5	O-RING-56,7X3,53	O-RING-41X1,78	HFF-006-50	FF-3006	1,4
2"	60x5,0	FFA-306-60x5	FFA-006-60x5	O-RING-56,7X3,53	O-RING-50,52X1,78	-	FF-3006	1,25
2"	60x6,0	FFA-306-60x6	FFA-006-60x6	O-RING-56,7X3,53	O-RING-47,35X1,78	-	FF-3006	1,25
2"	60,3X3,91	FFA-306-60,3x3,91	FFA-006-60,3x3,91	O-RING-56,7X3,53	O-RING-50,52X1,78	-	FF-3006	1,4
2"	60,3X5,54	FFA-306x60,3x5,54	FFA-006x60,3x5,54	O-RING-56,7X3,53	O-RING-47,35X1,78	-	FF-3006	1,4
2 1/2"	60x5,0	FFA-307-60x5	FFA-007-60x5	O-RING-69,4X3,53	O-RING-50,52X1,78	HFF-007-60	FF-3007	2,1
2 1/2"	73x7,0	FFA-307-73x7	FFA-007-73x7	O-RING-69,4X3,53	O-RING-56,8x1,78	-	FF-3007	1,9
2 1/2"	73x5,16	FFA-307-73x5,16	FFA-007-73x5,16	O-RING-69,4X3,53	O-RING-63,22X1,78	-	FF-3007	1,9
2 1/2"	73x7,01	FFA-307-73x7,01	FFA-007-73x7,01	O-RING-69,4X3,53	O-RING-56,87X1,78	-	FF-3007	1,9
2 1/2"	75x5,0	FFA-307-75x5	FFA-007-75x5	O-RING-69,4X3,53	O-RING-63,22X1,78	-	FF-3007	1,9
3"	73x3,0	FFA-308-73x3	FFA-008-73x3	O-RING-85,3X3,53	O-RING-63,22X1,78	HFF-008-73	FF-3008	2,9
3"	88,9X5,49	FFA-308-88,9x5,49	FFA-008-88,9x5,49	O-RING-85,3X3,53	O-RING-79X1,78	-	FF-3008	3,1
3"	88,9X7,62	FFA-308-88,9x7,62	FFA-008-88,9x7,62	O-RING-85,3X3,53	O-RING-72,75X1,78	-	FF-3008	3,1
3"	90x5,0	FFA-308-90x5	FFA-008x90x5	O-RING-85,3X3,53	O-RING-79X1,78	-	FF-3008	3,1

*1 oder vergleichbare Güte / or comparable material

150 | SAE-Bördelflansch mit Dichtring Typ B - 3000 PSI – flach

SAE-flare flange with seal typ B

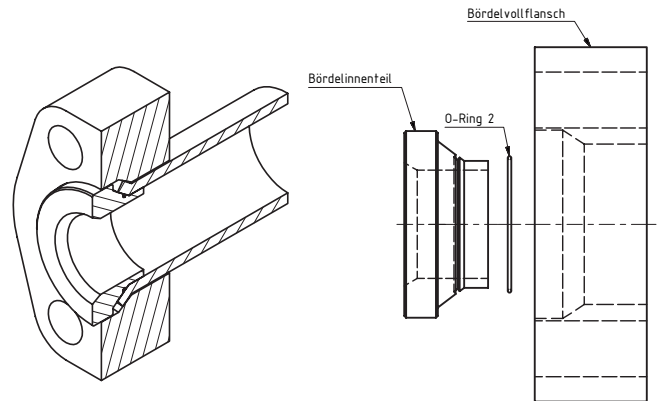

Bestellbezeichnung: ordering code:	S355J2^{*1}	1.4404^{*1}
• nur Bördelvollflansch only flange	FF-...	FF-X-...
• nur Bördelinnenteil only flare flange	FFB-0...-...	FFB-X-0...
• Bördelvollflansch, Bördelinnenteil und O-Ring (Bördelhaltehülse) flange, flare flange and o-ring (flare shell)	FFB-...-...	FFB-X-...-...

S.A.E. Baugröße nominal flange size	Rohrmaß pipe diameter	Typ type	Einzelteile individual parts				Gewicht weight
			Bördelinnenteil	O-Ring 2	Bördelhaltehülse	Bördel-vollflansch	
kg/cm ²							kg
1/2"	16x2,0	FFB-301-16x2	FFB-001-16x2	O-RING-12x1	HFF-001-16	FF-3001	0,22
1/2"	18x2,0	FFB-301-18x2	FFB-001-18x2	O-RING-14x1	HFF-001-18	FF-3001	0,22
1/2"	19,05x2,11	FFB-301-19,05x2,11	FFB-001-19,05x2,11	O-RING-14x1	-	FF-3001	0,22
1/2"	19,05x2,41	FFB-301-19,05x2,41	FFB-001-19,05x2,41	O-RING-14x1	-	FF-3001	0,22
1/2"	19,05x2,77	FFB-301-19,05x2,77	FFB-001-19,05x2,41	O-RING-14x1	-	FF-3001	0,22
1/2"	20x2,0	FFB-301-20x2	FFB-001-20x2	O-RING-16x1	HFF-001-20	FF-3001	0,22
1/2"	21,3x3,7	FFB-301-21,3x3,7	FFB-001-21,3x3,7	O-RING-14x1	-	FF-3001	0,22
1/2"	21,3x4,8	FFB-301-21,3x4,8	FFB-001-21,3x4,8	O-RING-14x1	-	FF-3001	0,22
1/2"	25x2,5	FFB-301-25x2,5	FFB-001-25x2,5	O-RING-20x1	-	FF-3001	0,22
1/2"	30x3,0	FFBA-301-30x3	FFB-001-30x3	O-RING-20x1	-	FF-3001	0,22
3/4"	20x2,0	FFB-302-20x2	FFB-002-20x2	O-RING-16x1	HFF-002-20	FF-3002	0,4
3/4"	20x2,5	FFB-302-20x2,5	FFB-002-20x2,5	O-RING-15x1	HFF-002-20	FF-3002	0,3
3/4"	25x2,5	FFB-302-25x2,5	FFB-002-25x2,5	O-RING-20x1	HFF-002-25	FF-3002	0,35
3/4"	25x3,0	FFB-302-25x3	FFB-002-25x3	O-RING-19x1	HFF-002-25	FF-3002	0,35
3/4"	26,7x3,91	FFB-302-26,7x3,91	FFB-002-26,7x3,91	O-RING-20x1	-	FF-3002	0,3
3/4"	26,7x5,56	FFB-302-26,7x5,56	FFB-002-26,7x5,56	O-RING-16x1	-	FF-3002	0,3
3/4"	30x3,0	FFB-302-30x3	FFB-002-30x3	O-RING-23x1	-	FF-3002	0,3
1"	25x2,5	FFB-303-25x2,5	FFB-003-25x2,5	O-RING-20x1	HFF-003-25	FF-3003	0,5
1"	25x3,0	FFB-303-25x3	FFB-003-25x3	O-RING-19x1	HFF-003-25	FF-3003	0,5
1"	30x3,0	FFB-303-30x3	FFB-003-30x3	O-RING-23x1	HFF-003-30	FF-3003	0,45
1"	30x4,0	FFB-303-30x4	FFB-003-30x4	O-RING-22x1	HFF-003-30	FF-3003	0,45
1"	33,4x3,38	FFB-303-33,4-3,38	FFB-003-33,4-3,38	O-RING-25x1	-	FF-3003	0,5
1"	33,4x4,55	FFB-303-33,4-4,55	FFB-003-33,4-4,55	O-RING-23x1	-	FF-3003	0,5
1"	38x4,0	FFB-303-38x4	FFB-003-38x4	O-RING-30x1	-	FF-3003	0,4

*1 oder vergleichbare Güte / or comparable material

151 | SAE-Bördelflansch mit Dichtring Typ B - 3000 PSI – flach

SAE-flare flange with seal typ B

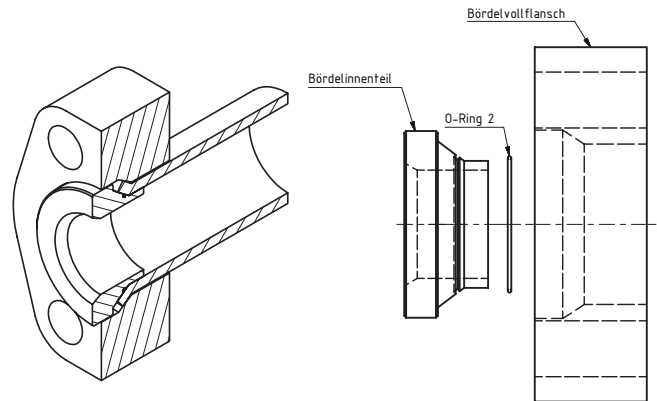

Bestellbezeichnung: ordering code:	S355J2^{*1}	1.4404^{*1}
• nur Bördelvollflansch <i>only flange</i>	FF-...	FF-X-...
• nur Bördelinnteil <i>only flare flange</i>	FFB-0...-...	FFB-X-0...
• Bördelvollflansch, Bördelinnteil und O-Ring (Bördelhaltehülse) <i>flange, flare flange and o-ring (flare shell)</i>	FFB-...-...	FFB-X-...-...

S.A.E. Baugröße <i>nominal flange size</i>	Rohrmaß <i>pipe diameter</i>	Typ <i>type</i>	Einzelteile <i>individual parts</i>				Gewicht <i>weight</i>
			Bördelinnteil	O-Ring 2	Bördelhaltehülse	Bördel-vollflansch	
kg/cm ²						kg	
1 1/4"	30x3,0	FFB-304-30x3	FFB-004-30x3	O-RING-23x1	HFF-004-30	FF-3004	0,6
1 1/4"	30x4,0	FFB-304-30x4	FFB-004-30x4	O-RING-22x1	HFF-004-30	FF-3004	0,5
1 1/4"	38x4,0	FFB-304-38x4	FFB-004-38x4	O-RING-30x1	HFF-004-38	FF-3004	0,6
1 1/4"	38x5,0	FFB-304-38x5	FFB-004-38x5	O-RING-28x1	HFF-004-38	FF-3004	0,55
1 1/4"	42x4,0	FFB-304-42x4	FFB-004-42x4	O-RING-34x1	-	FF-3004	0,5
1 1/4"	42,2X3,56	FFB-304-42,4x3,56	FFB-004-42,4x3,56	O-RING-34x1	-	FF-3004	0,6
1 1/4"	42,2X4,85	FFB-304-42,4x4,85	FFB-004-42,4x4,85	O-RING-32x1	-	FF-3004	0,6
1 1/2"	30x3,0	FFB-305-30x3	FFB-005-30x3	O-RING-23x1	HFF-005-30	FF-3005	0,9
1 1/2"	38x4,0	FFB-305-38-4	FFB-005-38-4	O-RING-30x1	HFF-005-38	FF-3005	1
1 1/2"	42x4,0	FFB-305-42-4	FFB-005-42-4	O-RING-34x1	HFF-005-42	FF-3005	1
1 1/2"	48,3X3,68	FFB-305-48,3x3,68	FFB-005-48,3x3,68	O-RING-41X1,78	-	FF-3005	0,9
1 1/2"	48,3X5,08	FFB-305-48,3x5,08	FFB-005-48,3x5,08	O-RING-37,82X1,78	-	FF-3005	0,9
1 1/2"	50x5,0	FFB-305-50x5	FFB-005-50x5	O-RING-41X1,78	-	FF-3005	0,9
2"	50x5,0	FFB-306-50x5	FFB-006-50x5	O-RING-41X1,78	HFF-006-50	FF-3006	1,4
2"	60x5,0	FFB-306-60x5	FFB-006-60x5	O-RING-50,52X1,78	-	FF-3006	1,25
2"	60x6,0	FFB-306-60x6	FFB-006-60x6	O-RING-47,35X1,78	-	FF-3006	1,25
2"	60,3X3,91	FFB-306-60,3x3,91	FFB-006-60,3x3,91	O-RING-50,52X1,78	-	FF-3006	1,4
2"	60,3X5,54	FFB-306x60,3x5,54	FFB-006x60,3x5,54	O-RING-47,35X1,78	-	FF-3006	1,4
2 1/2"	60x5,0	FFB-307-60x5	FFB-007-60x5	O-RING-50,52X1,78	HFF-007-60	FF-3007	2,1
2 1/2"	73x7,0	FFB-307-73x7	FFB-007-73x7	O-RING-56,8x1,78	-	FF-3007	1,9
2 1/2"	73x5,16	FFB-307-73x5,16	FFB-007-73x5,16	O-RING-63,22X1,78	-	FF-3007	1,9
2 1/2"	73x7,01	FFB-307-73x7,01	FFB-007-73x7,01	O-RING-56,87X1,78	-	FF-3007	1,9
2 1/2"	75x5,0	FFB-307-75x5	FFB-007-75x5	O-RING-63,22X1,78	-	FF-3007	1,9
3"	73x3,0	FFB-308-73x3	FFB-008-73x3	O-RING-63,22X1,78	HFF-008-73	FF-3008	2,9
3"	88,9X5,49	FFB-308-88,9x5,49	FFB-008-88,9x5,49	O-RING-79X1,78	-	FF-3008	3,1
3"	88,9X7,62	FFB-308-88,9x7,62	FFB-008-88,9x7,62	O-RING-72,75X1,78	-	FF-3008	3,1
3"	90x5,0	FFB-308-90x5	FFB-008x90x5	O-RING-79X1,78	-	FF-3008	3,1

*1 oder vergleichbare Güte / or comparable material

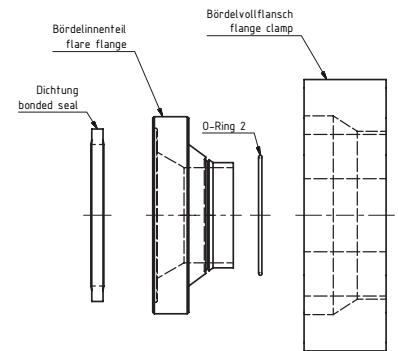
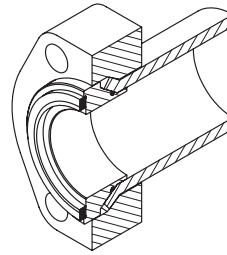

Bestellbezeichnung: ordering code:	S355J2^{*1}	1.4404^{*1}
• nur Bördevollflansch only flange	FF-...	FF-X-...
• nur Bördeleinenteil only flare flange	FFC-0...-...	FFC-X-0...
• Bördevollflansch, Bördeleinenteil, Dichtung und O-Ring (Bördelhaltehülse) flange, flare flange, bonded seal and o-ring (flare shell)	FFC-...-...	FFC-X-...-...

S.A.E. Baugröße nominal flange size	Rohrmaß pipe diameter	Flansch Typ flange type	Einzelteile individual parts					Gewicht weight
			Bördeleinenteil	Dichtung	O-Ring 2	Bördelhaltehülse	Bördevollflansch	
Standarddruckreihe / Standard pressure								
1/2"	16x2,0	FFC-301-16x2	FFC-001-16x2	Bond-1/2"	O-RING-12x1	HFF-001-16	FF-3001	0,22
1/2"	18x2,0	FFC-301-18x2	FFC-001-18x2	Bond-1/2"	O-RING-14x1	HFF-001-18	FF-3001	0,22
1/2"	19,05x2,11	FFC-301-19,05x2,11	FFC-001-19,05x2,11	Bond-1/2"	O-RING-14x1	-	FF-3001	0,22
1/2"	19,05x2,41	FFC-301-19,05x2,41	FFC-001-19,05x2,41	Bond-1/2"	O-RING-14x1	-	FF-3001	0,22
1/2"	19,05x2,77	FFC-301-19,05x2,77	FFC-001-19,05x2,41	Bond-1/2"	O-RING-14x1	-	FF-3001	0,22
1/2"	20x2,0	FFC-301-20x2	FFC-001-20x2	Bond-1/2"	O-RING-16x1	HFF-001-20	FF-3001	0,22
1/2"	21,3x3,7	FFC-301-21,3x3,7	FFC-001-21,3x3,7	Bond-1/2"	O-RING-14x1	-	FF-3001	0,22
1/2"	21,3x4,8	FFC-301-21,3x4,8	FFC-001-21,3x4,8	Bond-1/2"	O-RING-14x1	-	FF-3001	0,22
1/2"	25x2,5	FFC-301-25x2,5	FFC-001-25x2,5	Bond-1/2"	O-RING-20x1	-	FF-3001	0,22
1/2"	30x3,0	FFC-301-30x3	FFC-001-30x3	Bond-1/2"	O-RING-20x1	-	FF-3001	0,22
3/4"	20x2,0	FFC-302-20x2	FFC-002-20x2	Bond-3/4"	O-RING-16x1	HFF-002-20	FF-3002	0,4
3/4"	20x2,5	FFC-302-20x2,5	FFC-002-20x2,5	Bond-3/4"	O-RING-15x1	HFF-002-20	FF-3002	0,3
3/4"	25x2,5	FFC-302-25x2,5	FFC-002-25x2,5	Bond-3/4"	O-RING-20x1	HFF-002-25	FF-3002	0,35
3/4"	25x3,0	FFC-302-25x3	FFC-002-25x3	Bond-3/4"	O-RING-19x1	HFF-002-25	FF-3002	0,35
3/4"	26,7x3,91	FFC-302-26,7x3,91	FFC-002-26,7x3,91	Bond-3/4"	O-RING-20x1	-	FF-3002	0,3
3/4"	26,7x5,56	FFC-302-26,7x5,56	FFC-002-26,7x5,56	Bond-3/4"	O-RING-16x1	-	FF-3002	0,3
3/4"	30x3,0	FFC-302-30x3	FFC-002-30x3	Bond-3/4"	O-RING-23x1	-	FF-3002	0,3
1"	25x2,5	FFC-303-25x2,5	FFC-003-25x2,5	Bond-1"	O-RING-20x1	HFF-003-25	FF-3003	0,5
1"	25x3,0	FFC-303-25x3	FFC-003-25x3	Bond-1"	O-RING-19x1	HFF-003-25	FF-3003	0,5
1"	30x3,0	FFC-303-30x3	FFC-003-30x3	Bond-1"	O-RING-23x1	HFF-003-30	FF-3003	0,45
1"	30x4,0	FFC-303-30x4	FFC-003-30x4	Bond-1"	O-RING-22x1	HFF-003-30	FF-3003	0,45
1"	33,4x3,38	FFC-303-33,4-3,38	FFC-003-33,4-3,38	Bond-1"	O-RING-25x1	-	FF-3003	0,5
1"	33,4x4,55	FFC-303-33,4-4,55	FFC-003-33,4-4,55	Bond-1"	O-RING-23x1	-	FF-3003	0,5
1"	38x4,0	FFC-303-38x4	FFC-003-38x4	Bond-1"	O-RING-30x1	-	FF-3003	0,4

*1 oder vergleichbare Güte / or comparable material

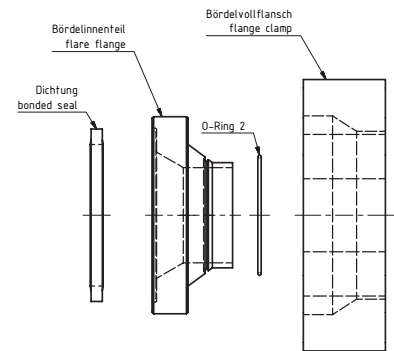
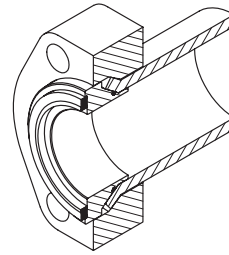

Bestellbezeichnung: ordering code:	S355J2^{*1}	1.4404^{*1}
• nur Bördelvollflansch only flange	FF-...	FF-X-...
• nur Bördelinnenteil only flare flange	FFC-0...-...	FFC-X-0...
• Bördelvollflansch, Bördelinnenteil, Dichtung und O-Ring (Bördelhaltehülse) flange, flare flange, bonded seal and o-ring (flare shell)	FFC-...-...	FFC-X-...-...

S.A.E. Baugröße nominal flange size	Rohrmaß pipe diameter	Flansch Typ flange type	Einzelteile individual parts					Gewicht weight kg
			Bördelinnenteil	Dichtung	O-Ring 2	Bördelhaltehülse	Bördelvollflansch	
Standarddruckreihe / Standard pressure								
1 1/4"	30x3,0	FFC-304-30x3	FFC-004-30x3	Bond-1.1/4"	O-RING-23x1	HFF-004-30	FF-3004	0,6
1 1/4"	30x4,0	FFC-304-30x4	FFC-004-30x4	tBond-1.1/4"	O-RING-22x1	HFF-004-30	FF-3004	0,5
1 1/4"	38x4,0	FFC-304-38x4	FFC-004-38x4	Bond-1.1/4"	O-RING-30x1	HFF-004-38	FF-3004	0,6
1 1/4"	38x5,0	FFC-304-38x5	FFC-004-38x5	Bond-1.1/4"	O-RING-28x1	HFF-004-38	FF-3004	0,55
1 1/4"	42x4,0	FFC-304-42x4	FFC-004-42x4	Bond-1.1/4"	O-RING-34x1	-	FF-3004	0,5
1 1/4"	42,2X3,56	FFC-304-42,4x3,56	FFC-004-42,4x3,56	Bond-1.1/4"	O-RING-34x1	-	FF-3004	0,6
1 1/4"	42,2X4,85	FFC-304-42,4x4,85	FFC-004-42,4x4,85	Bond-1.1/4"	O-RING-32x1	-	FF-3004	0,6
1 1/2"	30x3,0	FFC-305-30x3	FFC-005-30x3	Bond-1.1/2"	O-RING-23x1	HFF-005-30	FF-3005	0,9
1 1/2"	38x4,0	FFC-305-38-4	FFC-005-38-4	Bond-1.1/2"	O-RING-30x1	HFF-005-38	FF-3005	1
1 1/2"	42x4,0	FFC-305-42-4	FFC-005-42-4	Bond-1.1/2"	O-RING-34x1	HFF-005-42	FF-3005	1
1 1/2"	48,3X3,68	FFC-305-48,3x3,68	FFC-005-48,3x3,68	Bond-1.1/2"	O-RING-41X1,78	-	FF-3005	0,9
1 1/2"	48,3X5,08	FFC-305-48,3x5,08	FFC-005-48,3x5,08	Bond-1.1/2"	O-RING-37,82X1,78	-	FF-3005	0,9
1 1/2"	50x5,0	FFC-305-50x5	FFC-005-50x5	Bond-1.1/2"	O-RING-41X1,78	-	FF-3005	0,9
2"	50x5,0	FFC-306-50x5	FFC-006-50x5	Bond-2"	O-RING-41X1,78	HFF-006-50	FF-3006	1,4
2"	60x5,0	FFC-306-60x5	FFC-006-60x5	Bond-2"	O-RING-50,52X1,78	-	FF-3006	1,25
2"	60x6,0	FFC-306-60x6	FFC-006-60x6	Bond-2"	O-RING-47,35X1,78	-	FF-3006	1,25
2"	60,3X3,91	FFC-306-60,3x3,91	FFC-006-60,3x3,91	Bond-2"	O-RING-50,52X1,78	-	FF-3006	1,4
2"	60,3X5,54	FFC-306x60,3x5,54	FFC-006x60,3x5,54	Bond-2"	O-RING-47,35X1,78	-	FF-3006	1,4
2 1/2"	60x5,0	FFC-307-60x5	FFC-007-60x5	Bond-2.1/2"	O-RING-50,52X1,78	HFF-007-60	FF-3007	2,1
2 1/2"	73x7,0	FFC-307-73x7	FFC-007-73x7	Bond-2.1/2"	O-RING-56,8x1,78	-	FF-3007	1,9
2 1/2"	73x5,16	FFC-307-73x5,16	FFC-007-73x5,16	Bond-2.1/2"	O-RING-63,22X1,78	-	FF-3007	1,9
2 1/2"	73x7,01	FFC-307-73x7,01	FFC-007-73x7,01	Bond-2.1/2"	O-RING-56,87X1,78	-	FF-3007	1,9
2 1/2"	75x5,0	FFC-307-75x5	FFC-007-75x5	Bond-2.1/2"	O-RING-63,22X1,78	-	FF-3007	1,9
3"	73x3,0	FFC-308-73x3	FFC-008-73x3	Bond-3"	O-RING-63,22X1,78	HFF-008-73	FF-3008	2,9
3"	88,9X5,49	FFC-308-88,9x5,49	FFC-008-88,9x5,49	Bond-3"	O-RING-79X1,78	-	FF-3008	3,1
3"	88,9X7,62	FFC-308-88,9x7,62	FFC-008-88,9x7,62	Bond-3"	O-RING-72,75X1,78	-	FF-3008	3,1
3"	90x5,0	FFC-308-90x5	FFC-008x90x5	Bond-3"	O-RING-79X1,78	-	FF-3008	3,1

*1 oder vergleichbare Güte / or comparable material

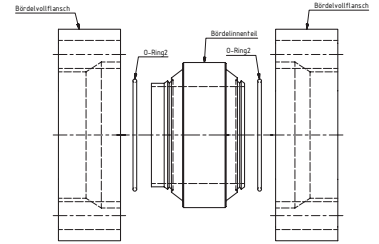
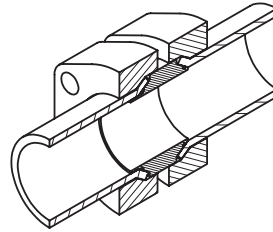

Bestellbezeichnung: ordering code:	S355J2^{*1}	1.4404^{*1}
• nur Bördelinnenteil only flare flange	FFD-0...-...	FFD-X-0...
• Bördelvollflansch, Bördelinnen- teil, O-Ring (Bördelhaltehülse), Schrauben und Mutter flange, flare flange, and o-ring (flare shell), Bolts and nuts	FFD-...-...M	FFD-X-...-...MX

S.A.E. Baugröße nominal flange size	Rohrmaß pipe diameter	Flansch Typ flange type	Einzelteile individual parts				Gewicht weight
			Bördelinnenteil	O-Ring 2	Bördelhaltehülse	Bördelvollflansch	
Inch							kg
Standarddruckreihe / Standard pressure							
1/2"	16x2,0	FFD-301-16x2	FFD-001-16x2	O-RING-12x1	HFF-001-16	FF-3001	0,44
1/2"	18x2,0	FFD-301-18x2	FFD-001-18x2	O-RING-14x1	HFF-001-18	FF-3001	0,44
1/2"	19,05x2,11	FFD-301-19,05x2,11	FFD-001-19,05x2,11	O-RING-14x1	-	FF-3001	0,44
1/2"	19,05x2,41	FFD-301-19,05x2,41	FFD-001-19,05x2,41	O-RING-14x1	-	FF-3001	0,44
1/2"	19,05x2,77	FFD-301-19,05x2,77	FFD-001-19,05x2,41	O-RING-14x1	-	FF-3001	0,44
1/2"	20x2,0	FFD-301-20x2	FFD-001-20x2	O-RING-16x1	HFF-001-20	FF-3001	0,44
1/2"	21,3x3,7	FFD-301-21,3x3,7	FFD-001-21,3x3,7	O-RING-14x1	-	FF-3001	0,44
1/2"	21,3x4,8	FFD-301-21,3x4,8	FFD-001-21,3x4,8	O-RING-14x1	-	FF-3001	0,44
1/2"	25x2,5	FFD-301-25x2,5	FFD-001-25x2,5	O-RING-20x1	-	FF-3001	0,44
1/2"	30x3,0	FFD-301-30x3	FFD-001-30x3	O-RING-20x1	-	FF-3001	0,44
3/4"	20x2,0	FFD-302-20x2	FFD-002-20x2	O-RING-16x1	HFF-002-20	FF-3002	0,8
3/4"	20x2,5	FFD-302-20x2,5	FFD-002-20x2,5	O-RING-15x1	HFF-002-20	FF-3002	0,6
3/4"	25x2,5	FFD-302-25x2,5	FFD-002-25x2,5	O-RING-20x1	HFF-002-25	FF-3002	0,7
3/4"	25x3,0	FFD-302-25x3	FFD-002-25x3	O-RING-19x1	HFF-002-25	FF-3002	0,7
3/4"	26,7x3,91	FFD-302-26,7x3,91	FFD-002-26,7x3,91	O-RING-20x1	-	FF-3002	0,6
3/4"	26,7x5,56	FFD-302-26,7x5,56	FFD-002-26,7x5,56	O-RING-16x1	-	FF-3002	0,6
3/4"	30x3,0	FFD-302-30x3	FFD-002-30x3	O-RING-23x1	-	FF-3002	0,6
1"	25x2,5	FFD-303-25x2,5	FFD-003-25x2,5	O-RING-20x1	HFF-003-25	FF-3003	1
1"	25x3,0	FFD-303-25x3	FFD-003-25x3	O-RING-19x1	HFF-003-25	FF-3003	1
1"	30x3,0	FFD-303-30x3	FFD-003-30x3	O-RING-23x1	HFF-003-30	FF-3003	0,9
1"	30x4,0	FFD-303-30x4	FFD-003-30x4	O-RING-22x1	HFF-003-30	FF-3003	0,9
1"	33,4x3,38	FFD-303-33,4-3,38	FFD-003-33,4-3,38	O-RING-25x1	-	FF-3003	1
1"	33,4x4,55	FFD-303-33,4-4,55	FFD-003-33,4-4,55	O-RING-23x1	-	FF-3003	1
1"	38x4,0	FFD-303-38x4	FFD-003-38x4	O-RING-30x1	-	FF-3003	0,8

*1 oder vergleichbare Güte / or comparable material

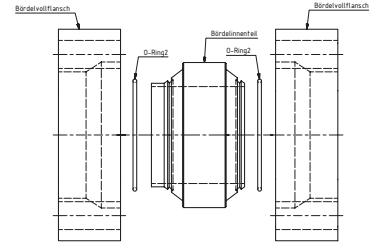
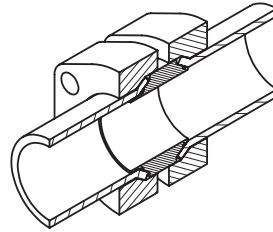

Bestellbezeichnung: ordering code:	S355J2^{*1}	1.4404^{*1}
• nur Bördelinnenteil only flare flange	FFD-0...-...	FFD-X-0...
• Bördelvollflansch, Bördelinnen- teil, O-Ring (Bördelhaltehülse), Schrauben und Mutter flange, flare flange, and o-ring (flare shell), Bolts and nuts	FFD-...-...M	FFD-X-...-...MX

S.A.E. Baugröße nominal flange size	Rohrmaß pipe diameter	Flansch Typ flange type	Einzelteile individual parts				Gewicht weight
			Bördelinnenteil	O-Ring 2	Bördelhaltehülse	Bördelvollflansch	
Inch							kg
Standarddruckreihe / Standard pressure							
1 1/4"	30x3,0	FFD-304-30x3	FFD-004-30x3	O-RING-23x1	HFF-004-30	FF-3004	1,2
1 1/4"	30x4,0	FFD-304-30x4	FFD-004-30x4	O-RING-22x1	HFF-004-30	FF-3004	1
1 1/4"	38x4,0	FFD-304-38x4	FFD-004-38x4	O-RING-30x1	HFF-004-38	FF-3004	1,2
1 1/4"	38x5,0	FFD-304-38x5	FFD-004-38x5	O-RING-28x1	HFF-004-38	FF-3004	1,1
1 1/4"	42x4,0	FFD-304-42x4	FFD-004-42x4	O-RING-34x1	-	FF-3004	1
1 1/4"	42,2X3,56	FFD-304-42,4x3,56	FFD-004-42,4x3,56	O-RING-34x1	-	FF-3004	1,2
1 1/4"	42,2X4,85	FFD-304-42,4x4,85	FFD-004-42,4x4,85	O-RING-32x1	-	FF-3004	1,2
1 1/2"	30x3,0	FFD-305-30x3	FFD-005-30x3	O-RING-23x1	HFF-005-30	FF-3005	1,8
1 1/2"	38x4,0	FFD-305-38-4	FFD-005-38-4	O-RING-30x1	HFF-005-38	FF-3005	2
1 1/2"	42x4,0	FFD-305-42-4	FFD-005-42-4	O-RING-34x1	HFF-005-42	FF-3005	2
1 1/2"	48,3X3,68	FFD-305-48,3x3,68	FFD-005-48,3x3,68	O-RING-41X1,78	-	FF-3005	1,8
1 1/2"	48,3X5,08	FFD-305-48,3x5,08	FFD-005-48,3x5,08	O-RING-37,82X1,78	-	FF-3005	1,8
1 1/2"	50x5,0	FFD-305-50x5	FFD-005-50x5	O-RING-41X1,78	-	FF-3005	1,8
2"	50x5,0	FFD-306-50x5	FFD-006-50x5	O-RING-41X1,78	HFF-006-50	FF-3006	2,8
2"	60x5,0	FFD-306-60x5	FFD-006-60x5	O-RING-50,52X1,78	-	FF-3006	2,5
2"	60x6,0	FFD-306-60x6	FFD-006-60x6	O-RING-47,35X1,78	-	FF-3006	2,5
2"	60,3X3,91	FFD-306-60,3x3,91	FFD-006-60,3x3,91	O-RING-50,52X1,78	-	FF-3006	2,8
2"	60,3X5,54	FFD-306x60,3x5,54	FFD-006x60,3x5,54	O-RING-47,35X1,78	-	FF-3006	2,8
2 1/2"	60x5,0	FFD-307-60x5	FFD-007-60x5	O-RING-50,52X1,78	HFF-007-60	FF-3007	4,2
2 1/2"	73x7,0	FFD-307-73x7	FFD-007-73x7	O-RING-56,8x1,78	-	FF-3007	3,8
2 1/2"	73x5,16	FFD-307-73x5,16	FFD-007-73x5,16	O-RING-63,22X1,78	-	FF-3007	3,8
2 1/2"	73x7,01	FFD-307-73x7,01	FFD-007-73x7,01	O-RING-56,87X1,78	-	FF-3007	3,8
2 1/2"	75x5,0	FFD-307-75x5	FFD-007-75x5	O-RING-63,22X1,78	-	FF-3007	3,8
3"	73x3,0	FFD-308-73x3	FFD-008-73x3	O-RING-63,22X1,78	HFF-008-73	FF-3008	5,8
3"	88,9X5,49	FFD-308-88,9x5,49	FFD-008-88,9x5,49	O-RING-79X1,78	-	FF-3008	6,2
3"	88,9X7,62	FFD-308-88,9x7,62	FFD-008-88,9x7,62	O-RING-72,75X1,78	-	FF-3008	6,2
3"	90x5,0	FFD-308-90x5	FFD-008x90x5	O-RING-79X1,78	-	FF-3008	6,2

*1 oder vergleichbare Güte / or comparable material

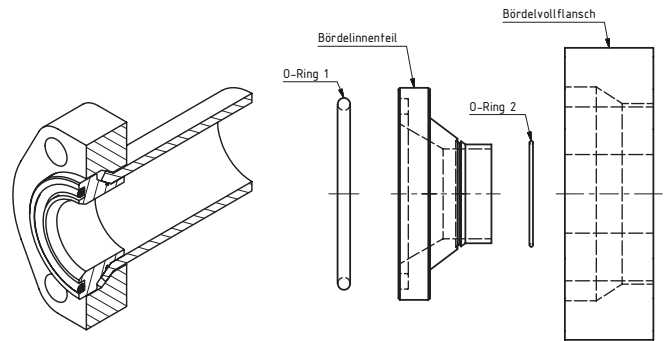

Bestellbezeichnung: ordering code:	S355J2^{*1}	1.4404^{*1}
• nur Bördevollflansch <i>only flange</i>	FF-...	FF-X-...
• nur Bördeinnenteil <i>only flare flange</i>	FFA-0.-...	FFA-X-0...
• Bördevollflansch, Bördeinnenteil und 2x O-Ring (Bördelhaltehülse) <i>flange, flare flange and 2 x o-ring (flare shell)</i>	FFA-...-...	FFA-X-...-...

S.A.E. Baugröße <i>nominal flange size</i>	Rohrmaß <i>pipe diameter</i>	Flansch Typ <i>flange type</i>	Einzelteile <i>individual parts</i>					Gewicht <i>weight</i>
			Bördeinnenteil	O-Ring 1	O-Ring 2	Bördelhaltehülse	Bördevollflansch	
Inch								kg
Hochdruckreihe / High pressure								
1/2"	16x2,0	FFA-601-16x2	FFA-001-16x2	O-Ring-18,64x3,53	O-RING-12x1	HFF-001-16	FF-6001	0,3
1/2"	18x2,0	FFA-601-18x2	FFA-001-18x2	O-Ring-18,64x3,53	O-RING-14x1	HFF-001-18	FF-6001	0,3
1/2"	20x2,0	FFA-601-20x2	FFA-001-20x2	O-Ring-18,64x3,53	O-RING-16x1	HFF-001-20	FF-6001	0,25
1/2"	21,3x3,7	FFA-601-21,3x3,7	FFA-001-21,3x3,7	O-Ring-18,64x3,53	O-RING-14x1	-	FF-6001	0,25
1/2"	21,3x4,8	FFA-601-21,3x4,8	FFA-001-21,3x4,8	O-Ring-18,64x3,53	O-RING-14x1	-	FF-6001	0,25
1/2"	25x2,5	FFA-601-25x2,5	FFA-001-25x2,5	O-Ring-18,64x3,53	O-RING-20x1	-	FF-6001	0,24
1/2"	25x3,0	FFA-601-25x3,0	FFA-001-25x3,0	O-Ring-18,64x3,53	O-RING-19x1	-	FF-6001	0,24
1/2"	30x3,0	FFA-601-30x3	FFA-001-30x3	O-Ring-18,64x3,53	O-RING-20x1	-	FF-6001	0,24
3/4"	20x2,0	FFA-602-20x2	FFA-002-20x2	O-RING-25,0X3,53	O-RING-16x1	HFF-002-20	FF-6002	0,4
3/4"	20x2,5	FFA-602-20x2,5	FFA-002-20x2,5	O-RING-25,0X3,53	O-RING-15x1	HFF-002-20	FF-6002	0,3
3/4"	25x2,5	FFA-602-25x2,5	FFA-002-25x2,5	O-RING-25,0X3,53	O-RING-20x1	HFF-002-25	FF-6002	0,35
3/4"	25x3,0	FFA-602-25x3	FFA-002-25x3	O-RING-25,0X3,53	O-RING-19x1	HFF-002-25	FF-6002	0,35
3/4"	26,7x3,9	FFA-602-26,7x3,9	FFA-002-26,7x3,9	O-RING-25,0X3,53	O-RING-20x1	-	FF-6002	0,3
3/4"	26,7x5,5	FFA-602-26,7x5,5	FFA-002-26,7x5,5	O-RING-25,0X3,53	O-RING-16x1	-	FF-6002	0,3
3/4"	30x3,0	FFA-602-30x3	FFA-002-30x3	O-RING-25,0X3,53	O-RING-23x1	-	FF-6002	0,3
1"	25x2,5	FFA-603-25x2,5	FFA-003-25x2,5	O-RING-32,9X3,53	O-RING-20x1	HFF-003-25	FF-6003	0,5
1"	25x3,0	FFA-603-25x3	FFA-003-25x3	O-RING-32,9X3,53	O-RING-19x1	HFF-003-25	FF-6003	0,5
1"	30x3,0	FFA-603-30x3	FFA-003-30x3	O-RING-32,9X3,53	O-RING-23x1	HFF-003-30	FF-6003	0,45
1"	30x4,0	FFA-603-30x4	FFA-003-30x4	O-RING-32,9X3,53	O-RING-22x1	HFF-003-30	FF-6003	0,45
1"	33,4X3,4	FFA-603-33,4-3,4	FFA-003-33,4-3,4	O-RING-32,9X3,53	O-RING-25x1	-	FF-6003	0,5
1"	33,4X4,5	FFA-603-33,4-4,5	FFA-003-33,4-4,5	O-RING-32,9X3,53	O-RING-23x1	-	FF-6003	0,5
1"	38x4,0	FFA-603-38x4	FFA-003-38x4	O-RING-32,9X3,53	O-RING-30x1	-	FF-6003	0,4

*1 oder vergleichbare Güte / or comparable material

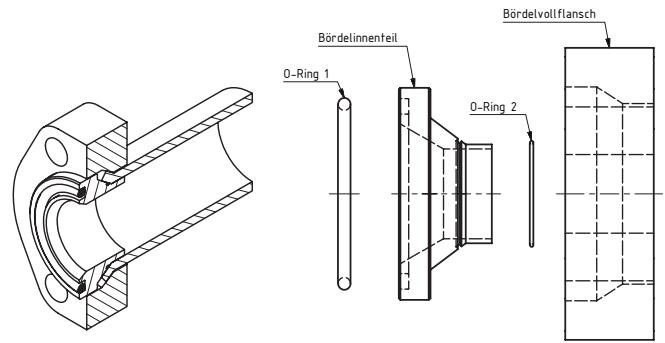

Bestellbezeichnung: ordering code:	S355J2*1	1.4404*1
• nur Bördevollflansch only flange	FF-...	FF-X-...
• nur Bördelinnenteil only flare flange	FFA-0.-...	FFA-X-0...
• Bördevollflansch, Bördelteil und 2x O-Ring (Bördelhaltehülse) flange, flare flange and 2 x o-ring (flare shell)	FFA-...-...	FFA-X-...-...

S.A.E. Baugröße nominal flange size	Rohrmaß pipe diameter	Flansch Typ flange type	Einzelteile individual parts					Gewicht weight
			Bördelteil	O-Ring 1	O-Ring 2	Bördelhaltehülse	Bördevollflansch	
Inch								kg
Hochdruckreihe / High pressure								
1 1/4"	30x3,0	FFA-604-30x3	FFA-004-30x3	O-RING-37,7X3,53	O-RING-23x1	HFF-004-30	FF-6004	0,6
1 1/4"	30x4,0	FFA-604-30x4	FFA-004-30x4	O-RING-37,7X3,53	O-RING-22x1	HFF-004-30	FF-6004	0,5
1 1/4"	38x4,0	FFA-604-38x4	FFA-004-38x4	O-RING-37,7X3,53	O-RING-30x1	HFF-004-38	FF-6004	0,6
1 1/4"	38x5,0	FFA-604-38x5	FFA-004-38x5	O-RING-37,7X3,53	O-RING-28x1	HFF-004-38	FF-6004	0,55
1 1/4"	42x4,0	FFA-604-42x4	FFA-004-42x4	O-RING-37,7X3,53	O-RING-34x1	-	FF-6004	0,5
1 1/4"	42,2X3,6	FFA-604-42,4x3,6	FFA-004-42,4x3,6	O-RING-37,7X3,53	O-RING-34x1	-	FF-6004	0,6
1 1/4"	42,2X4,8	FFA-604-42,4x4,8	FFA-004-42,4x4,8	O-RING-37,7X3,53	O-RING-32x1	-	FF-6004	0,6
1 1/2"	30x3,0	FFA-605-30x3	FFA-005-30x3	O-Ring-47,2X3,53	O-RING-23x1	HFF-005-30	FF-6005	0,9
1 1/2"	38x4,0	FFA-605-38-4	FFA-005-38-4	O-RING-47,2X3,53	O-RING-30x1	HFF-005-38	FF-6005	1
1 1/2"	42x4,0	FFA-605-42-4	FFA-005-42-4	O-RING-47,2X3,53	O-RING-34x1	HFF-005-42	FF-6005	1
1 1/2"	48,3X3,7	FFA-605-48,3x3,7	FFA-005-48,3x3,7	O-RING-47,2X3,53	O-RING-41X1,78	-	FF-6005	0,9
1 1/2"	48,3X5,1	FFA-605-48,3x5,1	FFA-005-48,3x5,1	O-RING-47,2X3,53	O-RING-37,82X1,78	-	FF-6005	0,9
1 1/2"	50x5,0	FFA-605-50x5	FFA-005-50x5	O-RING-47,2X3,53	O-RING-41X1,78	-	FF-6005	0,9
2"	50x5,0	FFA-606-50x5	FFA-006-50x5	O-RING-56,7X3,53	O-RING-41X1,78	HFF-006-50	FF-6006	1,4
2"	60x5,0	FFA-606-60x5	FFA-006-60x5	O-RING-56,7X3,53	O-RING-50,52X1,78	-	FF-6006	1,25
2"	60x6,0	FFA-606-60x6	FFA-006-60x6	O-RING-56,7X3,53	O-RING-47,35X1,78	-	FF-6006	1,25
2"	60,3X3,9	FFA-606-60,3x3,9	FFA-006-60,3x3,9	O-RING-56,7X3,53	O-RING-50,52X1,78	-	FF-6006	1,4
2"	60,3X5,5	FFA-606x60,3x5,5	FFA-006x60,3x5,5	O-RING-56,7X3,53	O-RING-47,35X1,78	-	FF-6006	1,4

*1 oder vergleichbare Güte / or comparable material

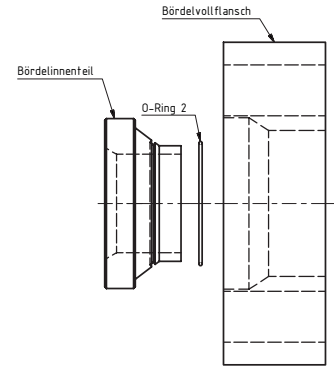
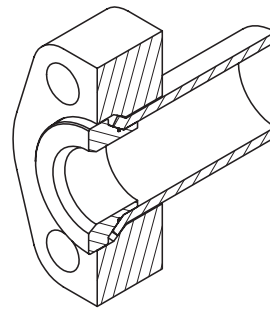

Bestellbezeichnung: ordering code:	S355J2^{*1}	1.4404^{*1}
• nur Bördelvollflansch only flange	FFD-0...-...	FFD-X-0...
• nur Bördelinnenteil only flare flange	FFD-...-...M	FFD-X-...-...MX
• Bördelvollflansch, Bördelinnenteil und O-Ring (Bördelhaltehülse) flange, flare flange and o-ring (flare shell)		

S.A.E. Baugröße nominal flange size	Rohrmaß pipe diameter	Flansch Typ flange type	Einzelteile individual parts				Gewicht weight
			Bördelteil	O-Ring 2	Bördelhaltehülse	Bördelvollflansch	
Inch							kg
Hochdruckreihe / High pressure							
1/2"	16x2,0	FFB-601-16x2	FFB-001-16x2	O-RING-12x1	HFF-001-16	FF-6001	0,3
1/2"	18x2,0	FFB-601-18x2	FFB-001-18x2	O-RING-14x1	HFF-001-18	FF-6001	0,3
1/2"	20x2,0	FFB-601-20x2	FFB-001-20x2	O-RING-16x1	HFF-001-20	FF-6001	0,25
1/2"	21,3x3,7	FFB-601-21,3x3,7	FFB-001-21,3x3,7	O-RING-14x1	-	FF-6001	0,25
1/2"	21,3x4,8	FFB-601-21,3x4,8	FFB-001-21,3x4,8	O-RING-14x1	-	FF-6001	0,25
1/2"	25x2,5	FFB-601-25x2,5	FFB-001-25x2,5	O-RING-20x1	-	FF-6001	0,24
1/2"	25x3,0	FFB-601-25x3,0	FFB-001-25x3,0	O-RING-19x1	-	FF-6001	0,24
1/2"	30x3,0	FFB-601-30x3	FFB-001-30x3	O-RING-20x1	-	FF-6001	0,24
3/4"	20x2,0	FFB-602-20x2	FFB-002-20x2	O-RING-16x1	HFF-002-20	FF-6002	0,4
3/4"	20x2,5	FFB-602-20x2,5	FFB-002-20x2,5	O-RING-15x1	HFF-002-20	FF-6002	0,3
3/4"	25x2,5	FFB-602-25x2,5	FFB-002-25x2,5	O-RING-20x1	HFF-002-25	FF-6002	0,35
3/4"	25x3,0	FFB-602-25x3	FFB-002-25x3	O-RING-19x1	HFF-002-25	FF-6002	0,35
3/4"	26,7x3,9	FFB-602-26,7x3,9	FFB-002-26,7x3,9	O-RING-20x1	-	FF-6002	0,3
3/4"	26,7x5,5	FFB-602-26,7x5,5	FFB-002-26,7x5,5	O-RING-16x1	-	FF-6002	0,3
3/4"	30x3,0	FFB-602-30x3	FFB-002-30x3	O-RING-23x1	-	FF-6002	0,3
1"	25x2,5	FFB-603-25x2,5	FFB-003-25x2,5	O-RING-20x1	HFF-003-25	FF-6003	0,5
1"	25x3,0	FFB-603-25x3	FFB-003-25x3	O-RING-19x1	HFF-003-25	FF-6003	0,5
1"	30x3,0	FFB-603-30x3	FFB-003-30x3	O-RING-23x1	HFF-003-30	FF-6003	0,45
1"	30x4,0	FFB-603-30x4	FFB-003-30x4	O-RING-22x1	HFF-003-30	FF-6003	0,45
1"	33,4x3,4	FFB-603-33,4-3,4	FFB-003-33,4-3,4	O-RING-25x1	-	FF-6003	0,5
1"	33,4x4,5	FFB-603-33,4-4,5	FFB-003-33,4-4,5	O-RING-23x1	-	FF-6003	0,5
1"	38x4,0	FFB-603-38x4	FFB-003-38x4	O-RING-30x1	-	FF-6003	0,4

*1 oder vergleichbare Güte / or comparable material

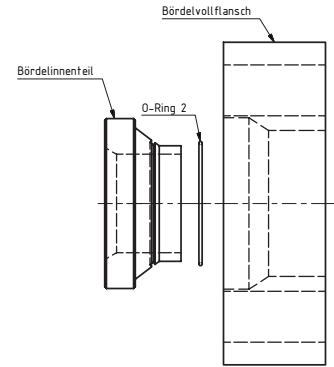
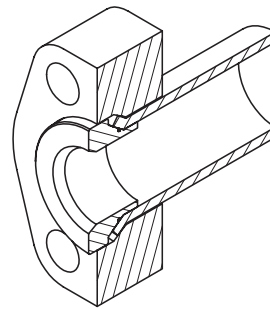

Bestellbezeichnung: ordering code:	S355J2^{*1}	1.4404^{*1}
• nur Bördelvollflansch only flange	FFD-0...-...	FFD-X-0...
• nur Bördelinnenteil only flare flange	FFD-...-...M	FFD-X-...-...MX
• Bördelvollflansch, Bördelinnenteil und O-Ring (Bördelhaltehülse) flange, flare flange and o-ring (flare shell)		

S.A.E. Baugröße nominal flange size	Rohrmaß pipe diameter	Flansch Typ flange type	Einzelteile individual parts				Gewicht weight
			Bördelteil	O-Ring 2	Bördelhaltehülse	Bördelvollflansch	
Inch							kg
Hochdruckreihe / High pressure							
1 1/4"	30x3,0	FFB-604-30x3	FFB-004-30x3	O-RING-23x1	HFF-004-30	FF-6004	0,6
1 1/4"	30x4,0	FFB-604-30x4	FFB-004-30x4	O-RING-22x1	HFF-004-30	FF-6004	0,5
1 1/4"	38x4,0	FFB-604-38x4	FFB-004-38x4	O-RING-30x1	HFF-004-38	FF-6004	0,6
1 1/4"	38x5,0	FFB-604-38x5	FFB-004-38x5	O-RING-28x1	HFF-004-38	FF-6004	0,55
1 1/4"	42x4,0	FFB-604-42x4	FFB-004-42x4	O-RING-34x1	-	FF-6004	0,5
1 1/4"	42,2X3,6	FFB-604-42,4x3,6	FFB-004-42,4x3,6	O-RING-34x1	-	FF-6004	0,6
1 1/4"	42,2X4,8	FFB-604-42,4x4,8	FFB-004-42,4x4,8	O-RING-32x1	-	FF-6004	0,6
1 1/2"	30x3,0	FFB-605-30x3	FFB-005-30x3	O-RING-23x1	HFF-005-30	FF-6005	0,9
1 1/2"	38x4,0	FFB-605-38-4	FFB-005-38-4	O-RING-30x1	HFF-005-38	FF-6005	1
1 1/2"	42x4,0	FFB-605-42-4	FFB-005-42-4	O-RING-34x1	HFF-005-42	FF-6005	1
1 1/2"	48,3X3,7	FFB-605-48,3x3,7	FFB-005-48,3x3,7	O-RING-41X1,78	-	FF-6005	0,9
1 1/2"	48,3X5,1	FFB-605-48,3x5,1	FFB-005-48,3x5,1	O-RING-37,82X1,78	-	FF-6005	0,9
1 1/2"	50x5,0	FFB-605-50x5	FFB-005-50x5	O-RING-41X1,78	-	FF-6005	0,9
2"	50x5,0	FFB-606-50x5	FFB-006-50x5	O-RING-41X1,78	HFF-006-50	FF-6006	1,4
2"	60x5,0	FFB-606-60x5	FFB-006-60x5	O-RING-50,52X1,78	-	FF-6006	1,25
2"	60x6,0	FFB-606-60x6	FFB-006-60x6	O-RING-47,35X1,78	-	FF-6006	1,25
2"	60,3X3,9	FFB-606-60,3x3,9	FFB-006-60,3x3,9	O-RING-50,52X1,78	-	FF-6006	1,4
2"	60,3X5,5	FFB-606x60,3x5,5	FFB-006x60,3x5,5	O-RING-47,35X1,78	-	FF-6006	1,4

*1 oder vergleichbare Güte / or comparable material

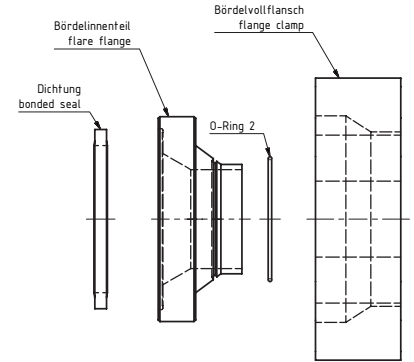
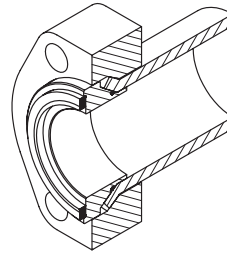

Bestellbezeichnung: ordering code:	S355J2^{*1}	1.4404^{*1}
• nur Bördelvollflansch only flange	FF-...	FF-X-...
• nur Bördelinnenteil only flare flange	FFC-0.-...	FFC-X-0...
• Bördelvollflansch, Bördel- innenteil, Dichtung und O-Ring (Bördelhaltehülse) flange, flare flange, bonded seal and o-ring (flare shell)	FFC-...-...	FFC-X-...-...

S.A.E. Baugröße nominal flange size	Rohrmaß pipe diameter	Typ type	Einzelteile individual parts					Gewicht weight
			Bördelinnenteil	Dichtung	O-Ring 2	Bördelhaltehülse	Bördelvollflansch	
Hochdruckreihe / High pressure								
1/2"	16x2,0	FFC-601-16x2	FFC-001-16x2	Bond-1/2"	O-RING-12x1	HFF-001-16	FF-6001	0,3
1/2"	18x2,0	FFC-601-18x2	FFC-001-18x2	Bond-1/2"	O-RING-14x1	HFF-001-18	FF-6001	0,3
1/2"	20x2,0	FFC-601-20x2	FFC-001-20x2	Bond-1/2"	O-RING-16x1	HFF-001-20	FF-6001	0,25
1/2"	21,3x3,7	FFC-601-21,3x3,7	FFC-001-21,3x3,7	Bond-1/2"	O-RING-14x1	-	FF-6001	0,25
1/2"	21,3x4,8	FFC-601-21,3x4,8	FFC-001-21,3x4,8	Bond-1/2"	O-RING-14x1	-	FF-6001	0,25
1/2"	25x2,5	FFC-601-25x2,5	FFC-001-25x2,5	Bond-1/2"	O-RING-20x1	-	FF-6001	0,24
1/2"	25x3,0	FFC-601-25x3,0	FFC-001-25x3,0	Bond-1/2"	O-RING-19x1	-	FF-6001	0,24
1/2"	30x3,0	FFC-601-30x3	FFC-001-30x3	Bond-1/2"	O-RING-20x1	-	FF-6001	0,24
3/4"	20x2,0	FFC-602-20x2	FFC-002-20x2	Bond-3/4"	O-RING-16x1	HFF-002-20	FF-6002	0,4
3/4"	20x2,5	FFC-602-20x2,5	FFC-002-20x2,5	Bond-3/4"	O-RING-15x1	HFF-002-20	FF-6002	0,3
3/4"	25x2,5	FFC-602-25x2,5	FFC-002-25x2,5	Bond-3/4"	O-RING-20x1	HFF-002-25	FF-6002	0,35
3/4"	25x3,0	FFC-602-25x3	FFC-002-25x3	Bond-3/4"	O-RING-19x1	HFF-002-25	FF-6002	0,35
3/4"	26,7x3,9	FFC-602-26,7x3,9	FFC-002-26,7x3,9	Bond-3/4"	O-RING-20x1	-	FF-6002	0,3
3/4"	26,7x5,5	FFC-602-26,7x5,5	FFC-002-26,7x5,5	Bond-3/4"	O-RING-16x1	-	FF-6002	0,3
3/4"	30x3,0	FFC-602-30x3	FFC-002-30x3	Bond-3/4"	O-RING-23x1	-	FF-6002	0,3
1"	25x2,5	FFC-603-25x2,5	FFC-003-25x2,5	Bond-1"	O-RING-20x1	HFF-003-25	FF-6003	0,5
1"	25x3,0	FFC-603-25x3	FFC-003-25x3	Bond-1"	O-RING-19x1	HFF-003-25	FF-6003	0,5
1"	30x3,0	FFC-603-30x3	FFC-003-30x3	Bond-1"	O-RING-23x1	HFF-003-30	FF-6003	0,45
1"	30x4,0	FFC-603-30x4	FFC-003-30x4	Bond-1"	O-RING-22x1	HFF-003-30	FF-6003	0,45
1"	33,4x3,4	FFC-603-33,4-3,4	FFC-003-33,4-3,4	Bond-1"	O-RING-25x1	-	FF-6003	0,5
1"	33,4x4,5	FFC-603-33,4-4,5	FFC-003-33,4-4,5	Bond-1"	O-RING-23x1	-	FF-6003	0,5
1"	38x4,0	FFC-603-38x4	FFC-003-38x4	Bond-1"	O-RING-30x1	-	FF-6003	0,4

*1 oder vergleichbare Güte / or comparable material

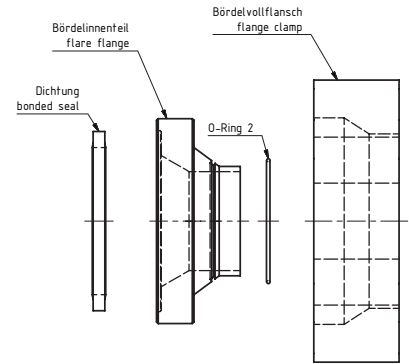
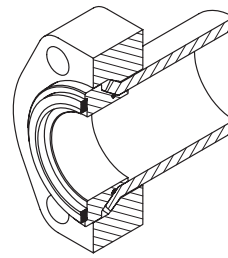

Bestellbezeichnung: ordering code:	S355J2^{*1}	1.4404^{*1}
• nur Bördelvollflansch only flange	FF-...	FF-X-...
• nur Bördelinnenteil only flare flange	FFC-0.-...	FFC-X-0...
• Bördelvollflansch, Bördel- innenteil, Dichtung und O-Ring (Bördelhaltehülse) flange, flare flange, bonded seal and o-ring (flare shell)	FFC-...-...	FFC-X-...-...

S.A.E. Baugröße nominal flange size	Rohrmaß pipe diameter	Typ type	Einzelteile individual parts					Gewicht weight
			Bördelinnenteil	Dichtung	O-Ring 2	Bördelhaltehülse	Bördelvollflansch	
Hochdruckreihe / High pressure								
1 1/4"	30x3,0	FFC-604-30x3	FFC-004-30x3	Bond-1.1/4"	O-RING-23x1	HFF-004-30	FF-6004	0,6
1 1/4"	30x4,0	FFC-604-30x4	FFC-004-30x4	Bond-1.1/4"	O-RING-22x1	HFF-004-30	FF-6004	0,5
1 1/4"	38x4,0	FFC-604-38x4	FFC-004-38x4	Bond-1.1/4"	O-RING-30x1	HFF-004-38	FF-6004	0,6
1 1/4"	38x5,0	FFC-604-38x5	FFC-004-38x5	Bond-1.1/4"	O-RING-28x1	HFF-004-38	FF-6004	0,55
1 1/4"	42x4,0	FFC-604-42x4	FFC-004-42x4	Bond-1.1/4"	O-RING-34x1	-	FF-6004	0,5
1 1/4"	42,2X3,6	FFC-604-42,4x3,6	FFC-004-42,4x3,6	Bond-1.1/4"	O-RING-34x1	-	FF-6004	0,6
1 1/4"	42,2X4,8	FFC-604-42,4x4,8	FFC-004-42,4x4,8	Bond-1.1/4"	O-RING-32x1	-	FF-6004	0,6
1 1/2"	30x3,0	FFC-605-30x3	FFC-005-30x3	Bond-1.1/2"	O-RING-23x1	HFF-005-30	FF-6005	0,9
1 1/2"	38x4,0	FFC-605-38-4	FFC-005-38-4	Bond-1.1/2"	O-RING-30x1	HFF-005-38	FF-6005	1
1 1/2"	42x4,0	FFC-605-42-4	FFC-005-42-4	Bond-1.1/2"	O-RING-34x1	HFF-005-42	FF-6005	1
1 1/2"	48,3X3,7	FFC-605-48,3x3,7	FFC-005-48,3x3,7	Bond-1.1/2"	O-RING-41X1,78	-	FF-6005	0,9
1 1/2"	48,3X5,1	FFC-605-48,3x5,1	FFC-005-48,3x5,1	Bond-1.1/2"	O-RING-37,82X1,78	-	FF-6005	0,9
1 1/2"	50x5,0	FFC-605-50x5	FFC-005-50x5	Bond-1.1/2"	O-RING-41X1,78	-	FF-6005	0,9
2"	50x5,0	FFC-606-50x5	FFC-006-50x5	Bond-2"	O-RING-41X1,78	HFF-006-50	FF-6006	1,4
2"	60x5,0	FFC-606-60x5	FFC-006-60x5	Bond-2"	O-RING-50,52X1,78	-	FF-6006	1,25
2"	60x6,0	FFC-606-60x6	FFC-006-60x6	Bond-2"	O-RING-47,35X1,78	-	FF-6006	1,25
2"	60,3X3,9	FFC-606-60,3x3,9	FFC-006-60,3x3,9	Bond-2"	O-RING-50,52X1,78	-	FF-6006	1,4
2"	60,3X5,5	FFC-606x60,3x5,5	FFC-006x60,3x5,5	Bond-2"	O-RING-47,35X1,78	-	FF-6006	1,4

*1 oder vergleichbare Güte / or comparable material

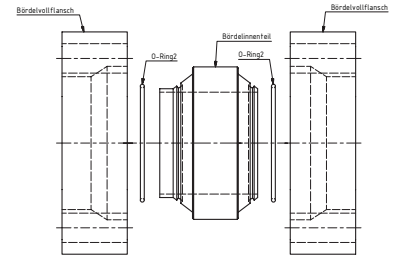
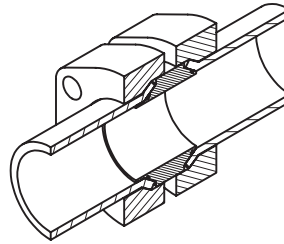

Bestellbezeichnung: ordering code:	S355J2^{*1}	1.4404^{*1}
• nur Bördelinnenteil only flare flange	FFD-0...-...	FFD-X-0...
• Bördelvollflansch, Bördelinnen- teil, O-Ring (Bördelhaltehülse), Schrauben und Mutter flange, flare flange, and o-ring (flare shell), Bolts and nuts	FFD-...-...M	FFD-X-...-...MX

S.A.E. Baugröße nominal flange size	Rohrmaß pipe diameter	Flansch Typ flange type	Einzelteile individual parts				Gewicht weight
			Bördelinnenteil	O-Ring 2	Bördelhaltehülse	Bördelvollflansch	
Inch							kg
Standarddruckreihe / Standard pressure							
1/2"	16x2,0	FFD-601-16x2	FFD-001-16x2	O-RING-12x1	HFF-001-16	FF-6001	0,44
1/2"	18x2,0	FFD-601-18x2	FFD-001-18x2	O-RING-14x1	HFF-001-18	FF-6001	0,44
1/2"	19,05x2,11	FFD-601-19,05x2,11	FFD-001-19,05x2,11	O-RING-14x1	-	FF-6001	0,44
1/2"	19,05x2,41	FFD-601-19,05x2,41	FFD-001-19,05x2,41	O-RING-14x1	-	FF-6001	0,44
1/2"	19,05x2,77	FFD-601-19,05x2,77	FFD-001-19,05x2,41	O-RING-14x1	-	FF-6001	0,44
1/2"	20x2,0	FFD-601-20x2	FFD-001-20x2	O-RING-16x1	HFF-001-20	FF-6001	0,44
1/2"	21,3x3,7	FFD-601-21,3x3,7	FFD-001-21,3x3,7	O-RING-14x1	-	FF-6001	0,44
1/2"	21,3x4,8	FFD-601-21,3x4,8	FFD-001-21,3x4,8	O-RING-14x1	-	FF-6001	0,44
1/2"	25x2,5	FFD-601-25x2,5	FFD-001-25x2,5	O-RING-20x1	-	FF-6001	0,44
1/2"	30x3,0	FFD-601-60x3	FFD-001-30x3	O-RING-20x1	-	FF-6001	0,44
3/4"	20x2,0	FFD-602-20x2	FFD-002-20x2	O-RING-16x1	HFF-002-20	FF-6002	0,8
3/4"	20x2,5	FFD-602-20x2,5	FFD-002-20x2,5	O-RING-15x1	HFF-002-20	FF-6002	0,6
3/4"	25x2,5	FFD-602-25x2,5	FFD-002-25x2,5	O-RING-20x1	HFF-002-25	FF-6002	0,7
3/4"	25x3,0	FFD-602-25x3	FFD-002-25x3	O-RING-19x1	HFF-002-25	FF-6002	0,7
3/4"	26,7x3,91	FFD-602-26,7x3,91	FFD-002-26,7x3,91	O-RING-20x1	-	FF-6002	0,6
3/4"	26,7x5,56	FFD-602-26,7x5,56	FFD-002-26,7x5,56	O-RING-16x1	-	FF-6002	0,6
3/4"	30x3,0	FFD-602-60x3	FFD-002-30x3	O-RING-23x1	-	FF-6002	0,6
1"	25x2,5	FFD-603-25x2,5	FFD-003-25x2,5	O-RING-20x1	HFF-003-25	FF-6003	1
1"	25x3,0	FFD-603-25x3	FFD-003-25x3	O-RING-19x1	HFF-003-25	FF-6003	1
1"	30x3,0	FFD-603-60x3	FFD-003-30x3	O-RING-23x1	HFF-003-30	FF-6003	0,9
1"	30x4,0	FFD-603-60x4	FFD-003-30x4	O-RING-22x1	HFF-003-30	FF-6003	0,9
1"	33,4x3,38	FFD-603-33,4-3,38	FFD-003-33,4-3,38	O-RING-25x1	-	FF-6003	1
1"	33,4x4,55	FFD-603-33,4-4,55	FFD-003-33,4-4,55	O-RING-23x1	-	FF-6003	1
1"	38x4,0	FFD-603-38x4	FFD-003-38x4	O-RING-30x1	-	FF-6003	0,8

*1 oder vergleichbare Güte / or comparable material

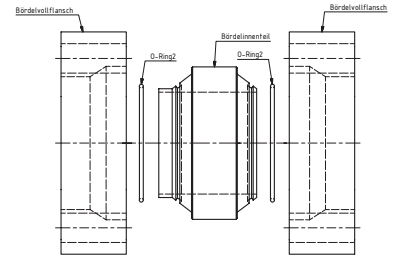
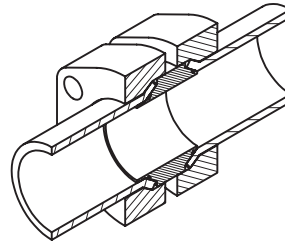

Bestellbezeichnung: ordering code:	S355J2^{*1}	1.4404^{*1}
• nur Bördelinnenteil only flare flange	FFD-0...-...	FFD-X-0...
• Bördelvollflansch, Bördelinnen- teil, O-Ring (Bördelhaltehülse), Schrauben und Mutter flange, flare flange, and o-ring (flare shell), Bolts and nuts	FFD-...-...M	FFD-X-...-...MX

S.A.E. Baugröße nominal flange size	Rohrmaß pipe diameter	Flansch Typ flange type	Einzelteile individual parts				Gewicht weight
			Bördelinnenteil	O-Ring 2	Bördelhaltehülse	Bördelvollflansch	
Standarddruckreihe / Standard pressure							
1 1/4"	30x3,0	FFD-604-60x3	FFD-004-30x3	O-RING-23x1	HFF-004-30	FF-6004	1,2
1 1/4"	30x4,0	FFD-604-60x4	FFD-004-30x4	O-RING-22x1	HFF-004-30	FF-6004	1
1 1/4"	38x4,0	FFD-604-38x4	FFD-004-38x4	O-RING-30x1	HFF-004-38	FF-6004	1,2
1 1/4"	38x5,0	FFD-604-38x5	FFD-004-38x5	O-RING-28x1	HFF-004-38	FF-6004	1,1
1 1/4"	42x4,0	FFD-604-42x4	FFD-004-42x4	O-RING-34x1	-	FF-6004	1
1 1/4"	42,2X3,56	FFD-604-42,4x3,56	FFD-004-42,4x3,56	O-RING-34x1	-	FF-6004	1,2
1 1/4"	42,2X4,85	FFD-604-42,4x4,85	FFD-004-42,4x4,85	O-RING-32x1	-	FF-6004	1,2
1 1/2"	30x3,0	FFD-605-60x3	FFD-005-30x3	O-RING-23x1	HFF-005-30	FF-6005	1,8
1 1/2"	38x4,0	FFD-605-38-4	FFD-005-38-4	O-RING-30x1	HFF-005-38	FF-6005	2
1 1/2"	42x4,0	FFD-605-42-4	FFD-005-42-4	O-RING-34x1	HFF-005-42	FF-6005	2
1 1/2"	48,3X3,68	FFD-605-48,3x3,68	FFD-005-48,3x3,68	O-RING-41X1,78	-	FF-6005	1,8
1 1/2"	48,3X5,08	FFD-605-48,3x5,08	FFD-005-48,3x5,08	O-RING-37,82X1,78	-	FF-6005	1,8
1 1/2"	50x5,0	FFD-605-50x5	FFD-005-50x5	O-RING-41X1,78	-	FF-6005	1,8
2"	50x5,0	FFD-606-50x5	FFD-006-50x5	O-RING-41X1,78	HFF-006-50	FF-6006	2,8
2"	60x5,0	FFD-606-60x5	FFD-006-60x5	O-RING-50,52X1,78	-	FF-6006	2,5
2"	60x6,0	FFD-606-60x6	FFD-006-60x6	O-RING-47,35X1,78	-	FF-6006	2,5
2"	60,3X3,91	FFD-606-60,3x3,91	FFD-006-60,3x3,91	O-RING-50,52X1,78	-	FF-6006	2,8
2"	60,3X5,54	FFD-606x60,3x5,54	FFD-006x60,3x5,54	O-RING-47,35X1,78	-	FF-6006	2,8

*1 oder vergleichbare Güte / or comparable material

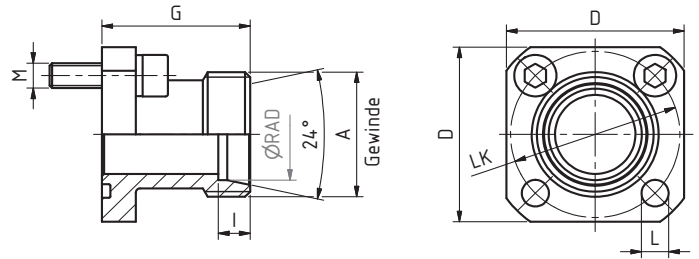

Bestellbezeichnung: ordering code:	C 45
<ul style="list-style-type: none"> • Flansch incl. metrischem Schraubensatz u. O-Ring <i>flange including metric bolts and o-ring</i> 	GF-...K
<ul style="list-style-type: none"> • Flansch incl. metrischem Schraubensatz, O-Ring, Schneidring und Mutter <i>flange including metric bolts, o-ring, cutting ring and nut</i> 	GF-...KM

maximaler Betriebsdruck <i>maximum recommended working pressure</i>	Lochkreis <i>hole-figuration</i>	Typ <i>type</i>	Abmessungen <i>dimensions</i>						Schrauben <i>bolts</i>	O-Ring <i>o-ring</i>	Gewicht (nur Flansch) <i>weight (flange only)</i>
			RAD	A	D	G	I	L			
315	35	GF 35LK-L10	L 10	M 16x1,5	39	30	7,0	6,4	4 x M6 x 22	20 x 2,5	0,09
315	35	GF 35LK-L12	L 12	M 18x1,5	39	30	7,0	6,4	4 x M6 x 22	20 x 2,5	0,09
250	35	GF 35LK-L15	L 15	M 22x1,5	39	30	7,0	6,4	4 x M6 x 22	20 x 2,5	0,10
250	35	GF 35LK-L18	L 18	M 26x1,5	39	30	7,5	6,4	4 x M6 x 22	20 x 2,5	0,12
315	35	GF 35LK-S16	S 16	M 24x1,5	39	30	8,5	6,4	4 x M6 x 22	20 x 2,5	0,11
100	40	GF 40LK-L15	L 15	M 22x1,5	42	35	7,0	6,4	4 x M6 x 22	26 x 2,5	0,12
100	40	GF 40LK-L18	L 18	M 26x1,5	42	35	7,5	6,4	4 x M6 x 22	26 x 2,5	0,12
100	40	GF 40LK-L22	L 22	M 30x2	42	35	7,5	6,4	4 x M6 x 22	26 x 2,5	0,13
100	40	GF 40LK-L28	L 28	M 36x2	42	42	7,5	6,4	4 x M6 x 22	26 x 2,5	0,16
100	55	GF 55LK-L28	L 28	M 36x2	55	40	7,5	8,4	4 x M8 x 25	32 x 2,5	0,31
100	55	GF 55LK-L35	L 35	M 45x2	55	50	10,5	8,4	4 x M8 x 25	32 x 2,5	0,35
100	55	GF 55LK-L42	L 42	M 52x2	55	55	11	8,4	4 x M8 x 25	32 x 2,5	0,42
250	55	GF 55LK-S20	S 20	M 30x2	55	40	10,5	8,4	4 x M8 x 25	32 x 2,5	0,30

Oberfläche: CR-6: auslaufend/Neu: CR-6 frei / surface: CR-6: phase-out/New: CR-6 free

*1 oder vergleichbare Güte / or comparable material

165 | Flanschverschraubung 90° – 24° DIN 3901

Flange connection 90° – 24° DIN 3901

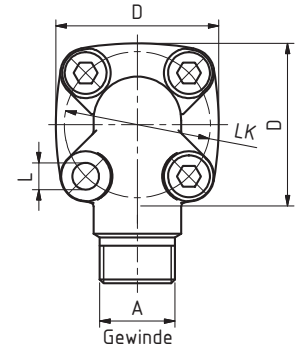
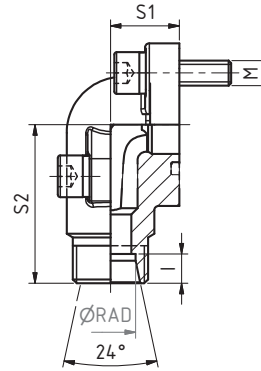

Bestellbezeichnung: ordering code:	ZG230-450 C 45
<ul style="list-style-type: none"> • Flansch incl. metrischem Schraubensatz u. O-Ring flange including metric bolts and o-ring • Flansch incl. metrischem Schraubensatz, O-Ring, Schneidring und Mutter flange including metric bolts, o-ring, cutting ring and nut 	WF-...K WF-...KM

maximaler Betriebsdruck maximum recommended working pressure	Lochkreis hole-figuration	Typ type	Abmessungen dimensions							Schrauben bolts	O-Ring o-ring	Gewicht (nur Flansch) weight (flange only)
			RAD	A	D	S1	S2	I	L			
315	35	WF 35LK-L10	L 10	M 16x1,5	39	16,5	38,0	7,0	6,4	2 x M6 x 22 2 x M6 x 35	20 x 2,5	0,12
315	35	WF 35LK-L12	L 12	M 18x1,5	39	16,5	38,0	7,0	6,4	2 x M6 x 22 2 x M6 x 35	20 x 2,5	0,13
250	35	WF 35LK-L15	L 15	M 22x1,5	39	16,5	38,0	7,0	6,4	2 x M6 x 22 2 x M6 x 35	20 x 2,5	0,14
250	35	WF 35LK-L15-F	L 15	M 22x1,5	39	16,5	38,0	7,0	6,4	2 x M6 x 22 2 x M6 x 40	20 x 2,5	0,14
250	35	WF 35LK-L18	L 18	M 26x1,5	39	20,0	38,0	7,5	6,4	2 x M6 x 22 2 x M6 x 40	20 x 2,5	0,22
315	35	WF 35LK-S12	S 12	M 20x1,5	39	16,5	38,0	7,5	6,4	2 x M6 x 22 2 x M6 x 35	20 x 2,5	0,16
315	35	WF 35LK-S16	S 16	M 24x1,5	39	20,0	38,0	8,5	6,4	2 x M6 x 22 2 x M6 x 40	20 x 2,5	0,17
315	35	WF 35LK-S20	S 20	M 30x2	39	25,0	45,0	10,5	6,4	2 x M6 x 22 2 x M6 x 45	20 x 2,5	0,27
100	40	WF 40LK-L15	L 15	M 22x1,5	42	22,5	38,0	7,0	6,4	4 x M6 x 22	26 x 2,5	0,15
100	40	WF 40LK-L15-F	L 15	M 22x1,5	42	22,5	38,0	7,0	6,4	2 x M6 x 22 2 x M6 x 45	26 x 2,5	0,15
100	40	WF 40LK-L18	L 18	M 26x1,5	42	22,5	38,0	7,5	6,4	4 x M6 x 22	26 x 2,5	0,17
100	40	WF 40LK-L18-F	L 18	M 26x1,5	42	22,5	38,0	7,5	6,4	2 x M6 x 22 2 x M6 x 45	26 x 2,5	0,17
100	40	WF 40LK-L22	L 22	M 30x2	42	22,5	38,0	7,5	6,4	4 x M6 x 22	26 x 2,5	0,19
100	40	WF 40LK-L28	L 28	M 36x2	42	28,0	40,0	7,5	6,4	2 x M6 x 22 2 x M6 x 50	26 x 2,5	0,27
100	40	WF 40LK-L35	L 35	M 45x2	42	34,0	41,0	10,5	6,4	2 x M6 x 22 2 x M6 x 60	26 x 2,5	0,35
250	40	WF 40LK-S20	S 20	M 30x2	42	22,5	40,0	10,5	6,4	2 x M6 x 22 2 x M6 x 45	26 x 2,5	0,20
100	55	WF 55LK-L22	L 22	M 30x2	58	24	45	7,5	8,4	2 x M8 x 25 2 x M8 x 50	32 x 2,5	0,45
100	55	WF 55LK-L35	L 35	M 45x2	58	32,0	49,0	10,5	8,4	2 x M8 x 25 2 x M8 x 60	32 x 2,5	0,46
100	55	WF 55LK-L42	L 42	M 52x2	58	40,0	49,0	11,0	8,4	2 x M8 x 25 2 x M8 x 70	32 x 2,5	0,61
250	55	WF 55LK-S20	S 20	M 30x2	58	24,0	45,0	10,5	8,4	2 x M8 x 25 2 x M8 x 50	32 x 2,5	0,43
250	55	WF 55LK-S25	S 25	M 36x2	58	30,0	49,0	12,0	8,4	2 x M8 x 25 2 x M8 x 55	32 x 2,5	0,49
250	55	WF 55LK-S30	S 30	M 42x2	58	32,0	49,0	13,5	8,4	2 x M8 x 25 2 x M8 x 50	32 x 2,5	0,51

Oberfläche: CR-6: auslaufend/Neu: CR-6 frei / surface: CR-6: phase-out/New: CR-6 free

*1 oder vergleichbare Güte / or comparable material

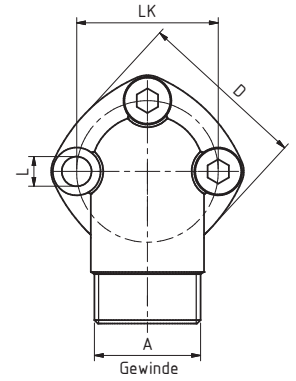
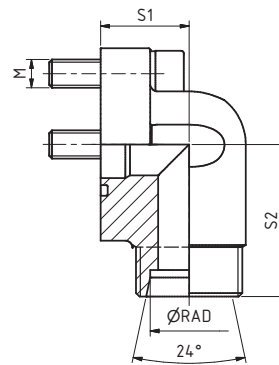

Bestellbezeichnung: ordering code:	C 45^{*1}
<ul style="list-style-type: none"> • Flansch incl. metrischem Schraubensatz u. O-Ring <i>flange including metric bolts and o-ring</i> 	WF-...K
<ul style="list-style-type: none"> • Flansch incl. metrischem Schraubensatz, O-Ring, Schneidring und Mutter <i>flange including metric bolts, o-ring, cutting ring and nut</i> 	WF-...KM

maximaler Betriebsdruck <i>maximum recommended working pressure</i>	Lochkreis <i>hole-figuration</i>	Typ <i>type</i>	Abmessungen <i>dimensions</i>								Schrauben <i>bolts</i>	O-Ring <i>o-ring</i>	Gewicht (nur Flansch) <i>weight (flange only)</i>
			RAD	A	D	S1	S2	I	L	M			
250	30	WF 30LK-L12/3	L 12	M 18x1,5	38	19	37,0	7,0	6,4	3 x M6 x 25	16 x 2,5	0,13	
250	30	WF 30LK-L15/3	L 15	M 22x1,5	38	19	37,0	7,0	6,4	3 x M6 x 25	16 x 2,5	0,14	
160	40	WF 40LK-L22/3	L 22	M 30x2	48	25	43,0	7,5	8,4	3 x M8 x 30	24 x 2,5	0,29	
160	40	WF 40LK-L28/3	L 28	M 36x2	48	25	43,0	7,5	8,4	3 x M8 x 30	24 x 2,5	0,40	

Oberfläche: CR-6: auslaufend/Neu: CR-6 frei / *surface: CR-6: phase-out/New: CR-6 free*

*1 oder vergleichbare Güte / *or comparable material*

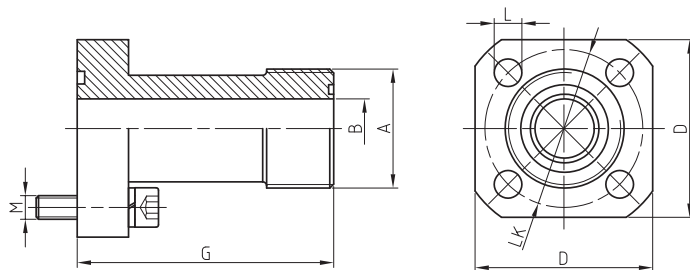

Bestellbezeichnung: ordering code:	C 45^{*1}
• nur Flansch flange only	GF-...LK-...
• Flansch incl. metrischem Schraubensatz und O-Ring flange including metric bolts and o-ring	GF-...LK-...M

maximaler Betriebsdruck maximum recommended working pressure	Lochkreis hole-figuration	Typ type	Abmessungen dimensions					Schrauben bolts	O-Ring o-ring	Gewicht (nur Flansch) weight (flange only)	
			A	B	D	G	L				M
kg/cm ²	LK										
210	210	35	GF-35LK-1 ³ / ₁₆ -16	1 ³ / ₁₆ -16UN	9,5	40	50	7	4 x M6 x 25	20 x 2,5	0,18
210	210	40	GF-40LK-1 ³ / ₁₆ -12	1 ³ / ₁₆ -12UN	15,0	45	65	7	4 x M6 x 25	24 x 2,5	0,33
210	210	40	GF-40LK-1 ⁷ / ₁₆ -12	1 ⁷ / ₁₆ -12UN	20,6/16,0	45	65	7	4 x M6 x 25	26 x 2,5	0,36

Oberfläche: CR-6: auslaufend/Neu: CR-6 frei / surface: CR-6: phase-out/New: CR-6 free

*1 oder vergleichbare Güte / or comparable material

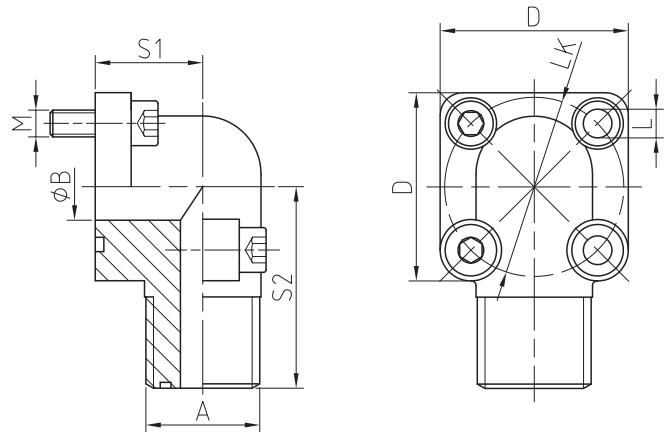

Bestellbezeichnung: ordering code:	EN-GJMW-400-5*1
<ul style="list-style-type: none"> nur Winkelflanschverschraubung flange only Winkelflanschverschraubung incl. metrischem Schraubensatz und O-Ring flange including metric bolts and o-ring 	WF-...LK-UN... WF-...LK-UN...M

maximaler Betriebsdruck maximum recommended working pressure		Lochkreis hole-figuration	Typ type	Abmessungen dimensions						Schrauben bolts	O-Ring o-ring	Gewicht (nur Flansch) weight (flange only)
kg/cm ²	LK			A	B	D	S1	S2	L			
210	210	30	WF-30LK-1 ¹ / ₁₆	1 ¹ / ₁₆ UN	6,5	30	15	30	5,4	2 x M5 x 20 2 x M5 x 25	15 x 2,5	0,12
210	210	30	WF 30LK-1 ³ / ₁₆	1 ³ / ₁₆ UN	9,5	30	15	30	6,4	2 x M6 x 20 2 x M6 x 30	15 x 2,5	0,11
210	210	35	WF 35LK-1 ³ / ₁₆	1 ³ / ₁₆ UN	9,5	40	20	55	6,4	2 x M6 x 20 2 x M6 x 30	18 x 2,5	0,25
210	210	40	WF 40LK-1	1UN	15,0	45	24	60	6,4	2 x M6 x 20 2 x M6 x 40	24 x 2,5	0,59
210	210	40	WF 40LK-1 ⁷ / ₁₆	1 ⁷ / ₁₆ UN	20,0	42	28	40	6,4	2 x M6 x 20 2 x M6 x 50	26 x 2,5	0,26
210	210	55	WF 55LK-1 ¹ / ₁₆	1 ¹ / ₁₆ UN	26,0	58	32	49	8,4	2 x M8 x 22 2 x M8 x 50	32 x 2,5	0,57

Oberfläche: CR-6: auslaufend/Neu: CR-6 frei / surface: CR-6: phase-out/New: CR-6 free

*1 oder vergleichbare Güte / or comparable material

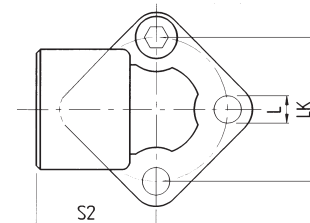
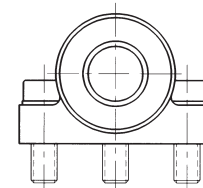
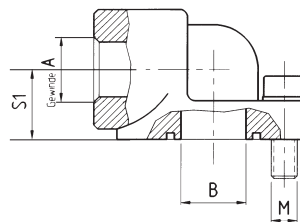

Bestellbezeichnung: ordering code:	C 45^{*1}
• Flansch incl. metrischem Schraubensatz u. O-Ring flange including metric bolts and o-ring	WDS-...K

maximaler Betriebsdruck maximum recommended working pressure kg/cm ²	Lochkreis hole-figuration LK	Typ type	Abmessungen dimensions					Schrauben bolts M	O-Ring o-ring	Gewicht (nur Flansch) weight (flange only) kg
			A	B	S1	S2	L			
315	26	WDS 05/38	G 3/8"	11	17	24	5,3	3 x M5 x 20	14 x 1,78	0,16
315	26	WDS 05/12	G 1/2"	11	17	24	5,3	3 x M5 x 20	14 x 1,78	0,15
315	30	WDS 1/38	G 3/8"	12	17	26	6,3	3 x M6 x 20	15,88 x 2,62	0,16
315	30	WDS 1/12	G 1/2"	12	17	26	6,3	3 x M6 x 20	15,88 x 2,62	0,15
315	40	WDS 2/12	G 1/2"	19	21	36	8,5	3 x M8 x 25	23,81 x 2,62	0,33
315	40	WDS 2/34	G 3/4"	19	21	36	8,5	3 x M8 x 25	23,81 x 2,62	0,31
315	51	WDS 3/34	G 3/4"	26	26	45	10,5	3 x M10 x 30	31,42 x 2,62	0,57
315	51	WDS 3/100	G 1"	24	26	45	10,5	3 x M10 x 30	31,42 x 2,62	0,52
315	56	WDS 3B/34	G 3/4"	26	26	45	10,5	3 x M10 x 30	31,42 x 2,62	0,57
315	56	WDS 3B/100	G 1"	26	26	45	10,5	3 x M10 x 30	31,42 x 2,62	0,52

Oberfläche: CR-6: auslaufend/Neu: CR-6 frei / surface: CR-6: phase-out/New: CR-6 free

*1 oder vergleichbare Güte / or comparable material

170 | 4-Loch Flansch 90° BSPP-Gewinde Stahl

4-hole flange 90° BSPP-threaded steel

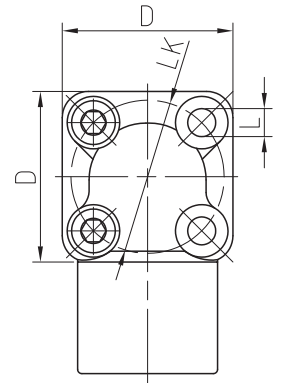
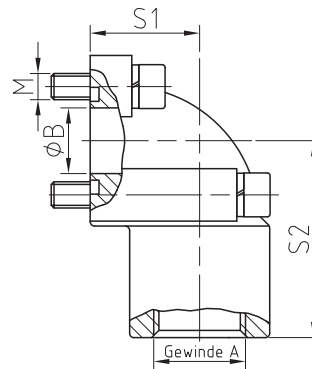

Bestellbezeichnung: ordering code:	C 45^{*1} / ZG230-450
• Winkelflanschverschraubung incl. metrischem Schraubensatz und O-Ring flange including metric bolts and o-ring	WF-...LK-G...M

maximaler Betriebsdruck maximum recommended working pressure	Lochkreis hole-figuration	Typ type	Abmessungen dimensions						Schrauben bolts	O-Ring o-ring	Gewicht (nur Flansch) weight (flange only)
			A	B	D	S1	S2	L			
kg/cm ²	LK								M		kg
315	35	WF-35LK-G012	G 1/2"	15	39	25	45,0	6,4	2 x M6 x 22 2 x M6 x 45	20 x 2,5	0,25
315	35	WF 35LK-G038-F	G 3/8"	14	39	18	40,0	6,4	2 x M6 x 22 2 x M6 x 40	20 x 2,5	0,27
250	40	WF 40LK-G012	G 1/2"	20	42	28	50,0	6,4	2 x M6 x 22 2 x M6 x 50	26 x 2,5	0,41
160	40	WF 40LK-G034-F	G 3/4"	20	42	24	42,5	6,4	2 x M6 x 25 2 x M6 x 45	26 x 2,5	0,33
160	40	WF 40LK-G100	G 1"	20	42	34	51,0	6,4	2 x M6 x 22 2 x M6 x 60	26 x 2,5	0,47
160	55	WF 55LK-G100	G 1"	20	58	40	59,0	8,4	2 x M8 x 25 2 x M8 x 70	32 x 2,5	0,87
160	55	WF 55LK-G114	G 1 1/4"	26	58	40	59,0	8,4	2 x M8 x 25 2 x M8 x 70	32 x 2,5	0,73

Oberfläche: CR-6: auslaufend/Neu: CR-6 frei / surface: CR-6: phase-out/New: CR-6 free

*1 oder vergleichbare Güte / or comparable material

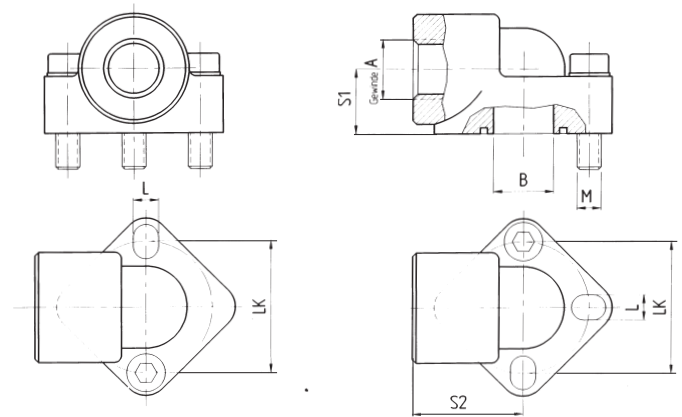

Bestellbezeichnung: ordering code:	Aluminium
• Flansch incl. metrischem Schraubensatz u. O-Ring flange including metric bolts and o-ring	WDA-...K

maximaler Betriebsdruck maximum recommended working pressure	Lochkreis hole-figuration	Typ type	Abmessungen dimensions					Schrauben bolts	O-Ring o-ring	Gewicht (nur Flansch) weight (flange only)
			A	B	S ₁	S ₂	L			
180	26,0	WDA 05/38	G 3/8"	10,0	18,0	31	5,3	3 x M5 x 35	14 x 1,78	0,06
180	26,0	WDA 05/12	G 1/2"	10,0	18,0	31	5,3	3 x M5 x 35	14 x 1,78	0,05
180	30,0	WDA 1/38	G 3/8"	12,5	18,0	30	6,5	3 x M6 x 35	15,88 x 2,62	0,08
180	30,0	WDA 1/12	G 1/2"	12,5	18,0	30	6,5	3 x M6 x 35	15,88 x 2,62	0,08
180	40,0	WDA 2/12	G 1/2"	18,5	20,0	40	8,5	3 x M8 x 45	22,22 x 2,62	0,15
180	40,0	WDA 2/34	G 3/4"	18,5	20,0	40	8,5	3 x M8 x 45	22,22 x 2,62	0,16
180	51,0 - 56,0	WDA 3/34	G 3/4"	25,0	26,0	46	10,5	3 x M10 x 60	29,75 x 3,53	0,32
180	51,0 - 56,0	WDA 3/100	G 1"	25,0	26,0	46	10,5	3 x M10 x 60	29,75 x 3,53	0,33
120	62,0	WDA 3,5/114 ^{*1}	G 1 1/4"	32,0	33,5	57	13,0	2 x M12 x 35	35,80 x 3,53	0,39
120	72,5	WDA 4/112 ^{*1}	G 1 1/2"	40,0	38,0	64	13,0	2 x M12 x 35	44,04 x 3,53	0,49

*1 Ausführung: 2 Lochflansch / Type: 2-hole flange

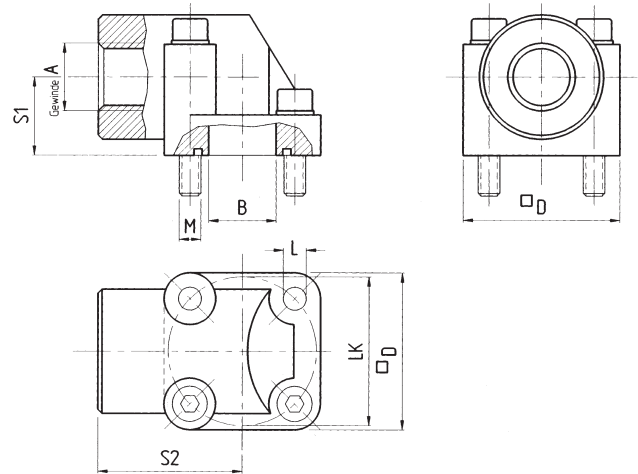

Bestellbezeichnung: ordering code:	Aluminium
• Flansch incl. metrischem Schraubensatz u. O-Ring flange including metric bolts and o-ring	WVA-...K

maximaler Betriebsdruck maximum recommended working pressure	Lochkreis hole-figuration	Typ type	Abmessungen dimensions						Schrauben bolts	O-Ring o-ring	Gewicht (nur Flansch) weight (flange only)
			A	B	D	S1	S2	L			
180	30	WVA 38/30	G 3/8"	11,5	35,0	18	40,0	6,5	2 x M6 x 30 2 x M6 x 45	15,88 x 2,62	0,09
180	30	WVA 12/30	G 1/2"	11,5	35,0	18	40,0	6,5	2 x M6 x 30 2 x M6 x 45	15,88 x 2,62	0,09
180	35	WVA 38/35	G 3/8"	14,0	38,5	18	42,5	6,5	2 x M6 x 30 2 x M6 x 45	18,72 x 2,62	0,11
180	35	WVA 12/35	G 1/2"	14,0	38,5	18	42,5	6,5	2 x M6 x 30 2 x M6 x 45	18,72 x 2,62	0,10
180	40	WVA 12/40	G 1/2"	17,0	42,0	24	47,5	6,5	2 x M6 x 35 2 x M6 x 55	22,22 x 2,62	0,18
180	40	WVA 34/40	G 3/4"	17,0	42,0	24	47,5	6,5	2 x M6 x 35 2 x M6 x 55	22,22 x 2,62	0,17
180	55	WVA 34/55	G 3/4"	25,0	58,0	29	54,0	8,5	2 x M8 x 45 2 x M8 x 60	29,75 x 3,53	0,31
120	55	WVA 100/55	G 1"	25,0	58,0	29	54,0	8,5	2 x M8 x 45 2 x M8 x 60	29,75 x 3,53	0,30

173 | 4-Loch Einschweißflansch 90°

4-hole socket weld flange 90°

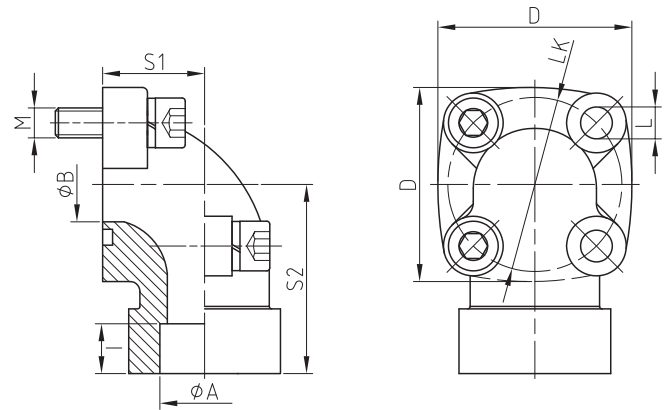

Bestellbezeichnung: ordering code:	EN-GJMW-400-5^{*1}
<ul style="list-style-type: none"> • nur Winkelflanschverschraubung flange only • Winkelflanschverschraubung incl. metrischem Schraubensatz und O-Ring flange including metric bolts and o-ring 	<p>WF-...LK-E...</p> <p>WF-...LK-E...M</p>

maximaler Betriebsdruck maximum recommended working pressure	Lochkreis hole-figuration	Typ type	Abmessungen dimensions							Schrauben bolts	O-Ring o-ring	Gewicht (nur Flansch) weight (flange only)
			A	B	D	I	S1	S2	L			
315	35	WF-35LK-L10E	10,1	14	39	10,0	16,5	38	6,4	2 x M6 x 22 2 x M6 x 35	20 x 2,5	0,15
315	35	WF 35LK-L12E	12,1	14	39	10,0	16,5	38	6,4	2 x M6 x 22 2 x M6 x 35	20 x 2,5	0,15
250	35	WF 35LK-L15E	15,1	14	39	10,0	16,5	38	6,4	2 x M6 x 22 2 x M6 x 35	20 x 2,5	0,16
250	35	WF 35LK-L18E	18,1	15	39	10,0	20,5	38	6,4	2 x M6 x 22 2 x M6 x 40	20 x 2,5	0,20
315	35	WF 35LK-S16E	16,1	15	39	10,0	20,5	38	6,4	2 x M6 x 22 2 x M6 x 40	20 x 2,5	0,18
315	35	WF 35LK-S20E	20,1	15	39	10,0	25,5	45	6,4	2 x M6 x 25 2 x M6 x 45	20 x 2,5	0,25
100	40	WF 40LK-L15E	15,1	20	42	10,0	23,0	38	6,4	4 x M6 x 22	26 x 2,5	0,24
100	40	WF 40LK-L18E	18,1	20	42	10,0	23,0	38	6,4	4 x M6 x 22	26 x 2,5	0,23
100	40	WF 40LK-L22E	22,1	20	42	10,0	23,0	38	6,4	4 x M6 x 22	26 x 2,5	0,21
100	40	WF 40LK-L28E	28,1	20	42	14,4	28,0	40	6,4	2 x M6 x 22 2 x M6 x 50	26 x 2,5	0,27
100	40	WF 40LK-L35E	35,1	20	42	10,0	34,0	41	6,4	2 x M6 x 22 2 x M6 x 60	26 x 2,5	0,29
100	55	WF 55LK-L35E	35,1	26	58	10,0	31,0	49	8,4	2 x M8 x 25 2 x M8 x 60	32 x 2,5	0,51
100	55	WF 55LK-L42E	42,1	26	58	10,0	40,0	49	8,4	2 x M8 x 25 2 x M8 x 70	32 x 2,5	0,64
250	55	WF 55LK-S20E	20,1	18	58	10,0	24,0	45	8,4	2 x M8 x 25 2 x M8 x 50	32 x 2,5	0,46
250	55	WF 55LK-S25E	25,1	20	58	10,0	30,0	49	8,4	2 x M8 x 25 2 x M8 x 55	32 x 2,5	0,52
250	55	WF 55LK-S30E	30,1	26	58	10,0	32,0	49	8,4	2 x M8 x 25 2 x M8 x 50	32 x 2,5	0,53

*1 oder vergleichbare Güte / or comparable material

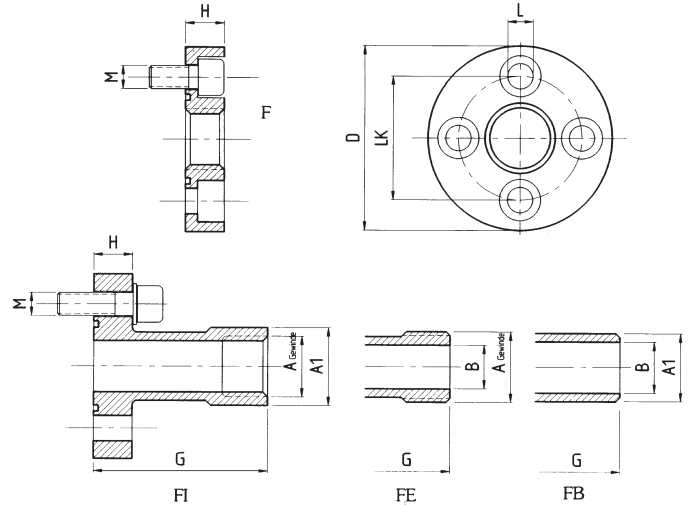

Bestellbezeichnung: ordering code:	C 45^{*1}
• Flansch incl. Schraubensatz und O-Ring flange including bolts and o-ring	F-...K

maximaler Betriebsdruck maximum recommended working pressure kg/cm ²	Lochkreis hole-figuration LK	Typ type	Abmessungen dimensions							Schrauben bolts M	O-Ring o-ring	Gewicht (nur Flansch) weight (flange only) kg
			A	A ₁	B	D	G	H	L			
250	30,0	F 1-H15	G 3/8"	-	-	45	-	15,0	6,5	4 x M6 x 16	18,77 x 1,78	0,13
250	30,0	FI 1	G 3/8"	21,0	-	45	55	10,0	6,5	4 x M6 x 20	18,77 x 1,78	0,15
250	30,0	FE 1	G 1/2"	-	14,0	45	55	10,0	6,5	4 x M6 x 20	18,77 x 1,78	0,15
250	30,0	FB 1	-	19,0	14,0	45	55	10,0	6,5	4 x M6 x 20	18,77 x 1,78	0,15
250	40,0	F 2-H18	G 1/2"	-	-	58	-	18,0	8,5	4 x M8 x 20	25,12 x 1,78	0,27
250	40,0	FI 2	G 1/2"	26,5	-	58	60	12,0	8,5	4 x M8 x 25	25,12 x 1,78	0,27
250	40,0	FE 2	G 3/4"	-	19,0	58	60	12,0	8,5	4 x M8 x 25	25,12 x 1,78	0,27
250	40,0	FB 2	-	25,4	19,0	58	60	12,0	8,5	4 x M8 x 25	25,12 x 1,78	0,27
250	51,0	F 3A	G 3/4"	-	-	76	-	18,0	10,5	4 x M10 x 25	31,42 x 2,62	0,48
250	51,0	FI 3A	G 3/4"	33,5	-	76	72	16,0	10,5	4 x M10 x 30	31,42 x 2,62	0,59
250	51,0	FE 3A	G 1"	-	24,0	76	72	16,0	10,5	4 x M10 x 30	31,42 x 2,62	0,59
250	51,0	FB 3A	-	32,0	24,5	76	72	16,0	10,5	4 x M10 x 30	31,42 x 2,62	0,59
250	56,0	F 3B	G 3/4"	-	-	76	-	18,0	10,5	4 x M10 x 25	31,42 x 2,62	0,48
250	56,0	FI 3B	G 3/4"	33,5	-	76	72	16,0	10,5	4 x M10 x 30	31,42 x 2,62	0,59
250	56,0	FE 3B	G 1"	-	24,0	76	72	16,0	10,5	4 x M10 x 30	31,42 x 2,62	0,69
250	56,0	FB 3B	-	32,0	24,5	76	72	16,0	10,5	4 x M10 x 30	31,42 x 2,62	0,59
180	62,0	F 3,5A	G 1"	-	-	88	-	20,0	10,5	4 x M10 x 25	39,70 x 3,53	0,53
180	62,0	F 3,5B	G 1"	-	-	88	-	20,0	12,5	4 x M12 x 25	39,70 x 3,53	0,59
180	72,5	F 4	G 1 1/4"	-	-	98	-	22,0	12,5	4 x M12 x 30	47,20 x 3,53	0,64

Oberfläche: CR-6: auslaufend/Neu: CR-6 frei / surface: CR-6: phase-out/New: CR-6 free

*1 oder vergleichbare Güte / or comparable material

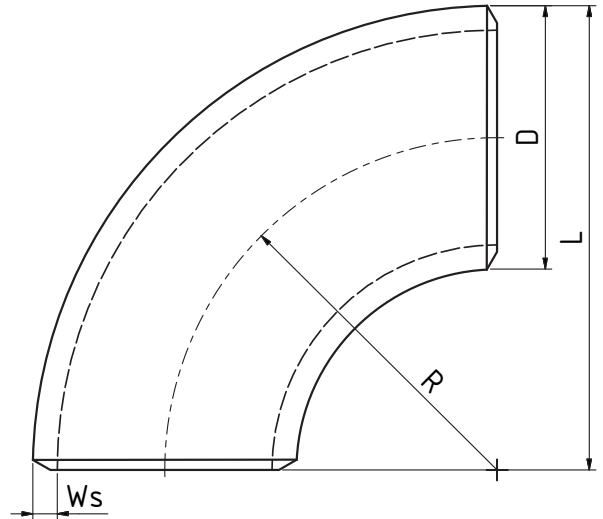

Bestellbezeichnung: ordering code:	P235GH
• Rohrbogen elbow	RB90-...

Baugröße size	DN DN	Typ type	Abmessung (Bauart 3) dimension (design 3)			
			D	Ws	R	L
1/2"	15	RB90-21,3x4,5	21,3	4,5	28	39
	Sched.40	RB90-21,3x2,8	21,3	2,8	28	39
	Sched.80	RB90-21,3x3,8	21,3	3,8	28	39
	Sched.XXS	RB90-21,3x7,47	21,3	7,47	28	39
3/4"	20	RB90-26,9x5,6	26,9	5,6	29	42,4
	Sched.40	RB90-26,7x2,9	26,7	2,9	29	42,4
	Sched.80	RB90-26,7x3,9	26,7	3,9	29	42,4
	Sched.XXS	RB90-26,7x7,82	26,7	7,82	29	42,4
1"	25	RB90-33,7x6,3	33,7	6,3	38	55
	Sched.10	RB90-33,4x2,8	33,4	2,8	38	55
	Sched.40	RB90-33,4x3,4	33,4	3,4	38	55
	Sched.80	RB90-33,4x4,6	33,4	4,6	38	55
1 1/4"	32	RB90-42,4x6,3	42,4	6,3	48	69
	Sched.10	RB90-42,2x2,8	42,2	2,8	48	69
	Sched.40	RB90-42,2x3,6	42,2	3,6	48	69
	Sched.80	RB90-42,2x4,9	42,2	4,9	48	69
1 1/2"	Sched.XXS	RB90-42,2x9,7	42,2	9,7	48	69
	40	RB90-48,3x6,3	48,3	6,3	57	81
	40	RB90-48,3x10	48,3	10	57	81
	Sched.10	RB90-48,3x2,8	48,3	2,8	57	81
1 1/2"	Sched.40	RB90-48,3x3,7	48,3	3,7	57	81
	Sched.80	RB90-48,3x5	48,3	5	57	81
	Sched.160	RB90-48,3x7,14	48,3	7,14	57	81

2"	50	RB90-60,3x5,6	60,3	5,6	76	106
	50	RB90-60,3x10	60,3	10	76	106
	Sched.10	RB90-60,3x2,9	60,3	2,9	76	106
	Sched.40	RB90-60,3x3,9	60,3	3,9	76	106
	Sched.160	RB90-60,3x8,7	60,3	8,7	76	106
2 1/2"	Sched.XXS	RB90-60,3x11,07	60,3	11,07	76	106
	65	RB90-76,1x7,1	76,1	7,1	95	133
	65	RB90-76,1x3,6	76,1	3,6	95	133
	65	RB90-76,1x10	76,1	10	95	133
	65	RB90-76,1x12,5	76,1	12,5	95	133
	Sched.10	RB90-73x3	73	3	95	131
	Sched.40	RB90-73x5,1	73	5,1	95	131
	Sched.80	RB90-73x7	73	7	95	131
	Sched.160	RB90-73x9,5	73	9,5	95	131
	3"	80	RB90-88,9x8,0	89	8	114
80		RB90-88,9x3,6	89	3,6	114	159
Sched.40		RB90-88,9x5,5	89	5,5	114	159
Sched.160		RB90-88,9x11,13	89	11,13	114	159
Sched.XXS		RB90-88,9x15,24	89	15,24	114	159
3 1/2"	90	RB90-101,6x6,3	101,6	6,3	133	184
	Sched.40	RB90-101,6x5,7	101,6	5,7	133	184
	Sched.80	RB90-101,6x8	101,6	8	133	184
4"	100	RB90-114,3x8,8	114,3	8,8	152	210
	Sched.10	RB90-114,3x3	114,3	3	152	210
	Sched.40	RB90-114,3x6	114,3	6	152	210
	Sched.160	RB90-114,3x13,5	114,3	13,5	152	210
	Sched.XXS	RB90-114,3x17,12	114,3	17,12	152	210
5"	125	RB90-139,7x10	139,7	10	190	260

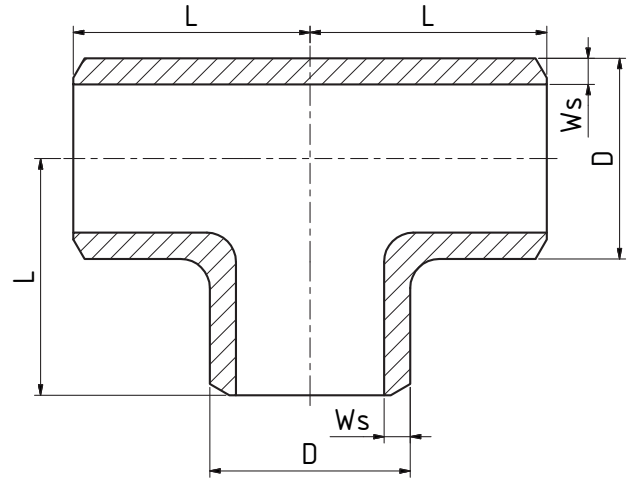

Bestellbezeichnung: P235GH	
ordering code:	
• Rohrbogen elbow	T-...

Baugröße nominal flange size	DN DN	Typ type	Abmessungen dimensions		
			D	Ws	L
1/2"	15	T-21,3x4,5	21,3	4,5	25
	Sched.40	T-21,3x2,8	21,3	2,8	25
	Sched.80	T-21,3x3,8	21,3	3,8	25
	Sched.XXS	T-21,3x7,47	21,3	7,47	25
3/4"	20	T-26,9x5,6	26,9	5,6	29
	Sched.40	T-26,7x2,9	26,7	2,9	29
	Sched.80	T-26,7x3,9	26,7	3,9	29
	Sched.XXS	T-26,7x7,82	26,7	7,82	29
1"	25	T-33,7x6,3	33,7	6,3	38
	Sched.10	T-33,4x2,8	33,4	2,8	38
	Sched.40	T-33,4x3,4	33,4	3,4	38
	Sched.80	T-33,4x4,6	33,4	4,6	38
1 1/4"	Sched.XXS	T-33,4x9,09	33,4	9,09	38
	32	T-42,4x6,3	42,4	6,3	48
	Sched.10	T-42,2x2,8	42,2	2,8	48
	Sched.40	T-42,2x3,6	42,2	3,6	48
1 1/2"	Sched.80	T-42,2x4,9	42,2	4,9	48
	Sched.XXS	T-42,2x9,7	42,2	9,7	48
	40	T-48,3x6,3	48,3	6,3	57
	40	T-48,3x10	48,3	10	57
	Sched.10	T-48,3x2,8	48,3	2,8	57
	Sched.40	T-48,3x3,7	48,3	3,7	57
2"	Sched.80	T-48,3x5	48,3	5	57
	Sched.160	T-48,3x7,14	48,3	7,14	57

2"	50	T-60,3x5,6	60,3	5,6	64
	50	T-60,3x10	60,3	10	64
	Sched.10	T-60,3x2,9	60,3	2,9	64
	Sched.40	T-60,3x3,9	60,3	3,9	64
	Sched.160	T-60,3x8,7	60,3	8,7	64
2 1/2"	Sched.XXS	T-60,3x11,07	60,3	11,07	64
	65	T-76,1x7,1	76,1	7,1	76
	65	T-76,1x3,6	76,1	3,6	76
	65	T-76,1x10	76,1	10	76
	65	T-76,1x12,5	76,1	12,5	76
	Sched.10	T-73x3	73	3	76
	Sched.40	T-73x5,1	73	5,1	76
	Sched.80	T-73,0x7,0	73	7	76
3"	Sched.160	T-73x9,5	73	9,5	76
	80	T-88,9x8,0	89	8	86
	80	T-88,9x3,6	89	3,6	86
	Sched.40	T-88,9x5,5	89	5,5	86
	Sched.160	T-88,9x11,13	89	11,13	86
3 1/2"	Sched.XXS	T-88,9x15,24	89	15,24	86
	90	T-101,6x6,3	101,6	6,3	95
	Sched.40	T-101,6x5,7	101,6	5,7	95
4"	Sched.80	T-101,6x8	101,6	8	95
	100	T-114,3x8,8	114,3	8,8	105
	Sched.10	T-114,3x3	114,3	3	105
	Sched.40	T-114,3x6	114,3	6	105
	Sched.160	T-114,3x13,5	114,3	13,5	105
	Sched.XXS	T-114,3x17,12	114,3	17,12	105
5"	125	T-139,7x10	139,7	10	124

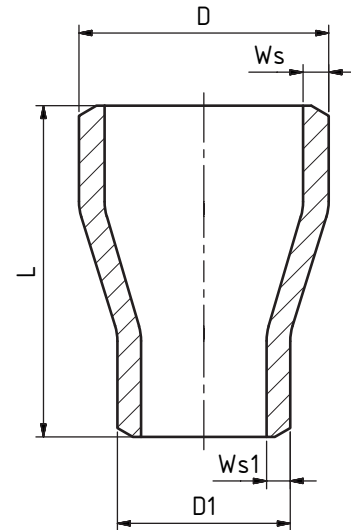
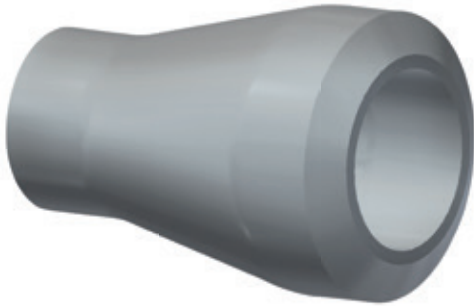

Bestellbezeichnung: ordering code:	P235GH
• Reduzierstück konzentrisch reducer	RKS-...

Baugröße nominal flange size	Typ type	Rohr tube	Abmessungen dimensions					
			D	Ws	D1	Ws1	L	
kg/cm ²								
3/4" - 1/2" DN20 - DN15	RKS-034/012-1	26,9x5,6-21,3x4,5	26,9	5,6	21,3	4,5	38	
	RKS-034/012-2	26,7x2,9-21,3x2,8	26,7	2,9	21,3	2,8	38	
	RKS-034/012-3	26,7x3,9-21,3x3,8	26,7	3,9	21,3	3,8	38	
	RKS-034/012-4	26,7x7,82-21,3x7,47	26,7	7,82	21,3	7,47	38	
1" - 3/4" DN25 - DN20	RKS-100/034-1	33,7x6,3-26,9x5,6	33,7	6,3	26,9	5,6	51	
	RKS-100/034-2	33,4x3,4-26,7x2,9	33,4	3,4	26,7	2,9	51	
	RKS-100/034-3	33,4x4,6-26,7x3,9	33,4	4,6	26,7	3,9	51	
	RKS-100/034-4	33,4x9,09-26,7x7,82	33,4	9,09	26,7	7,82	51	
1" - 1/2" DN25 - DN15	RKS-100/012-1	33,7x6,3-21,3x4,5	33,7	6,3	21,3	4,5	51	
	RKS-100/012-2	33,4x3,4-21,3x2,8	33,4	3,4	21,3	2,8	51	
	RKS-100/012-3	33,4x4,6-21,3x3,8	33,4	4,6	21,3	3,8	51	
	RKS-100/012-4	33,4x9,09-21,3x7,47	33,4	9,09	21,3	7,47	51	
1 1/4" - 1" DN32 - DN25	RKS-114/100-1	42,4x6,3-33,7x6,3	42,4	6,3	33,7	6,3	51	
	RKS-114/100-2	42,2x2,8-33,4x2,8	42,2	2,8	33,4	2,8	51	
	RKS-114/100-3	42,2x3,6-33,4x3,4	42,2	3,6	33,4	3,4	51	
	RKS-114/100-4	42,2x4,9-33,4x4,6	42,2	4,9	33,4	4,6	51	
	RKS-114/100-5	42,2x9,7-33,4x9,09	42,2	9,7	33,4	9,09	51	
1 1/4" - 3/4" DN32 - DN20	RKS-114/034-1	42,4x6,3-26,9x5,6	42,4	6,3	26,9	5,6	51	
	RKS-114/034-2	42,2x3,6-26,7x2,9	42,2	3,6	26,7	2,9	51	
	RKS-114/034-3	42,2x4,9-26,7x3,9	42,2	4,9	26,7	3,9	51	
	RKS-114/034-4	42,2x9,7-26,7x7,82	42,2	9,7	26,7	7,82	51	
1 1/2" - 1 1/4" DN40 - DN32	RKS-112/114-1	48,3x6,3-42,4x6,3	48,3	6,3	42,4	6,3	64	
	RKS-112/114-2	48,3x10-42,4x6,3	48,3	10	42,4	6,3	64	
	RKS-112/114-3	48,3x2,8-42,2x2,8	48,3	2,8	42,2	2,8	64	
	RKS-112/114-4	48,3x3,7-42,2x3,6	48,3	3,7	42,2	3,6	64	
	RKS-112/114-5	48,3x5-42,2x4,9	48,3	5	42,2	4,9	64	
1 1/2" - 1" DN40 - DN25	RKS-112/100-1	48,3x6,3-33,7x6,3	48,3	6,3	33,7	6,3	64	
	RKS-112/100-2	48,3x10-33,7x6,3	48,3	10	33,7	6,3	64	
	RKS-112/100-3	48,3x2,8-33,4x2,8	48,3	2,8	33,4	2,8	64	
	RKS-112/100-4	48,3x3,7-33,4x3,4	48,3	3,7	33,4	3,4	64	
	RKS-112/100-5	48,3x5-33,4x4,6	48,3	5	33,4	4,6	64	
	RKS-112/100-6	48,3x7,14-33,4x6,3	48,3	7,14	33,4	6,3	64	
2" - 1 1/2" DN50 - DN40	RKS-200/112-1	60,3x5,6-48,3x6,3	60,3	5,6	48,3	6,3	76	
	RKS-200/112-2	60,3x10-48,3x10	60,3	10	48,3	10	76	
	RKS-200/112-3	60,3x2,9-48,3x2,8	60,3	2,9	48,3	2,8	76	
	RKS-200/112-4	60,3x3,9-48,3x3,7	60,3	3,9	48,3	3,7	76	
	RKS-200/112-5	60,3x8,7-48,3x7,14	60,3	8,7	48,3	7,14	76	
	RKS-200/112-6	60,3x11,07-48,3x10,1	60,3	11,07	48,3	10,1	76	

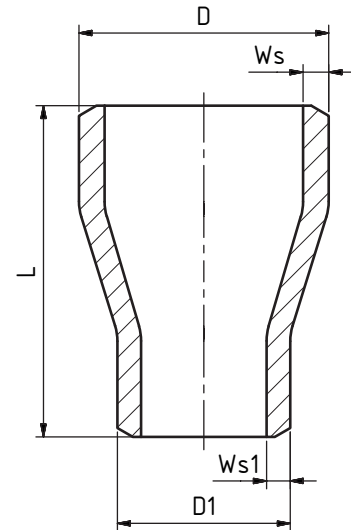
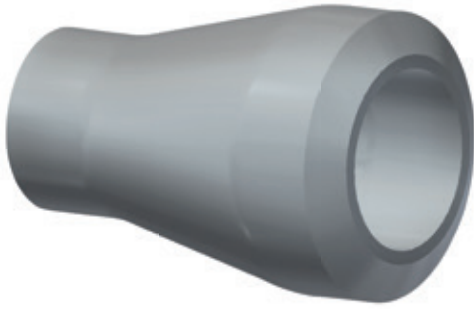

Bestellbezeichnung: ordering code:	P235GH
• Reduzierstück konzentrisch reducer	RKS-...

Baugröße nominal flange size kg/cm ²	Typ type	Rohr tube	Abmessungen dimensions				
			D	Ws	D1	Ws1	L
2" - 1 1/4" DN50 - DN32	RKS-200/114-1	60,3x5,6-42,4x6,3	60,3	5,6	42,4	6,3	76
	RKS-200/114-2	60,3x10-42,4x6,3	60,3	10	42,4	6,3	76
	RKS-200/114-3	60,3x2,9-42,2x2,8	60,3	2,9	42,4	2,8	76
	RKS-200/114-4	60,3x3,9-42,2x3,6	60,3	3,9	42,4	3,6	76
	RKS-200/114-5	60,3x8,7-42,2x6,35	60,3	8,7	42,2	6,35	76
	RKS-200/114-6	60,3x11,07-42,2x9,7	60,3	11,07	42,4	2,97	76
2 1/2" - 2" DN65 - DN50	RKS-212/200-1	76,1x7,1-60,3x5,6	76,1	7,1	60,3	5,6	89
	RKS-212/200-2	73x3-60,3x2,9	73	3	60,3	2,9	89
	RKS-212/200-3	73x5,1-60,3x3,9	73	5,1	60,3	3,9	89
	RKS-212/200-4	73x7-60,3x5,6	73	7	60,3	5,6	89
	RKS-212/200-5	73x9,5-60,3x8,7	73	9,5	60,3	8,7	89
2 1/2" - 1 1/2" DN65 - DN40	RKS-212/112-1	76,1x7,1-48,3x6,3	76,1	7,1	48,3	6,3	89
	RKS-212/112-2	73x3-48,3x2,8	73	3	48,3	2,8	89
	RKS-212/112-3	73x5,1-48,3x3,7	73	5,1	48,3	3,7	89
	RKS-212/112-4	73x7-48,3x5	73	7	48,3	5	89
	RKS-212/112-5	73x9,5-48,3x7,14	73	9,5	48,3	7,14	89
3" - 2 1/2" DN80 - DN65	RKS-300/212-1	88,9x8-76,1x7,1	88,9	8	76,1	7,1	89
	RKS-300/212-2	88,9x5,5-73x7	88,9	5,5	73	7	89
	RKS-300/212-3	88,9x11,13-73x9,5	88,9	11,13	73	9,5	89
	RKS-300/212-4	88,9x15,24-73x14,02	88,9	15,24	73	14,02	89
3" - 2" DN80 - DN50	RKS-300/200-1	88,9x8-60,3x5,6	88,9	8	60,3	5,6	89
	RKS-300/200-2	88,9x5,5-60,3x3,9	88,9	5,5	60,3	3,9	89
	RKS-300/200-3	88,9x11,13-60,3x8,7	88,9	11,13	60,3	8,7	89
	RKS-300/200-4	88,9x15,24-60,3x11,07	88,9	15,24	60,3	11,07	89
3 1/2" - 3" DN80	RKS-312/300-1	101,6x6,3-88,9x8	101,6	6,3	88,9	8	89
	RKS-312/300-2	101,6x5,7-88,9x5,5	101,6	5,7	88,9	5,5	89
	RKS-312/300-3	101,6x8-88,9x8	101,6	8	88,9	7,6	89
3 1/2" - 2 1/2" DN80 - DN65	RKS-312/212-1	101,6x6,3-76,1x7,1	101,6	6,3	76,1	7,1	89
	RKS-312/212-2	101,6x5,7-73x5,1	101,6	5,7	73	5,1	89
	RKS-312/212-3	101,6x8-73x7	101,6	8	73	7	89
4" - 3 1/2" DN100 - DN80	RKS-400/312-1	114,3x8,8-101,6x8	114,3	8,8	101,6	8	102
	RKS-400/312-2	114,3x6-101,6x5,7	114,3	6	101,6	5,7	102
4" - 3" DN100 - DN80	RKS-400/300-1	114,3x8,8-88,9x8	114,3	8,8	88,9	8	102
	RKS-400/300-2	114,3x6-88,9x5,5	114,3	6	88,9	5,5	102
	RKS-400/300-3	114,3x13,5-88,9x11,13	114,3	13,5	88,9	11,13	102
	RKS-400/300-4	114,3x17,12-88,9x15,24	114,3	17,12	88,9	15,24	102
5" - 4" DN125 - DN100	RKS-500/400-1	139,7x10-114,3x8,8	139,7	10	114,3	8,8	127
5" - 3 1/2" DN125 - DN80	RKS-500/312-1	139,7x10-101,6x6,3	139,7	10	101,6	6,3	127



BUSSE-HYDRAULIK GMBH
Weusterstraße 1, D-46240 Bottrop
Tel.: +49 2041 4664 · Fax: + 49 2041 48624
E-Mail: info@busse-hydraulik.de